

IEEE Recommended Practice for Determining the Electric Power Station Ground Potential Rise and Induced Voltage From a Power Fault

Co-Sponsors

**Power Systems Communications Committee
of the
IEEE Power Engineering Society**

and the

**Transmission and Access Systems Committee
of the
IEEE Communications Society**

Approved 16 September 1996

IEEE Standards Board

Approved 6 February 1997

American National Standards Institute

Abstract: Guidance for the calculation of power station ground potential rise (GPR) and longitudinal induction (LI) voltages is provided, as well as guidance for their appropriate reduction from worst-case values, for use in metallic telecommunication protection design.

Keywords: electric power stations, ground potential rise, induced voltage, longitudinal induction voltages, power faults, power stations, telecommunication protection design, telecommunications

The Institute of Electrical and Electronics Engineers, Inc.
345 East 47th Street, New York, NY 10017-2394, USA

Copyright © 1997 by the Institute of Electrical and Electronics Engineers, Inc.
All rights reserved. Published 1997. Printed in the United States of America.

ISBN 1-55937-886-7

No part of this publication may be reproduced in any form, in an electronic retrieval system or otherwise, without the prior written permission of the publisher.

IEEE Standards documents are developed within the IEEE Societies and the Standards Coordinating Committees of the IEEE Standards Board. Members of the committees serve voluntarily and without compensation. They are not necessarily members of the Institute. The standards developed within IEEE represent a consensus of the broad expertise on the subject within the Institute as well as those activities outside of IEEE that have expressed an interest in participating in the development of the standard.

Use of an IEEE Standard is wholly voluntary. The existence of an IEEE Standard does not imply that there are no other ways to produce, test, measure, purchase, market, or provide other goods and services related to the scope of the IEEE Standard. Furthermore, the viewpoint expressed at the time a standard is approved and issued is subject to change brought about through developments in the state of the art and comments received from users of the standard. Every IEEE Standard is subjected to review at least every five years for revision or reaffirmation. When a document is more than five years old and has not been reaffirmed, it is reasonable to conclude that its contents, although still of some value, do not wholly reflect the present state of the art. Users are cautioned to check to determine that they have the latest edition of any IEEE Standard.

Comments for revision of IEEE Standards are welcome from any interested party, regardless of membership affiliation with IEEE. Suggestions for changes in documents should be in the form of a proposed change of text, together with appropriate supporting comments.

Interpretations: Occasionally questions may arise regarding the meaning of portions of standards as they relate to specific applications. When the need for interpretations is brought to the attention of IEEE, the Institute will initiate action to prepare appropriate responses. Since IEEE Standards represent a consensus of all concerned interests, it is important to ensure that any interpretation has also received the concurrence of a balance of interests. For this reason, IEEE and the members of its societies and Standards Coordinating Committees are not able to provide an instant response to interpretation requests except in those cases where the matter has previously received formal consideration.

Comments on standards and requests for interpretations should be addressed to:

Secretary, IEEE Standards Board
445 Hoes Lane
P.O. Box 1331
Piscataway, NJ 08855-1331
USA

Note: Attention is called to the possibility that implementation of this standard may require use of subject matter covered by patent rights. By publication of this standard, no position is taken with respect to the existence or validity of any patent rights in connection therewith. The IEEE shall not be responsible for identifying patents for which a license may be required by an IEEE standard or for conducting inquiries into the legal validity or scope of those patents that are brought to its attention.

Authorization to photocopy portions of any individual standard for internal or personal use is granted by the Institute of Electrical and Electronics Engineers, Inc., provided that the appropriate fee is paid to Copyright Clearance Center. To arrange for payment of licensing fee, please contact Copyright Clearance Center, Customer Service, 222 Rosewood Drive, Danvers, MA 01923 USA; (508) 750-8400. Permission to photocopy portions of any individual standard for educational classroom use can also be obtained through the Copyright Clearance Center.

Introduction

(This introduction is not a part of IEEE Std 367-1996, IEEE Recommended Practice for Determining the Electric Power Station Ground Potential Rise and Induced Voltage From a Power Fault.)

Wire-line telecommunication facilities serving electric power stations often require that extraordinary protection measures be taken to protect against the effects of fault-produced ground potential rise (GPR) or induced voltages, or both. In the presence of a hostile electromagnetic environment, suitably rated protection equipment is required at the power station for personnel safety, for the protection of the serving telecommunication facilities, and to help ensure the desired continuity of telecommunication transmission at times of power system faults. There is a fundamental need, therefore, to determine the appropriate values of fault-produced GPR and induction, including considerations of their probability and duration, to be used in developing the specifications and ratings for the protection equipment to be used in any given application.

This recommended practice provides information for the determination of the appropriate values of fault-produced power station GPR and induction for use in the design of protection systems. Included are

- 1) The determination of the appropriate value of fault current to be used in the GPR calculation
- 2) The consideration of the waveform, probability, and duration of the fault current
- 3) The determination of inducing currents, the mutual impedance between power and telephone facilities, and shield factors
- 4) The vectorial summation of GPR and induction
- 5) The considerations regarding the power station GPR zone of influence
- 6) The communications channel time requirements for noninterruptible services

The following is a list of participants in the Joint High Voltage Interface effort of the IEEE Project 367 Working Group:

Leo J. Perfecky, *Co-Chair*

Harvey E. Nerhood, *Co-Chair*

David L. Boneau, *Secretary*

Gordon Allen
Ernest M. Duckworth, Jr.
Charles D. Hansell
David P. Hartmann
Wes M. Haynes, Jr.
Harold C. Held
Douglas Huber
Daniel C. Jendek

William J. McCoy
Charles R. Nelson
Richard E. Nelson
John H. Ng
Stanley D. Overby
Percy E. Pool
Keith Sabine
J. L. Schnegg

William Silva
Ian A. Stewart
John M. Thorson, Jr.
Matthew S. Tibensky
George Van Ginhoven
Larry S. Young

The following persons were on the balloting committee:

| | | |
|--------------------------|--------------------|----------------------|
| Gordon Allen | Richard G. Irvine | Leo J. Perfecky |
| David L. Boneau | Daniel C. Jendek | Percy E. Pool |
| Robert E. Bratton | John F. Laidig | Roger E. Ray |
| R. K. Brown | Wade P. Malcolm | Keith Sabine |
| Frances M. Cleveland | Donald J. Marihart | J. L. Schnegg |
| S. S. Dev Walia | William J. McCoy | William Silva |
| Ernest M. Duckworth, Jr. | Charles R. Nelson | Ian A. Stewart |
| Charles D. Hansell | Richard E. Nelson | Roger K. Sullivan |
| Pete R. Hanson | Harvey E. Nerhood | John M. Thorson, Jr. |
| David P. Hartmann | John H. Ng | Matthew S. Tibensky |
| Wes M. Haynes, Jr. | Gary L. Nissen | George Van Ginhoven |
| Harold C. Held | Stanley D. Overby | Robert Whapham |
| Douglas Huber | Bill Panesar | Larry S. Young |

When the IEEE Standards Board approved this standard on 19 September 1996, it had the following membership:

Donald C. Loughry, *Chair*

Richard J. Holleman, *Vice Chair*

Andrew G. Salem, *Secretary*

| | | |
|------------------------|-----------------------|-------------------|
| Gilles A. Baril | E. G. "Al" Kiener | Jose R. Ramos |
| Clyde R. Camp | Joseph L. Koepfinger* | Arthur K. Reilly |
| Joseph A. Cannatelli | Stephen R. Lambert | Ronald H. Reimer |
| Stephen L. Diamond | Lawrence V. McCall | Gary S. Robinson |
| Harold E. Epstein | L. Bruce McClung | Ingo Rüsçh |
| Donald C. Fleckenstein | Marco W. Migliaro | John S. Ryan |
| Jay Forster* | Mary Lou Padgett | Chee Kiow Tan |
| Donald N. Heirman | John W. Pope | Leonard L. Tripp |
| Ben C. Johnson | | Howard L. Wolfman |

*Member Emeritus

Also included are the following nonvoting IEEE Standards Board liaisons:

Satish K. Aggarwal
Alan H. Cookson
Chester C. Taylor

Mary Lynne Nielsen
IEEE Standards Project Editor

Contents

| | | |
|------|--|----|
| 1. | Overview..... | 1 |
| 1.1 | Scope..... | 1 |
| 2. | References..... | 2 |
| 3. | Definitions..... | 2 |
| 4. | Overview of technical considerations..... | 4 |
| 4.1 | Telecommunication facilities..... | 4 |
| 4.2 | Faults on power systems..... | 4 |
| 4.3 | Power station ground grid impedance to remote earth..... | 5 |
| 4.4 | Establishing net fault current values..... | 7 |
| 4.5 | Division of fault current..... | 7 |
| 4.6 | Calculating the inducing current..... | 8 |
| 4.7 | Ground potential rise (GPR)..... | 8 |
| 4.8 | Sources of fault and inducing current information and impedance to remote earth information and related responsibilities of power utilities and serving telecommunication utilities..... | 8 |
| 4.9 | Transient voltages resulting from power system operation..... | 9 |
| 4.10 | Types of wire-line telecommunication circuits usually requested for electric power stations as defined by some power utilities..... | 9 |
| 4.11 | Service types and performance objectives for telecommunication services provided at power stations as defined in IEEE Std 487-1992..... | 10 |
| 5. | Electrical power station GPR..... | 10 |
| 5.1 | Determination of appropriate symmetrical and asymmetrical GPR..... | 11 |
| 5.2 | Duration of the fault and its relationship to wire-line telecommunication requirements for power system protection..... | 33 |
| 5.3 | Extraordinary possibilities..... | 35 |
| 5.4 | Example of a GPR calculation and volt time area calculation..... | 36 |
| 5.5 | Summary..... | 51 |
| 6. | Calculation of electromagnetic induction under power fault conditions..... | 52 |
| 6.1 | Inducing current..... | 53 |
| 6.2 | Mutual impedance..... | 53 |
| 6.3 | General formula..... | 57 |
| 6.4 | Examples of calculations..... | 57 |
| 6.5 | Cumulative mutual impedance and electromagnetic induction curves..... | 67 |
| 6.6 | Correction for difference in line heights..... | 68 |
| 6.7 | Electric supply line with double-end feed..... | 68 |
| 6.8 | Fault location for maximum induced voltage..... | 68 |
| 6.9 | Shield factor..... | 69 |
| 6.10 | Typical supply line fault current distribution..... | 76 |
| 6.11 | Example 3: Double-ended supply feed..... | 77 |
| 7. | Vectorial summation of a GPR with an LI voltage..... | 82 |

| | | |
|------|---|-----|
| 7.1 | Calculating the resultant voltage..... | 83 |
| 8. | Power system fault current probability | 87 |
| 8.1 | Probability analysis | 87 |
| 9. | ZOI of GPR..... | 88 |
| 9.1 | Conductive interference | 88 |
| 9.2 | Equipotential lines | 89 |
| 9.3 | Potential contour surveys..... | 91 |
| 9.4 | Effects of GPR within the ZOI | 94 |
| 9.5 | Transfer of a GPR | 95 |
| 9.6 | Determining the magnitude of the GPR in the vicinity of an electric power station or transmission line tower | 95 |
| 9.7 | Cases | 97 |
| 9.8 | Determination of the boundary of the ZOI | 105 |
| 9.9 | Safety considerations | 108 |
| 10. | Summary of mitigating and reduction factors applicable to GPR or induced voltages, or both | 108 |
| 10.1 | Mitigating factors applicable to fault current calculation | 109 |
| 10.2 | Mitigating factors applicable to GPR calculations | 111 |
| 10.3 | Reduction or multiplication design factors to be used with the calculated GPR..... | 112 |
| 10.4 | Chemical grounds | 112 |
| 11. | Communication channel time requirements | 113 |
| 11.1 | Power system fault protection..... | 113 |
| 11.2 | Protective relay types..... | 114 |
| 11.3 | Communication systems factors | 114 |
| 11.4 | Relaying schemes..... | 116 |
| 12. | Administrative guidelines for coordination between communication and power utilities | 119 |
| 12.1 | Acquiring data on substation electrical environments | 119 |
| 12.2 | Studies of substation electrical environment | 120 |
| 13. | Bibliography | 120 |

IEEE Recommended Practice for Determining the Electric Power Station Ground Potential Rise and Induced Voltage From a Power Fault

1. Overview

Difficulties are experienced by telecommunication, protection, and relay engineers in determining the “appropriate” values of power station ground potential rise (GPR) or the longitudinally induced (LI) voltages into wire-line telecommunication facilities including their probability, waveform, and duration, which are to be used in the developing the specifications for systems and component protection.

Suitably rated protection devices are required for personnel safety and for the protection and continuity of service for wire-line facilities that either enter electric power stations or that are otherwise exposed to the influence of high-voltage electric power circuits. (See IEEE Std 487-1992.¹)

1.1 Scope

This recommended practice provides guidance for the calculation of power station GPR and LI voltages, as well as guidance for their appropriate reduction from worst-case values for use in metallic telecommunication protection design. Information is also included for the determination of the following:

- a) The fault current and the earth return current. (The probability, waveform, and duration of these currents and the impedance to remote earthing points used in these GPR and LI calculations as well as the effective X/R ratio are discussed.)
- b) The zone of influence (ZOI) of the power station GPR.
- c) The calculation of the inducing currents, the mutual impedance between power and metallic telecommunication facilities, and shield factors.
- d) The channel time requirements for metallic telecommunication facilities where noninterruptible channels are required for protective relaying.

¹Information about references can be found in Clause 2.

2. References

This recommended practice shall be used in conjunction with the following publications. When the following standards are superseded by an approved revision, the revision shall apply.

IEEE Std C37.90-1989 (Reaff 1994), IEEE Standard for Relays and Relay Systems Associated with Electric Power Apparatus (ANSI).²

IEEE Std C37.93-1987 (Reaff 1992), IEEE Guide for Power System Protective Relay Applications of Audio Tones Over Telephone Channels (ANSI).

IEEE Std 80-1986 (Reaff 1991), IEEE Guide for Safety in AC Substation Grounding (ANSI).

IEEE Std 81-1983, IEEE Guide for Measuring Earth Resistivity, Ground Impedance, and Earth Surface Potentials of a Ground System (Part 1) (ANSI).

IEEE Std 81.2-1991, IEEE Guide for Measurement of Impedance and Safety Characteristics of Large, Extended or Interconnected Grounding Systems (Part 2) (ANSI).

IEEE Std 487-1992, IEEE Recommended Practice for the Protection of Wire-Line Communication Facilities Serving Electric Power Stations (ANSI).

3. Definitions

This clause contains key terms as they are used in this recommended practice.

3.1 auroral effects: Electrical voltages and currents on the earth due to emission of particle energy from the sun.

3.2 direct-current (dc) offset: The difference between the symmetrical current wave and the actual current wave during a power system transient condition. Mathematically, the actual fault current can be broken into two parts: a symmetrical alternating component and a unidirectional dc component, either or both with decreasing magnitudes (usually both). The unidirectional component can be of either polarity, but it will not change polarity during its decay period and will reach zero at some predetermined time.

3.3 direct-current (dc) offset factor: The ratio of the peak asymmetrical fault current to the peak symmetrical value.

3.4 earth resistivity: The measure of the electrical impedance of a unit volume of soil. The commonly used unit is the ohm-meter, ($\Omega \cdot m$), which refers to the impedance measured between opposite faces of a cubic meter of soil.

3.5 effective X/R ratio: The value of X/R as seen from the fault location looking back into the power system far enough to include the reduction of the X/R ratio due to the effects of the terminal apparatus.

3.6 geomagnetic induced currents (GIC): Spurious, quasidirect currents flowing in grounded systems due to a difference in the earth surface potential caused by geomagnetic storms resulting from the particle emission of solar flares erupting from the surface of the sun.

²IEEE publications are available from the Institute of Electrical and Electronics Engineers, 445 Hoes Lane, P.O. Box 1331, Piscataway, NJ 08855-1331, USA.

3.7 ground potential rise (GPR): The product of a ground electrode impedance, referenced to remote earth, and the current that flows through that electrode impedance.

3.8 inducing current: The current that flows in a single conductor of an electric supply line with ground return to give the same value of induced voltage in a telecommunication line (at a particular separation) as the vectorial sum of all voltages induced by the various currents in the inductive exposure as a result of ground fault.

3.9 longitudinal voltage: A voltage acting in series with the longitudinal circuit.

3.10 mutual impedance: The ratio of the total induced open-circuit voltage on the disturbed circuit to the disturbing electric supply-system phase current, with the effect of all conductors taken into account.

3.11 per-unit system (pu): The reference unit, established as a calculating convenience, for expressing all power system electrical parameters on a common reference base. One per unit (pu) is 100% of the base chosen. The pu system in power systems engineering is used to obtain a better comparison of the performance of the power system elements of different ratings, similar to the decibel system used for equating the losses and levels of different telecommunication systems.

3.12 remote earth: That distant point on the earth's surface where an increase in the distance from a ground electrode will not measurably increase the impedance between that ground electrode and the new distant point.

3.13 subtransient reactance: The reactance of a generator at the initiation of a fault. This reactance is used for the calculation of the initial symmetrical fault current. The current continuously decreases, but it is assumed to be steady at this value as a first step, lasting approximately 0.05 s after a suddenly applied fault.

3.14 susceptibility: The property of equipment that describes its capability to function acceptably when subjected to unwanted interfering energy.

3.15 synchronous reactance: The steady-state reactance of a generator during fault conditions used to calculate the steady-state fault current. The current so calculated excludes the effect of the automatic voltage regulator or governor.

3.16 telluric currents: Currents circulating in the earth or in conductors connecting two grounded points due to voltages in the earth.

3.17 transient reactance: The reactance of a generator between the subtransient and synchronous states. This reactance is used for the calculation of the symmetrical fault current during the period between the subtransient and steady states. The current decreases continuously during this period but is assumed to be steady at this value for approximately 0.25 s.

3.18 volt-time area: The area under a curve plotted with voltage versus time with areas of positive and negative polarities added algebraically. The volt-time area that is generally of concern consists of the net accumulated volt-time area that occurs during a certain number of power frequency cycles of the ground potential rise (GPR). The area is a function of the magnitude and decay rate of the dc offset.

3.19 X/R ratio: The ratio of the system inductive reactance to resistance. It is proportional to the time constant L/R and is, therefore, indicative of the rate of decay of any dc offset. A large X/R ratio corresponds to a large time constant and a slow rate of decay, whereas a small X/R ratio indicates a small time constant and a fast rate of decay of the dc offset.

3.20 zone of influence (ZOI): An area around a ground electrode bounded by points of specified equal potential resulting from the voltage drop through the earth between the ground electrode and remote earth.

4. Overview of technical considerations

This recommended practice considers the following:

- a) The various types of power transmission and distribution systems with respect to fault currents and fault current distribution
- b) The nature (type and location) of the faults and their determination using symmetrical component techniques
- c) The characteristics (impedances, inductances, and capacitances) of the power system and related time constants
- d) The characteristics (impedance, susceptibility, etc.) of the affected wire-line telecommunication systems
- e) The determination of the value of the station ground grid impedance to remote or true earth
- f) The determination of appropriate values of the GPR and the LI voltage and their summation and duration under varying conditions
- g) The application of probability and mitigating factors to provide more realistic and acceptable values consistent with required reliability and safety, which could affect economic decisions and trade-offs
- h) The ZOI of the GPR
- i) The rise, duration, and decay of both symmetric and asymmetric fault currents
- j) The time requirements for telecommunication channels when used for protective relaying
- k) The effects of high-voltage direct-current (HVDC), telluric, or auroral currents, or all, as well as dc power system neutral currents that can affect wireline facilities or protective devices
- l) A few typical examples of GPR and induced voltage calculations

4.1 Telecommunication facilities

Telecommunication facilities that contain metallic components and serve electric power stations provide telecommunication circuits for a wide variety of services. Some of the telecommunication services are used for control and protective relaying purposes and are usually considered noninterruptible with respect to the occurrence of power system faults. Whenever faults involving a particular power station occur, any resulting station GPR or LI, or both, appear between the telecommunication facilities and power-station ground. Telecommunication facilities that merely pass through the ZOI of the power station may also be subject to similar interference; however, their service reliability requirements are usually not the same. The magnitude, waveform, and duration of the abnormal interfering voltages should be accurately determined to protect telecommunication facilities entering the power station or passing through the station ZOI.

4.2 Faults on power systems

Power system faults can occur at any point on a power line or in any type of power station at any voltage level. Each location has different fault characteristics. Faults can be single line-to-ground (L-G), phase-to-phase, open-phase, double line-to-ground (2L-G), or three-phase, and can progress from one to the other. These faults can theoretically be initiated at any point on the voltage or current waveform, and the resulting fault currents can attain values higher than 100 kA in North American systems. The resulting GPR or LI, or both, on adjacent telecommunication facilities can be minimal or quite high. Values of the GPR as high as 25 kV_{rms} are possible under unusual circumstances; however, most values are less than 10 kV. The waveform of the GPR voltage can vary from the symmetrical to the fully offset, as described in 5.1.5. The decay time of the direct-current component (dc offset) of the fault current may have a duration of several cycles.

Fault-current studies should be re-evaluated at least every five years and more often, if required, due to the increasing MVA capacity or changing configuration of these power systems.

4.3 Power station ground grid impedance to remote earth

The power station ground grid impedance to remote earth is required in the determination of the inducing current and is used in both GPR and LI calculations.

The total power station ground grid impedance to remote earth, Z_{SGT} , is the total impedance between the power station ground and remote earth and consists of the parallel combination of

- a) Power station ground grid impedance itself, Z_{SG} .
- b) Combined impedance, Z_L , of all high-voltage (HV) and low-voltage (LV) ladder networks. These ladder networks are composed of overhead ground wires or neutrals with multiple tower or pole footing grounds.
- c) Incidental connected impedances, Z_i , such as rails, pipes, etc.

Z_{SGT} can be obtained by either of two methods:

- *Method A*—Calculations based on measurement of earth resistivity only
- *Method B*—Determinations based upon direct measurements

The choice of method will depend upon a variety of circumstances as discussed in the following subclauses.

4.3.1 Method A—Calculations based on measurement of earth resistivity only

Several mathematical models and computer methods are used by power utilities to derive the power station ground grid impedance, Z_{SG} . For example, a formula derived from IEEE Std 80-1986, Equation (39), and good for homogeneous earth where the depth of the grid is less than 0.25 m, is

$$Z_{SG} = \rho \left(\frac{1}{4r} + \frac{1}{L} \right)$$

where

- Z_{SG} is the power station ground grid impedance (Ω);
- ρ is the earth resistivity (obtained by field measurements) ($\Omega \cdot m$);
- r is the equivalent radius of a power station ground grid (radius of a circle having the same area as the station ground grid) (m);
- L is the total length of buried horizontal ground conductors (m).

In GPR studies, calculations of the impedance of all connected overhead ground wire/tower ladder networks are required.

The impedance of a ladder for sufficiently long lines is

$$Z_L = \frac{Z_s}{2} + \sqrt{\frac{Z_s^2}{4} + Z_s Z_p}$$

where

- Z_L is the combined impedance of ladder networks (Ω);
- Z_s is the per-span self-impedance of the overhead ground wire (Ω);
- Z_p is the tower/pole footing impedance(Ω).

The third component, Z_i (incidental grounds) is not amenable to calculation and is omitted in this method because it can be changed without knowledge of the power utility. This omission results in an estimate of GPR that is conservative.

4.3.2 Method B—Determination based upon direct measurement

The total station ground impedance, Z_{SGT} , can be measured with the station in its operational state (all normally externally grounded metallic conductors connected). Such conductors include ladder network impedance, Z_L , and incidental grounds, Z_i (for example, metallic water, gas, sewer lines, and others).

Since these connections exist when the power station is operational and since they increase the effective area of the ground grid and reduce its impedance to remote earth, they should be in place when the impedance measurement is made. Power utilities generally measure the grid impedance immediately after a new grid is constructed but before any intentional ground connections are made. This measurement is useful to check the grid against its design objective, but in itself would not be the correct value to use for GPR calculations.

The fall-of-potential method of measurement, described in IEEE Std 81.2-1991, is appropriate for the measurement of the magnitude and phase of the impedance to earth of large grids. Refinements of this method using modern instrumentation are described in various IEEE publications (see Clause 2).

If, subsequent to the measurement, any of the incidental connections should be removed, measurements should be repeated.

4.3.3 Evaluations and applications of methods A and B

- a) *Accuracy.* Both methods require measurements, and the accuracy of each depends upon the completeness and care with which such measurements are made. Method A requires only measurements of ρ (earth resistivity). In areas of homogeneous soils a single measurement in the near vicinity of an existing or proposed station is usually all that is required; however, some utilities require that several measurements be made. In nonhomogeneous soils, where ρ may vary markedly with both horizontal displacement and depth, multiple measurements are required to categorize ρ adequately in the area of interest. This requirement is particularly true in the calculation of Z_L for long transmission lines that traverse varying terrains. Method B, on the other hand, requires measurement at an existing station with the test conductors extending outward to points beyond the influence of the station ground grid (including overhead ground wires, neutrals, and incidental grounds). Care should be exercised so that coupling between these extended ground conductors and the test leads does not introduce measurement errors.
- b) *Applications.* Method A is the only way to predict the GPR of electric power stations that have not yet been built. This method is particularly accurate for stations with relatively uncomplicated and singular grid structures. In nonhomogeneous soil earth areas, multiple measurements of earth resistivity are required to ensure accuracy. More complicated ground structures or situations require increasingly complex calculations, to the point that stations with two or more interconnected grids may be beyond the present calculating capabilities of some power utilities. Whether method A or B is used to calculate GPR for an existing station, method A calculation techniques are required to predict the effect of future changes in power line and grounding arrangements.

Method B can only be used on existing stations and is particularly useful for extremely complicated stations such as those that have multiple interconnected ground grids. This method is a practical way to determine the Z_{SGT} of older stations, where growth and modifications have resulted in complex ground structures or

where corrosion may have reduced the effectiveness of the grounding structure. Method B ignores the effects of coupling between fault-current carrying conductors and overhead ground wires or other grounded conductors, resulting in errors in the conservative (higher GPR) direction (unless the phase conductors are used for current injection). Similarly, the test voltages used in Method B are usually too low to flashover the insulators of insulated overhead ground wires; hence, the resulting GPR values will be higher (more conservative) where insulated overhead ground wire systems are in place because such conductors do not form part of the measured circuit.

As discussed in Clause 5, the determination of the location of a line fault producing the worst-case GPR requires many of the same calculations that are used in Method A, so that Method A may be preferable, including the determination of worst-case line fault locations.

With the wide variation of conditions at different power stations, no one method of determining Z_{SGT} is best for all stations. Each power utility or substation should choose the method or methods best suited to its needs and capabilities. Larger power utilities, having more specialized engineering staffs and adequate computer capabilities, may routinely use Method A supplemented by Method B for special situations. Smaller power utilities and private substation owners may find that Method B is more suitable considering their staff and equipment. The relative costs of obtaining accurate measurements in Method B, of purchasing and operating the necessary computers for Method A, and of purchasing and operating any resulting telecommunication protection equipment are all important considerations in determining the method to be used.

4.4 Establishing net fault current values

Power utilities, in their calculations of zero-sequence fault currents, usually do not take into account the conductive effects of the transmission and distribution line grounding network impedances (comprising overhead ground wires, neutrals, transmission tower and distribution pole footing impedances, counterpoises, and station ground grid impedances).

The net fault currents should be recalculated by including the effects of the impedances of power line ladder networks, incidental paths (pipes, rails, etc.), telecommunication cable grounds, station ground grids, and a judicious value of fault impedance.

Additional reduction of the induced voltages caused by the net fault current can be achieved by application of various shielding mechanisms available.

Care should be taken in recalculating positive sequence fault currents to include phase shifts in certain transformer windings. Substantial reduction of the net fault current can thus be achieved. The amount of reduction will depend on earth resistivity, tower/pole footing impedances, type and material of overhead ground wire or neutral conductors, span length, transmission or distribution line length, and whether or not overhead ground wire(s) are connected to the station ground grid and whether or not counterpoises and bonds are present.

4.5 Division of fault current

Generally, fault current will, at the point of fault, divide between the metallic return paths and earth. The metallic return paths will include overhead ground wires, neutrals, counterpoises, bonds, station ground grids, commonly grounded telecommunication circuits, and incidental grounds such as rail and metallic pipes. There are many factors controlling the division of power system fault current into its several paths, and calculations are usually quite complex. The determination of an accurate division of fault current requires knowledge of the earth return path impedance and the grounding system (including all other return path impedances), as shown in Clause 5.

4.6 Calculating the inducing current

The purpose for calculating the inducing current flowing in each transmission or distribution circuit connected to the power station under study is twofold:

- a) To determine the amount of fault current induced in each overhead ground wire or neutral. These currents do not cause any GPR.
- b) To determine the amount of voltage induction into nearby telecommunication circuits.

The inducing current that is used to determine the shielding action of overhead ground wires is also used to determine the LI voltage in telecommunication networks.

NOTE—The terms overhead ground wire(s), shield wire(s), static wire(s), and skywire(s) are synonymous.

4.7 Ground potential rise (GPR)

This is essentially the product of

- a) The total ground grid impedance (Z_{SGT}) at the power system fundamental frequency to a true or remote earthing point (has to be outside the ZOI of the GPR)
- b) The total net fault current that flows through the ground grid impedance

These values should be determined by the electric power utility. See IEEE Std 80-1986 and IEEE Std 81.2-1991 for further information.

4.8 Sources of fault and inducing current information and impedance to remote earth information and related responsibilities of power utilities and serving telecommunication utilities

In some power utilities the necessary fault current information can be obtained from a system planning or protective relaying group. The group responsible for the determination of station ground grid impedance will usually be different from the group responsible for determining an overall impedance to a remote earthing point, including any telecommunication cable shields. Serving telecommunication utilities may be involved in this latter determination. In any event, the power utility is essentially responsible for assessing the validity of these parameters and determining the “appropriate” net fault current value to be used in the GPR calculation, its wave form and duration, and the magnitude of the inducing current. The responsibility for determining the magnitude of the GPR, the induced voltage, and their sum is that of the power utility with the cooperation of the associated telecommunication utility.

Since the electric power system originates the fault-produced interfering voltages into the telecommunication facilities serving the power station, the power utility is responsible for the accurate determination of the GPR and the induced voltage for both present and future power system arrangements by considering

- a) The impedance of the power station ground grid to remote earth
- b) The earth return fault current (its wave form and duration) that flows through the grid and produces the GPR
- c) The effective X/R ratio of the power system at the fault location
- d) The extent of the power station ZOI along the route of the serving telecommunication cable

- e) Fault current values and maps of the relevant power feed routes as required by a serving telecommunication utility for the computation of fault-produced induction on the serving telecommunication cables
- f) The noninterruptible channel time requirements

Since the telecommunication facilities extend into the power station to provide telecommunication service, the power utility or substation owner should advise a serving telecommunication utility of the fault-produced environment. This provision of fault-related data applies even to those cases in which the power utility or substation owner, rather than the serving telecommunication utility, provides the telecommunication protection equipment at the power station.

The telecommunication company and the power utility or substation owner should cooperate closely in determining the sum of the GPR and the induced voltage. A great deal of cooperation and trust should exist between the power utility or substation owner and the serving telecommunication company representatives, as well as with individuals within these organizations, in order to determine satisfactorily the nature of the hostile environment of the power station.

4.9 Transient voltages resulting from power system operation

Surges or transients, either unidirectional or oscillatory and usually having fast rise times, are produced by power system switching operations. These stem from switching operations involving breakers, transformer tap changers, capacitors, etc., and often result in relatively high-magnitude, short-duration voltages being induced into telecommunication wires or cables. This recommended practice is confined to the fundamental frequency and its dc offset and does not discuss surges or transients.

4.10 Types of wire-line telecommunication circuits usually requested for electric power stations as defined by some power utilities

- a) All-metallic circuits between terminals for dc and ac signals, including audio tone, that can be interrupted prior to, during, or after power system faults (noncritical channels)
- b) Nonmetallic (for example, audio tone) circuits that can be interrupted prior to, during, or after power system faults, or both (noncritical channels)
- c) All-metallic circuits between terminals for dc and ac signals, including audio tone, that cannot be interrupted (critical channels)
- d) Nonmetallic (for example, audio tone) circuits that cannot be interrupted (critical channels)

These types of services may have various requirements regarding time and fidelity of output versus input, etc.

A noninterruptible telecommunication channel usually implies that the channel be uninterrupted prior to, during, and immediately following the power fault. This document provides guidance for the time requirements of telecommunication channels relative to the various classes of power system telecommunications, including protective relaying channels prior to, during, and after the fault or circuit breaker operation.

To some degree, the assumed appropriate values of interfering voltages may well be influenced by the reliability requirements.

4.11 Service types and performance objectives for telecommunication services provided at power stations as defined in IEEE Std 487-1992

Wire-line telecommunication services into electric power stations are classified into four major types according to the following definitions:

- a) *Type 1.* Services requiring either dc transmission or ac and dc transmission used for
 - 1) Basic exchange telephone service, private line, or both; voice telephone service, etc.
 - 2) Teletypewriter, telemetering, supervisory control, etc.
- b) *Type 2.* Private line services requiring ac or dc transmission, or both, used for pilot wire protective relaying or dc tripping
- c) *Type 3.* Private line services requiring ac-only transmission used for telemetering, supervisory control, data, any noncritical audio tone applications, etc.
- d) *Type 4.* Private line services requiring ac-only transmission used for audio tone protective relaying

Interruptions or outages due to the effects of power system faults can be minimized through the installation and maintenance of special protection systems that are designed to operate in the fault-produced, electrical environment (GPR and LI) at electric power stations. Because of the critical need for service continuity during power system faults on certain types of telecommunication services provided to power stations, a system of optional service performance objective classifications for the purpose of this recommended practice has been established for all types of telecommunication services provided to power stations. These objectives, with respect to the effects of power system faults, fall into three classifications. They are

- *Class A.* Noninterruptible service performance (should function before, during, and after the power fault condition)
- *Class B.* Self-restoring interruptible service performance (should function before and after the power fault condition)
- *Class C.* Interruptible service performance (can tolerate a station visit to restore service)

5. Electrical power station GPR

In order to determine the appropriate value of voltage that a station ground grid may attain relative to a remote ground point (hereafter called GPR) as a function of time, consideration should be given to the following:

- a) The complete data on the power system impedances, currents, and voltages for power system faults, alternate return paths such as overhead ground wire, water pipes, rails, etc.
- b) The fault locations that produce the worst combination of the GPR and the induction
- c) The duration and waveform (dc offset) of the voltages and currents for the case of the worst fault

NOTE—This assumes an evaluation of the assumed point on the voltage or current waveform for fault initiation.

- d) The ground grid impedance at the power station ground grid with respect to remote earth, and the impedance with respect to remote earth at the remote fault location
- e) The calculation of appropriate fault current values, due to the conductive effects of grounding
- f) The calculation of the GPR, induced voltages, and their vectorial sum
- g) The reduction of induced voltage due to shielding effects of transmission line conductors, overhead ground wires, and telecommunication cable shields
- h) The reduction of the GPR due to overhead ground wires

5.1 Determination of appropriate symmetrical and asymmetrical GPR

5.1.1 GPR

When a ground fault occurs, the zero-sequence fault current returns to the power system ground sources through the earth and also through alternate paths such as neutral conductors, unfaulted phases, overhead ground wires, messengers, counterpoises, and metallic cable shields. The ground sources are the grounded wye-connected windings of power transformers, generator grounds, shunt capacitors, frequency changers, etc. The GPR is equal to the product of the station ground grid impedance and that portion of the total fault current that flows through it. Also, the GPR is equal to the product of the alternate path impedance and that portion of the conductively coupled fault current that flows through it. The volt-time area of GPR to be determined is given in volt-seconds for the duration of the fault.

5.1.2 Ground grid impedance

Since the station ground grid impedance to remote earth is needed to calculate the GPR, the ground grid impedance shall be obtained either by the calculation or measurement methods described in 4.3.

5.1.3 Ground fault studies

A study should be made of various ground faults in order to determine the one that produces the highest GPR and volt-second area (see 5.4.4). The station ground grid impedance, as well as power overhead ground wire and telecommunication grounding networks, tend to limit the fault current and should be included in the calculations.

5.1.4 Power system generators

In the ground fault study (see 5.1.3), the power system generators are usually represented by their subtransient reactances. As the time progresses until fault clearing, their reactances increase to their transient values and possibly to their steady-state synchronous reactances. This change can be neglected in most cases and the initial subtransient reactance retained. All significant impedances should be included, such as for transmission lines.

5.1.5 DC offset

The initial magnitude of the dc offset should be calculated as a function of the voltage magnitude at the time the fault is initiated. The highest dc offset occurs when the change in current, from just before fault initiation to just after fault initiation, is maximum. Since the alternating current cannot change state instantaneously due to the inductance of the circuit, initially the dc offset counter balances the change in alternating current. The dc offset then decreases to zero at a rate determined from the effective reactance-impedance ratio of the power circuit at the fault. With a highly inductive circuit, the maximum dc offset will occur when the fault is initiated close to a voltage zero crossing, a condition that is most unlikely for faults resulting from insulation breakdown. Also, a highly inductive circuit will have a prolonged dc offset. For the application of a multiplication factor for dc offset, refer to Clause 10.

Ground potentials differ from magnetically induced voltages. The transient dc component (dc offset) of the ground fault current produces a proportional but decaying ground potential. Equation (24a), used to determine the instantaneous current considering both the symmetrical and dc offset components, is included in 5.4.3. For induced voltages, the dc component is of minor importance since the induced voltage varies as di/dt . In HV networks when the fault impedance is negligible, the time constant varies; but the rate of decay of the dc component is usually within 5–40 ms and is determined by the effective power system X/R ratio. The ground fault current contains nearly a full transient or dc component if the ground fault is initiated close to voltage zero, the probability of which is very low. This is the instant when the resulting fault current will be at maximum. This near worst-case scenario can happen when the ground fault is caused initially by a light-

ning stroke or when a circuit breaker is closed into a fault. In this latter case, the pre-strike arc impedance of the breaker has the effect of reducing the initial magnitude of the dc offset. Table 1 has multiplication factors to be used on root-mean-square (rms) values to determine the total maximum peak value.

Table 1—Factors to be used to account for maximum effect of dc offset on peak fault current

| <i>X/R</i> ratio | Multiplication factor |
|------------------|-----------------------|
| 1 | 1.04 |
| 2 | 1.21 |
| 3 | 1.35 |
| 4 | 1.46 |
| 5 | 1.53 |
| 6 | 1.59 |
| 7 | 1.64 |
| 8 | 1.68 |
| 9 | 1.71 |
| 10 | 1.73 |
| 15 | 1.81 |
| 20 | 1.85 |
| 30 | 1.90 |
| 40 | 1.92 |
| 50 | 1.94 |

The shielding factor of cables for the transient dc component is poorer than the value measured at the power frequency. Moreover, a simultaneous dc component may also influence the ac shield factor of armored cables. On the other hand, the effective impedance to earth of ground electrodes containing long buried wires or cable sheaths and of lines equipped with shield wires is lower for the dc component than for the ac component.

5.1.6 Different combinations of GPR

There are four possible combinations of circumstances involving power faults that should be considered in determining the worst-case GPR at a power station. With reference to Figure 1, four different ground fault conditions causing GPR at the local power station (local ground source) will be described. For simplicity, a single-circuit, three-phase power line with two ground sources is illustrated. A ground source at a power station is a component that can supply current to a fault and to which current returns by way of the earth and all available metallic conducting paths. Ground sources include wye-connected transformers with grounded neutrals, grounded autotransformers, and grounded generators.

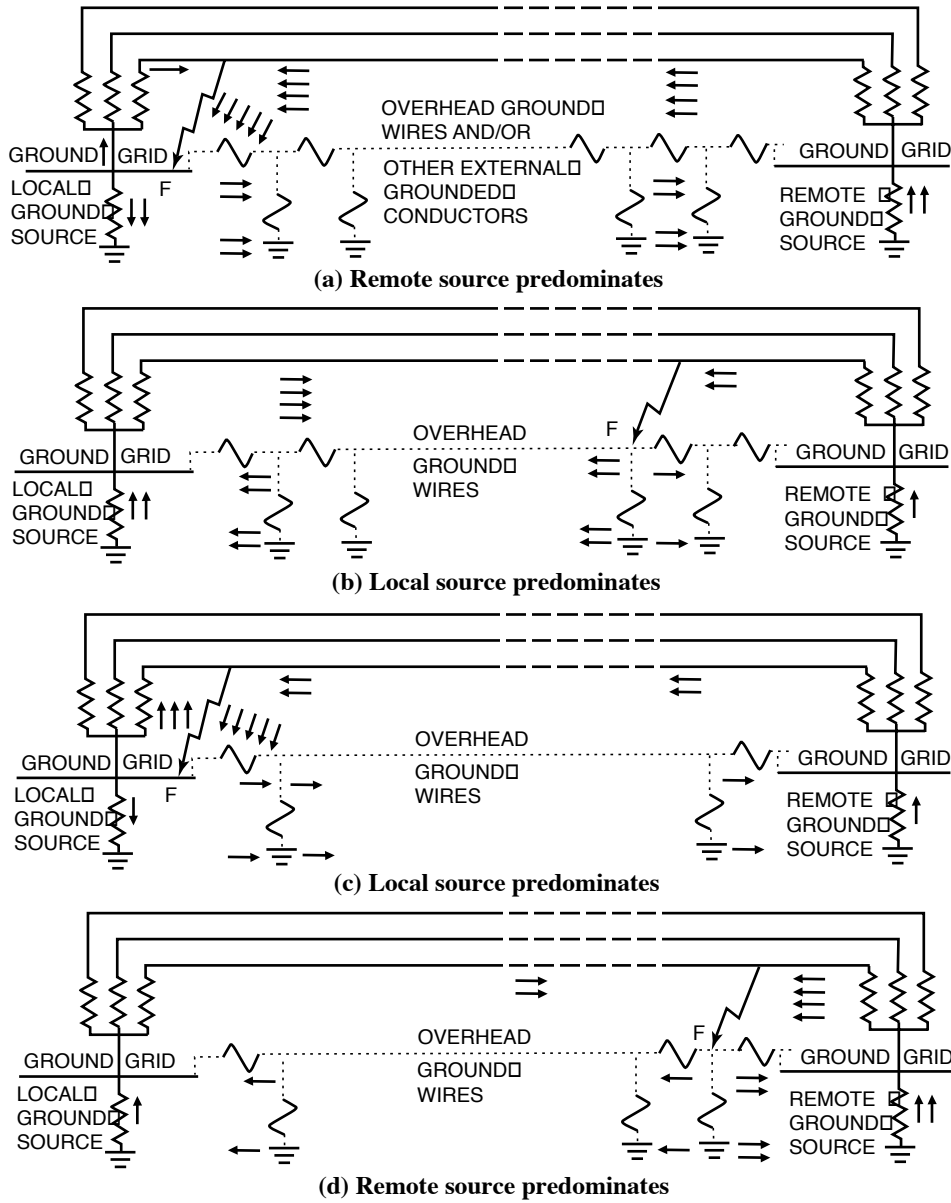

NOTE 1—For simplicity, a single line with only two ground sources is illustrated.

NOTE 2—Overhead ground wires can be insulated from the towers, resulting in different values.

NOTE 3—F-fault location.

Figure 1—Different combinations of GPR occurring at the local ground source

- a) Figure 1a illustrates the situation involving a fault to the local ground grid where the remote source provides a greater amount of fault current than the local source (the remote source “predominates”). In this case, the current supplied by the local source simply circulates on the metallic grid (very little flows into the earth), therefore not producing any appreciable GPR. However, the relatively large current from the remote source returns to that source by way of the earth and all available metallic conductors, thereby producing a relatively large GPR at the local power station.

- b) Figure 1b illustrates the situation involving a line fault to remote earth (the fault location is outside the ZOI of the local power station) where the local source provides a greater amount of fault current than the remote source (the local source “predominates”). In this case, the fault currents return to their respective sources by way of the earth and all available conductors. Since the local source supplies the high-fault current, the GPR produced at the local power station will be relatively large.
- c) Figure 1c illustrates the situation involving a fault to the local ground grid where the local ground source provides a greater amount of fault current than the remote source (the local source “predominates”). The current supplied by the local source mostly does not flow into the earth and does not produce any appreciable GPR. The relatively small current from the remote source returns to that source by way of the earth and all variable metallic conductors, thereby producing a relatively small GPR at the local station.
- d) Figure 1d illustrates the situation involving a line fault to remote earth where the remote source provides a greater amount of fault current than the local source (the remote source “predominates”). The fault currents return to their respective sources by way of the earth and all available conductors. However, since the local source provides a relatively small current, this GPR produced at the local power station will be relatively small.

NOTE 1—In these examples, the cases described in items a) and b) resulted in the largest GPRs at the local power station. However, all four fault conditions should be evaluated to determine the worst-case GPR at the power station of interest.

NOTE 2—Figure 1 shows a typical system, in which the externally grounded metallic conductors (including overhead ground wires) are indicated by dotted lines. Overhead ground wire systems are constructed in various configurations and may be either directly bonded to the transmission line towers or may be insulated from the towers. In addition, overhead ground wire systems may be directly connected to the station ground grid or may be terminated one or more spans out from the station. The externally grounded metallic conductors, including grounded wires, provide an alternate path for the fault current, reducing the earth return portion of the total fault current.

NOTE 3—Power stations without ground sources (for example, switchyards with transformers having only delta connections) do not experience GPR from line faults occurring off the station grid when the power line overhead ground wire is not connected to the station ground grid. However, such stations do experience a GPR if a fault occurs directly to the grid and the system connection on the other end has a ground path. For example, the transformer at the other end has a grounded winding.

5.1.7 Determination of the worst-fault location

A complex power station may have a large number of rights-of-way (ROW) with multicircuit power lines on each ROW. These circuits may be operated at different voltage levels. A fault current study for an L-G fault at each transformer voltage level should be produced. Each fault current study should be examined as follows:

- a) If the vectorial sum of all zero-sequence fault current contributions to the transformer bus fault from all transmission and distribution lines entering the station under study is greater than the sum of all current contributions from all grounded sources at that station (including generators, grounded transformers, shunt capacitors, etc.), then at the voltage level for which the fault current study is presently being examined, the bus fault will usually produce a worse GPR than the line fault.
- b) If the reverse is true, that is, the vectorial sum of the line contributions is smaller than the local ground source current sum, the line fault will produce a greater GPR. This is because the local ground current will return partially, in the case of the line fault, through the station ground impedance, adding to the GPR caused previously by the line current contribution. In the bus fault case, the current merely circulates through the faulted transformer winding, the station ground bus, and the fault impedance.

Having determined the worst-fault location (bus versus out on-the-line), to select that fault current study with the highest fault current is not appropriate. Variances between grounding networks of lines with the var-

ious voltage levels may, for instance, cause the study showing lower zero-sequence fault currents to result in a GPR greater than that caused by the higher currents. Instead, all faults should be investigated for fault locations as determined above.

5.1.8 Determination of the worst-fault type

Basically, three types of faults should be investigated:

- a) *Line-to-ground faults (L-G)*. These are predominant in terms of frequency of occurrence. Zero-sequence and positive-sequence currents will be required. In practice, GPR is a function of zero-sequence currents only, but positive-sequence currents are required to determine magnitudes of the individual zero-sequence currents flowing in each phase of the faulted circuit.
- b) *Double line-to-ground faults (2L-G)*. These are statistically less frequent than L-G faults but could produce zero-sequence currents far exceeding those caused by L-G faults. Theoretically, this is because of different connections of sequence networks during these faults. For an L-G fault, the positive-sequence, negative-sequence, and zero-sequence networks are connected in series and driven by the prefault voltage source; whereas, for a 2L-G fault, positive-sequence impedance is connected in series with the parallel combination of zero-sequence and negative-sequence impedances, with less overall impedance in the path of the fault current. [For instance, many high MVA autotransformers may be added to power stations. These could have their primary-to-secondary, or primary-to-tertiary, zero-sequence reactance ratios so high that their primary current is small compared with the tertiary (ground) current. In addition to this, if more such transformers are added to the station, the resulting tertiary currents will be very large due to further paralleling of reactances.]
- c) *Three-phase faults*. These are statistically less frequent than L-G and 2L-G faults. Three-phase faults produce positive sequence currents, and detailed calculations are required to determine magnitudes of the individual zero-sequence currents flowing in each phase of the faulted circuit.

If X_1 and X_0 are positive-sequence and zero-sequence reactances, respectively, of the system impedance at the point of fault and X_1 is less than X_0 , the 2L-G fault will result in higher zero-sequence fault currents, often twice as high as the L-G fault currents calculated at the same fault location. The GPR produced by 2L-G faults is not normally considered, due to its low probability.

For an overview of the frequency of occurrence of different types of faults as a function of voltage levels on which they occur and other parameters, see [B12].

5.1.9 Notes on modeling of ladder networks of long and short lines

As will become clear later, GPR work requires modeling of transmission and multigrounded distribution line grounding networks. This becomes important when determining the amount of fault current carried away from the fault by the grounding network of the line, conductively, by first calculating its impedance to remote earth. This determines the amount of the GPR-causing current.

A modified transmission line theory can be used by modeling the ladder networks by the distributed parameter method. Care should be taken in correcting the classical hyperbolic transmission line equations due to the fact that the series (overhead ground wire self-impedance) and shunt (tower footing impedance) components of the overhead ground wire-tower ladder network are discrete components. This modification should enable one to transform these discrete components into a set of distributed ladder network parameters. This, however, can only be done with lines that are sufficiently long. If the line is short, one should resort to the nodal and mesh analysis that may require considerable computing time, particularly with large ROWs with a multitude of lines and overhead ground wires. The presence of counterpoises and bonds can be extremely complicating, but should be considered.

5.1.10 HV bus fault GPR

By simulating the L-G and three-phase bus faults, power utilities can generally calculate resulting zero-sequence and positive-sequence fault currents as shown in Figure 2.

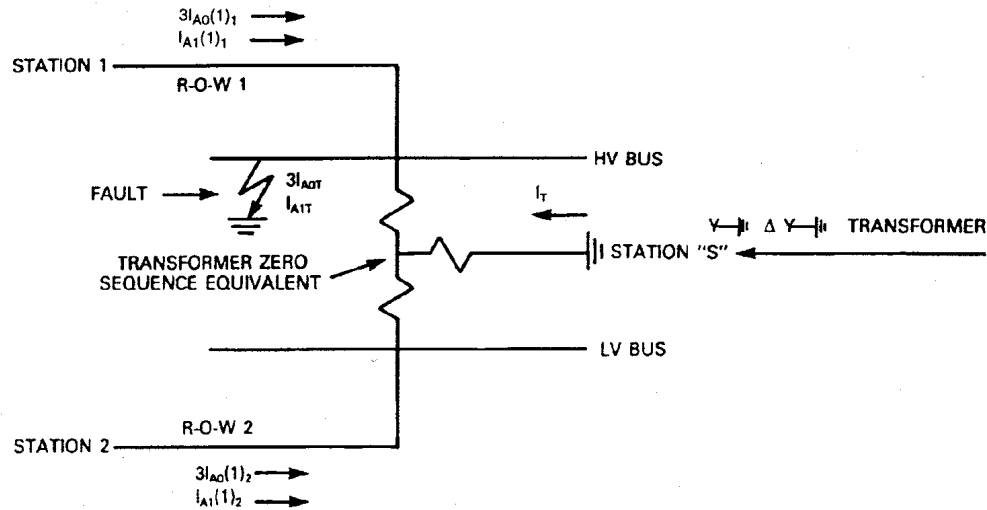

- $3I_{A0(J)_r}$ is the zero-sequence current in the J th circuit on the r th ROW
- $I_{A1(J)_r}$ are the positive-sequence currents in the J th circuit on the r th ROW
- $3I_{A0T}$ is the total zero-sequence fault current
- I_{A1T} is the total positive-sequence fault current
- I_T is the transformer neutral, generator, etc., current

Figure 2—L-G and three-phase fault simulation

NOTE—The fault currents shown in Figure 2 are the per circuit (as opposed to per phase) quantities; that is, all three-phase currents are concentrated in a single equivalent conductor and, in the case of zero-sequence currents, include the inductive effect of ground wires. To account for the conductive effects of the presence of overhead ground wires, station ground impedance, incidental ground path impedances, and phase wire zero-sequence impedances, $3I_{A0T}$ shall be reduced accordingly. A new circuit, valid for electrically long lines, is formed as shown in Figure 3.

Based on Figure 2:

$$\sum_r \left(\sum_J 3I_{A0(J)_r} \right) + I_T = 3I_{A0T} \quad (1)$$

$$\sum_r \left(\sum_J I_{A1(J)_r} \right) = I_{A1T} \quad (2)$$

then

- V_p is the prefault voltage;
- Z_c is the zero-sequence self-impedance of the faulted phase conductor, between the source and fault locations;

- $Z_{\infty T}$ is the parallel combination of impedance of all ladder networks (Z_L) and the incidental impedances (Z_i);
- Z_{sy} is the system impedance;
- Z_a is the fault impedance.

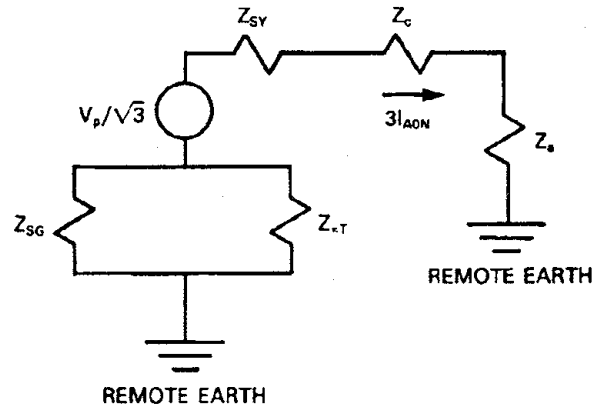

Figure 3—Circuit for total zero-sequence current reduction ($3I_{A0T}$)

Z_{sy} is the impedance seen between the fault terminals, as determined by the power utility in fault calculations, and includes the zero-sequence impedances of lines, transformers, etc.

The new zero-sequence fault current ($3I_{A0N}$) resulting from Figure 3 includes the conductive effects of grounding. This new lower interfering current, however, shall be further reduced by the amount it induces into the overhead ground wires of the tower (or pole) line that carries the faulted circuit. Because of the unequal spacings between the phase wires and neutrals and because each phase carries different currents both in amplitude and phase (faulted phase, depending on the corresponding positive-sequence current, generally carries the current toward the fault location, whereas the remaining two unfaulted phases generally carry currents away from the fault location), unequal currents are induced in the overhead ground wires from each phase of the faulted circuit. Overhead ground wire currents induced from the faulted phase will act as a shield, but those induced from the unfaulted phases will usually subtract from the shielding current and act as an “antishield,” as depicted in Figure 4.

Similar shielding or antishielding will be produced by unfaulted circuits of the faulted tower line and unfaulted tower lines with their circuits on the same ROW, depending on their terminal connections in relation to the faulted circuits. Since the induced overhead ground wire current(s) does not enter ground but stays in the overhead ground wire, therefore causing no GPR, the determination of shielding or antishielding currents is important. Also, telecommunication cable sheaths and messenger strands may act as shields if strategically grounded.

Because of the foregoing conclusion, the per-circuit fault quantities shall be broken down into their respective per-phase equivalents, and induction into the overhead ground wire(s) calculated separately from each phase.

Limiting the analysis to two single-circuit tower lines extending in two directions from station S (as in Figure 2) on two ROWs (ROW 1 and ROW 2), the phase current will be determined as shown in Figure 5.

Positive-sequence currents in Figure 5b are coincidental with those in Figure 2, and their source is the three-phase fault study done by the power utility. The positive-sequence currents in Figure 5a have a superscript (')

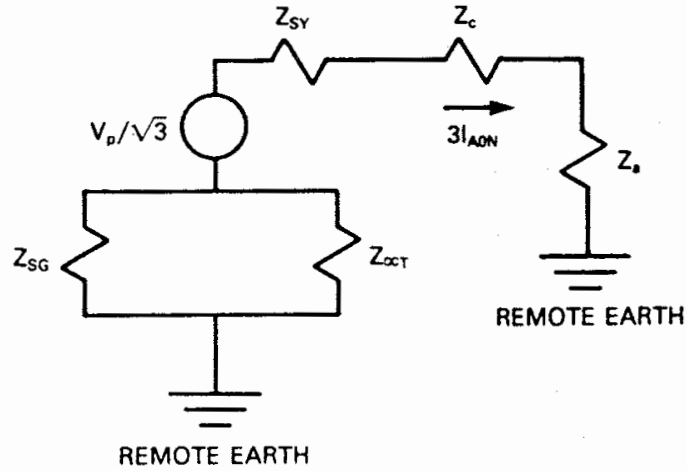

I_{A0} is the faulted phase zero-sequence current contribution
 I_{B0}, I_{C0} are the unfaulted phase zero-sequence current contributions
 I_{SA}, I_{SB}, I_{SC} are the induced currents in the overhead ground wire
 Z_p is the pole tower footing impedance

Figure 4— Power line shielding

because these currents differ from those in Figure 5b since the voltage sources V_{p1} and V_{p2} drive two different circuits.

Here

$$I_{A'1}(1)_1 = \frac{I_{A1}(1)_1}{I_{A1T}} \times \frac{3I_{A0T}}{3} \quad (3)$$

and

$$I_{A'1}(1)_2 = \frac{I_{A1}(1)_2}{I_{A1T}} \times \frac{3I_{A0T}}{3} \quad (4)$$

Then, assuming positive-sequence currents equal negative-sequence currents, the phase currents (I_A , I_B , and I_C) in circuit 1 on ROW 1 are

$$I_A(1)_1 = I_{A0}(1)_1 + I_{A'1}(1)_1 + I_{A2}(1)_1 \quad (5)$$

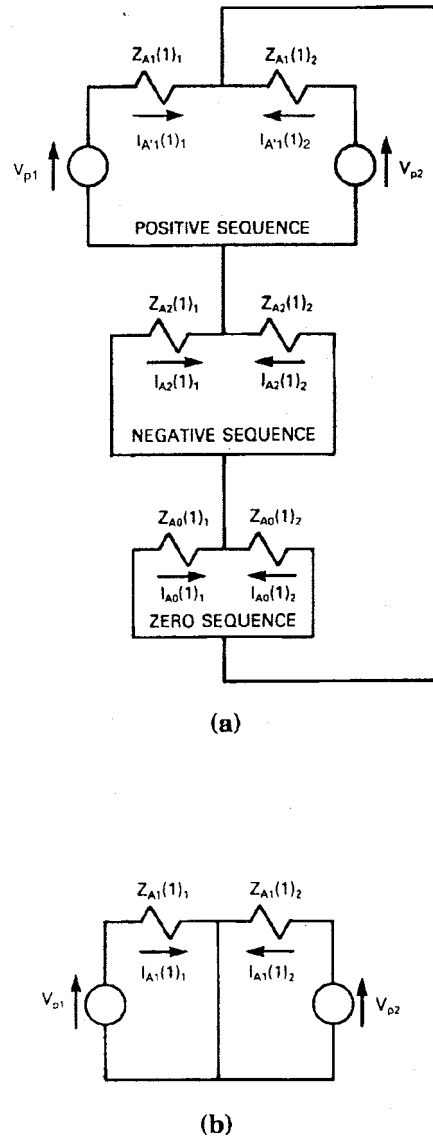

Figure 5— Circuit for L-G and three-phase fault analysis

$$I_B(1)_1 = I_{A0}(1)_1 + a^2 I_{A1}(1)_1 + a I_{A2}(1)_1 \tag{6}$$

$$I_C(1)_1 = I_{A0}(1)_1 + a I_{A1}(1)_1 + a^2 I_{A2}(1)_1 \tag{7}$$

where a is the complex operator ($1 \angle 120^\circ$) and

$$a + a^2 = -1 \tag{8}$$

Similarly, the phase currents I_A , I_B , and I_C in circuit 1 on ROW 2 are

$$I_A(1)_2 = I_{A0}(1)_2 + I_{A1}(1)_2 + I_{A2}(1)_2 \tag{9}$$

$$I_B(1)_2 = I_{A0}(1)_2 + a^2 I_{A1}(1)_2 + a I_{A2}(1)_2 \quad (10)$$

$$I_C(1)_2 = I_{A0}(1)_2 + a I_{A1}(1)_2 + a^2 I_{A2}(1)_2 \quad (11)$$

Substituting the expression for $I_{A1}(1)_1$ [defined in Equation (3)] into Equation (5) and assuming that for one phase-to-ground fault,

$$I_{A1}(1)_1 = I_{A2}(1)_1$$

$$I_{A1T} = I_{A0T}$$

yields the following:

$$I_A(1)_1 = \frac{2I_{A1}(1)_1}{I_{A1T}} \times \frac{3I_{A0T}}{3} + \frac{3I_{A0}(1)_1}{3} \quad (12)$$

Similarly for ROW 2, substituting Equation (4) into Equation (9) and assuming that for one phase-to-ground fault,

$$I_{A1}(1)_2 = I_{A2}(1)_2$$

$$I_{A1T} = I_{A0T}$$

yields the following:

$$I_A(1)_2 = \frac{2I_{A1}(1)_2}{I_{A1T}} \times \frac{3I_{A0T}}{3} + \frac{3I_{A0}(1)_1}{3} \quad (13)$$

Currents in the unfaulted phases are

$$I_B(1)_1 = I_C(1)_1 = \frac{3I_{A0}(1)_1}{3} - \frac{I_{A1}(1)_1}{I_{A1T}} \times \frac{3I_{A0T}}{3} \quad (14)$$

NOTE 1—Equation (14) is obtained by substituting Equation (3) into Equations (6) and (7).

$$I_B(1)_2 = I_C(1)_2 = \frac{3I_{A0}(1)_2}{3} - \frac{I_{A1}(1)_2}{I_{A1T}} \times \frac{3I_{A0T}}{3} \quad (15)$$

NOTE 2—Equation (15) is obtained by substituting Equation (4) into Equations (10) and (11).

Next, mutual impedances between overhead ground wire(s) and each phase conductor on the faulted ROW may be obtained by the use of either the simplified form of Carson's equation [B24] or, more accurately, the "extended complex image" known as Parker's equations [B56]:

Impedance (mutual and self) based on a simplified form of Carson's equation

$$Z_{mCAR} = 0.00159f + j0.004657f \log_{10} \frac{2160 \sqrt{\frac{\rho}{f}}}{d_{ab}} (\Omega/\text{mi}) \quad (16)$$

where

- f is the power system frequency (Hz);
- ρ is the earth resistivity ($\Omega \cdot \text{m}$);
- d_{ab} is the distance between each phase conductor and overhead ground wire(s) (ft);
- Z_{mCAR} is the mutual impedance based on a simplified form of Carson's equation.

NOTE 3—See 6.2 for additional information.

$$Z_{mCAR} = 0.0001f + j0.00289f \log_{10} \frac{2160 \sqrt{\frac{\rho}{f}}}{d_{ab}} (\Omega/\text{km}) \quad (16a)$$

where

- d_{ab} is the distance between each phase conductor and overhead ground wire(s) (m).

Impedance (mutual and self) based on Parker's equation

The self-impedance of each overhead ground wire is calculated as shown in the following equation:

$$Z_{sCAR} = r_c + 0.00159f + j0.004657f \log_{10} \frac{2160 \sqrt{\frac{\rho}{f}}}{GMR} (\Omega/\text{mi}) \quad (17a)$$

where

- r_c is the conductor impedance (Ω/mi);
- GMR is the geometric mean radius of the conductor (ft);
- Z_{sCAR} is the self-impedance of the overhead ground wire based on a simplified form of Carson's equation.

$$Z_{sCAR} = 0.62137r_c + 0.0001f + j0.00289f \log_{10} \frac{2160 \sqrt{\frac{\rho}{f}}}{GMR} (\Omega/\text{km}) \quad (17b)$$

where

- GMR is the geometric mean radius of the conductor (m).

A number of researchers have investigated alternative approximations to Carson's formulation. One formula recommended by CCITT [B10] yields highly accurate results for closely spaced conductors. This, together with Carson's results for far-spaced conductors, forms the basis for the formula derived by J. C. Parker, Jr. of

Bell Laboratories [B56]. The transition between the two formulas is covered by including a term that corrects for close-spaced conductors and that disappears for far-spaced conductors.

The mutual impedance based on Parker's extended complex image equation (Z_{mPAR}) is defined in Equation (25).

It is important that the self-impedance be calculated in the same way as the mutual impedance so that the same approximations and assumptions apply to both. This is necessary because the self-impedance is used in a ratio with the mutual impedance to calculate a shielding factor. Therefore, the accuracy of the shielding factor depends on the relative accuracies of the self- and mutual impedances more so than on the absolute accuracy of each.

An expression for self-impedance can be derived directly from the expression for mutual impedance by assuming that the two conductors are very close together and are separated only by the radius of the conductor in question. A term should be added to this mutual term to account for the flux internal to the conductor to give

$$\left(Z_{sPAR} = r + j \frac{\omega \mu}{8\pi} + Z_{mPAR} (\Omega/\text{km}) \right)$$

internal mutual

where

- r is the dc resistance of conductor (Ω/km);
- ω is the angular frequency (equal to $2\pi f$);
- Z_{sPAR} is the self-impedance of the overhead ground wire based on Parker's extended complex image equation;
- μ is the absolute permeability of conductor; (equal to $\mu_r \mu_0$);

where

- μ_r is the relative permeability of conductor (1 for nonferrous, 50–200 for ferrous);
- μ_0 is the rationalized permeability of free space.

Z_{mPAR} is calculated by Equation (25) (as Z_m), using the conductor radius for separation.

Then, making the substitutions, where

- a is the radius of conductor (m);
- $h_1 = h_2 = h$ is the height of conductor (m);

gives

$$Z_{sPAR} = r + j \frac{\omega \mu_0}{2\pi} \left[\frac{\mu_r}{4} + 1 \ln \left(\frac{D_1}{a} \right) - \frac{1}{12} \left(\frac{2}{\gamma D_1} \right)^4 \right] (\Omega/\text{km}) \quad (17c)$$

where

$$D_1 = \sqrt{a^2 + \left(2h + \frac{2}{\gamma}\right)^2} \text{ (m)}$$

but with h much greater than a ,

$$D_1 = 2h + \frac{2}{\gamma} \text{ (m)}$$

NOTE 4—See Equation (25) for a definition of γ .

The total zero-sequence current induced in each overhead ground wire (I_{sk}) is the sum of the products of each phase current and the coupling factor μ ,

where

$$\mu = \frac{Z_m}{Z_s} \quad (18)$$

and

Z_m is the mutual impedance (Ω/mi or Ω/km);
 Z_s is the self-impedance (Ω/mi or Ω/km).

Z_m and Z_s could be calculated by either simplified Carson's or Parker's formulas depending on spacing of conductors.

Conversely, for the current I_G , flowing in the earth due to induction, the coupling factor $(1 - \mu)$ is

$$(1 - \mu) = 1 - \frac{Z_m}{Z_s} \quad (19)$$

To assess the conductive effects, Z_∞ shall be determined next. Z_∞ is defined as an impedance looking into an overhead ground wire-tower (or neutral-pole) ladder network from the fault terminals. The determination of Z_∞ is complex and can be done by either discrete or distributed parameter methods. In the case of one electrically long line conforming to the inequality,

$$L\sqrt{Z_s Z_p} > 2 \quad (20)$$

where

L is the total length of the line (mi or km);
 Z_s is the per-span self-impedance of the overhead ground wires, (Ω);
 Z_p is the per-span tower (pole) footing impedance (Ω).

then

$$Z_\infty = \frac{Z_s}{2} + \sqrt{\frac{Z_s^2}{4} + Z_s Z_p} \quad (21)$$

Z_{GPR} is the GPR impedance (Ω);

and the GPR is then

$$GPR = I_{GPR} \times Z_{GPR} \quad (24)$$

5.1.11 Low-side bus and line-fault GPR

Theoretically, LV faults can be handled in precisely the same manner as the HV faults. All differences between HV and LV side construction (transformer connections, line conductors, length, pole footing impedance, etc.) will reflect in the calculation of zero- and positive-sequence LV L-G and balanced fault currents. As opposed to HV systems, which usually carry overhead ground wires, some LV lines, delta or wye-connected, carry no neutrals.

When neutrals are present on LV systems, LV bus fault calculations follow the same method described in 5.1.10, and LV line faults will be the same as HV line fault calculations, to be described later.

When neutrals are not present on LV system, both LV bus and line-fault GPR can be calculated using the simplified method shown in 5.1.10. For a LV bus fault, Z_L will consist of the parallel combination of impedances-to-remote earth of all HV overhead ground wire-tower ladder networks only. The rest of the method still applies.

For LV line faults, assuming a radial LV line, a single fault infeed can be assumed if no generation exists on the load side of the line. This assumption is correct for most cases, but it should be pointed out that, for instance, a large induction motor can become a zero-sequence current generator at the instant of the fault, due to the inertia of the rotor and the mechanical load. If this can be neglected, the worst fault then occurs outside and near the station. The HV bus fault is modified by inserting, in series with Z_s , the self-impedance of the faulted phase conductor, and inserting, in series with Z_a , a faulted pole footing impedance. See Figure 3.

The methods described in this subclause should be used for hand calculation and estimation purposes only.

For a more complicated network, that is, the network with a high number of ROWs, circuits, transformers, ground sources, and short lines such as could be found between generating and switching stations, hand calculations cannot be used for either exact or approximate solutions; a computer program shall be used. In such a program, the theoretical approach should include the effect of other forms of grounding, such as rails, pipes, etc.; the effect of the length of lines; the effect of positive-sequence current phase shift in certain transformer windings; etc. For the theoretical basis of such a program, see [B24].

5.1.12 HV line-fault GPR

The theory shown in 5.1.10 is a simplified one. It can, however, be used with confidence to obtain results within some 10–30% of true figures, for estimating purposes.

The present topic is, by contrast, much more complicated not only by the complexity of the problem itself, but also by the vast amount of data input required. No hand calculation methods exist.

When a particular L-G HV bus fault current study indicates that the worst fault is the line fault from the HV bus in question, there is no easy way to determine the exact location of that fault. The only definite condition is that the fault will be at any one tower carrying circuit(s) connected to the bus at the same voltage level for which the aforementioned bus fault current study was produced. This necessitates placing a fault at each tower for *each* circuit of *each* tower line of *each* ROW carrying such circuit(s) and calculating the GPR at the station under study for each of these faults. Because of the tremendous multitude of line faults to be

examined (for complex stations with a number of ROWs and long lines, the number of faults to be examined may reach into the hundreds), to ask the planning section of the utility for so many fault current studies would be impractical. A selective computer program calculating GPR for line faults at all voltage levels shall contain its own short-circuit subprogram. *Both* positive-sequence and zero-sequence short-circuit current study sets will be required.

The system to be analyzed is modeled as a network consisting of left and right voltage sources with impedances between them. The faulted ROW is the path followed by the faulted circuit. A fault is defined to occur at a transmission tower between a left source and a right source. Ground currents will then flow through the grounding network made up of overhead ground wires, towers, counterpoises, and bond conductors. Because of inductive effects, all unfaulted circuits along the faulted ROW are also affected by the fault. The ground currents and the conductor currents are calculated using symmetrical components. This technique requires calculation or knowledge of the sequence impedances in the system under study. It is not within the scope of this standard to provide the basis for a computer program capable of doing this (see [B24]).

5.1.13 Example 1: HV bus fault and LV bus and line fault

5.1.13.1 System data

The station with Z_{SG} equal to 0.5Ω as shown in Figure 8 has three ROWs entering it.

- a) ROW 1 carries a single-circuit 230 kV transmission line with a conductor configuration as shown in Figure 7. The following data apply:
Conductor resistance and reactance data for 1 ft separation (0.305 m)
 - 1) Phase conductors: 1307.4 AS28/19
 $R + jX = 0.0797 + j0.3720 \Omega/\text{mi}$
Diameter: 1.34 in (34.0 mm)
 - 2) Overhead ground wires: 7 AWG No 8
 $R + jX = 2.354 + j6.44 \Omega/\text{mi}$ at 1 ft separation
Diameter: 0.385 in (9.8 mm)
The mutual impedance between ground wires is equal to $0.095 + j0.705 \Omega/\text{mi}$
 - 3) Tower footing impedance: 80Ω
 - 4) Earth resistivity: $1000 \Omega \cdot \text{m}$
 - 5) Average span: 1014 ft (309 m)
 - 6) Line length: 7 mi (11.3 km)
- b) ROW 2 data is the same as for ROW 1. Line length: 5 mi (8 km).
- c) ROW 3 carries a three-phase 44 kV delta-connected circuit. In Figures 8 and 9, two fault-current studies, one for the 230 kV and the other for the 44 kV bus, are shown. Both L-G and symmetrical fault currents were calculated. The future fault condition is assumed.

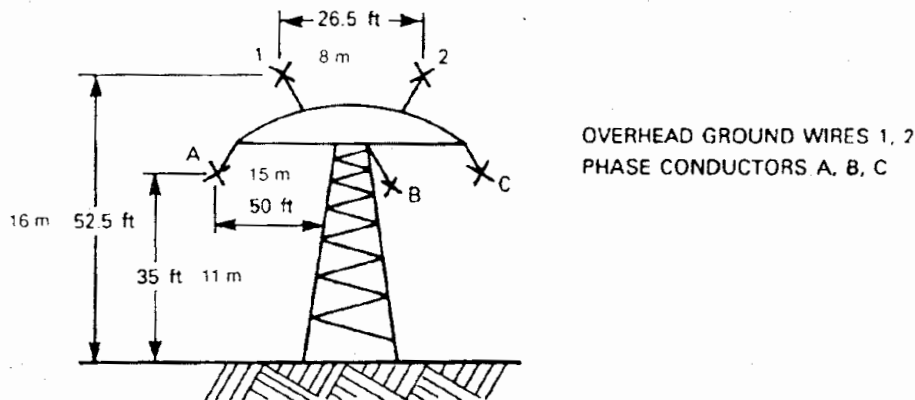
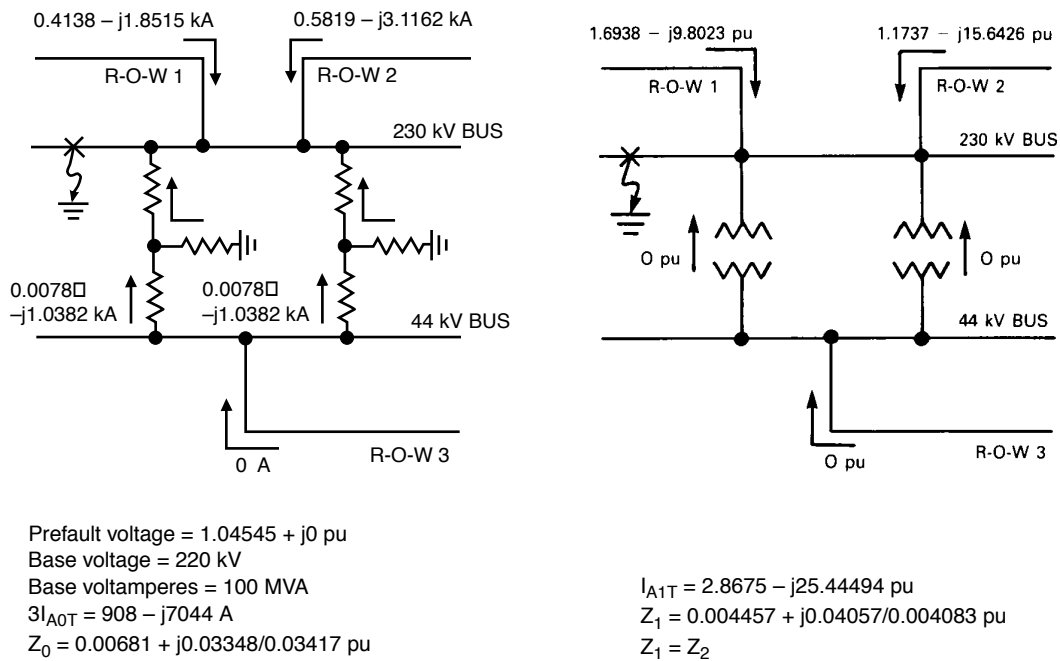

Figure 7—ROW 1 conductor configuration

5.1.13.2 Worst-fault location determination

In Figure 8a, note that in comparing the sum of all transmission and distribution line zero-sequence fault currents ($I = 995.7 - j4967.7$ A) and the sum of all local ground currents ($I = -15.6 - j2076.4$ A), the line current contribution is higher. This indicates that for GPR purposes, the bus fault is the worst case. In Figure 9a, all zero-sequence fault currents will originate from the local source, that is, the line fault will be the worst case.



(a) L-G fault

(b) Three-phase fault

Figure 8—230 kV bus fault

5.1.13.3 Worst-fault type

From Figures 8a and 8b, zero-sequence system reactance as seen from the fault terminal is X_0 equals 0.03348 pu, and the similar positive-sequence reactance is X_1 equals 0.04057 pu. A 2L-G fault will therefore produce higher zero-sequence fault currents than an L-G fault. However, as mentioned earlier, a 2L-G fault seldom evolves and so, for the purpose of this example, an L-G fault will be studied.

5.1.13.4 GPR calculations

5.1.13.4.1 230 kV bus fault

ROW 1

From Figure 8(a), the zero-sequence fault current contribution is

$$3I_{A0}(1)_1 = 413.8 - j1851.5 \text{ A}$$

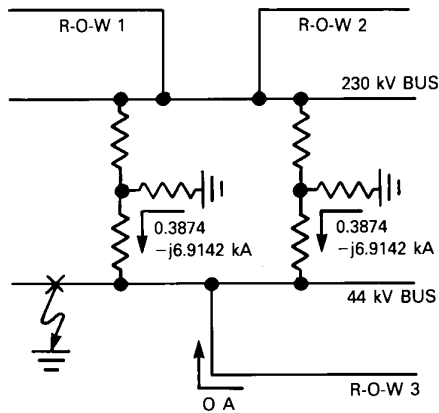

Prefault voltage = $1.0204 + j0$ pu
 Base voltage = 44.92 kV
 Base voltamperes = 100 MVA
 $3I_{A0T} = 775 - j13.828$ A
 $Z_0 = 0.00143 + j0.01602/0.01608$ pu

(a) L-G fault

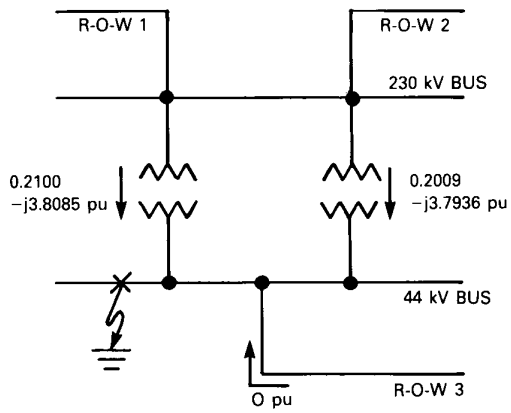

$I_{A1T} = 0.41091 - j7.6021$ pu
 $Z_1 = 0.00726 + j0.13431/0.13431$ pu
 $Z_1 = Z_2$

(b) Three-phase fault

Figure 9—44 kV bus fault

Total zero-sequence fault current is

$$3I_{A0T} = 980 - j7044 \text{ A}$$

Positive-sequence fault current contribution is

$$1I_{A1}(1)_1 = 1.694 - j9.802 \text{ pu}$$

based on a pre-fault voltage of

$$1.04545 + j0 \text{ (base voltage = 220 kV)}$$

The total positive-sequence fault current is

$$I_{A1T} = 2.87 - j25.44 \text{ pu}$$

The mutual impedances between each phase conductor and overhead ground wire 1 are

$$\text{Conductor A: } 0.0941 + j0.741 \text{ } \Omega/\text{mi}$$

$$\text{Conductor B: } 0.0941 + j0.736 \text{ } \Omega/\text{mi}$$

$$\text{Conductor C: } 0.0939 + j0.706 \text{ } \Omega/\text{mi}$$

Because of symmetry, the same mutual impedances apply to overhead ground wire 2 but in reverse order.

The self-impedances of overhead ground wires 1 and 2 are

Overhead ground wire 1: $2.448 + j1.748 \Omega/\text{mi}$

Overhead ground wire 2: $2.448 + j1.748 \Omega/\text{mi}$

Phase conductor currents [see Equations (5–7) and (12)]:

$$I_A(1)_1 = 13.060 + j287.362 \text{ A} \quad \text{Unfaulted phase}$$

$$I_B(1)_1 = 13.060 + j287.362 \text{ A} \quad \text{Unfaulted phase}$$

$$I_C(1)_1 = 387.681 - j2426.224 \text{ A} \quad \text{Faulted phase}$$

An intelligent choice of the faulted phase should be made to obtain the worst condition. Generally, the phase farthest from the overhead ground wire (or neutral) should be faulted. This implies a lower mutual impedance between the phase and neutral, causing lower shielding current in the neutral and forcing more current into the ground. Since phase C is faulted, the zero-sequence fault current, $I_C(1)_1$, flows in it toward this fault. Currents in the two unfaulted phases A and B are smaller and generally flow in the direction opposite to that of the faulted phase, that is, away from the fault, providing a shielding action and ultimately reducing the GPR. However, in some cases the reverse may be true, thereby producing antishielding. The induced overhead ground wire currents are calculated as shown in Equation (18).

$$I_{SK}(1)_1 = -224.57 + j222.288 \text{ A}$$

$$I_{SK}(2)_1 = -336.383 + j248.635 \text{ A}$$

where

$I_{SK}(1)_1$ is the induced current in the overhead ground wire, circuit 1, ROW 1;

$I_{SK}(2)_1$ is the induced current in the overhead ground wire, circuit 2, ROW 1.

Since the induced overhead ground wire current flows in the direction opposite to that of the faulted phase, it provides shielding action as well. The ratio of overhead ground wire to line current (shielding factor) is calculated as $(-0.030904 - j0.024471)$.

Inequality [Equation (20)] shows that the line becomes electrically infinite after the 31st span. Therefore, Equation (21) can be used and will result in a overhead ground wire/tower ladder network impedance for circuit 1 of $Z_\infty(1)$ of

$$Z_\infty(1) = 4.9536 + j2.0716 \Omega$$

This value is conservative because of the shorter line length.

ROW 2

Similar to ROW 1 calculations:

$$3I_{A0}(1)_2 = 581.9 - j3116.2 \text{ A}$$

$$I_{A1}(1)_2 = 1.774 - j15.64 \text{ pu}$$

Mutual impedances between each phase conductor and overhead ground wires 1 and 2 are the same for ROW 1. The same is true for the $Z_{\infty}(2)$, the network impedance for circuit 2. Phase conductor currents are calculated as

$$I_A(1)_2 = -7.919 - j404.735 \text{ A}$$

$$I_B(1)_2 = -7.919 + j404.735 \text{ A}$$

$$I_C(1)_2 = 597.737 - j3925.671 \text{ A}$$

The induced overhead ground wire currents are

$$I_{SK}(1)_2 = -398.117 + j390.386 \text{ A}$$

$$I_{SK}(1)_2 = -544.745 + j432.182 \text{ A}$$

The ratio of overhead ground wire to line current is $-0.30967 - j0.24474$, and the number of spans required for the electrically infinite overhead ground wire/tower ladder network is 31. The residual fault current, I_{GPR} [see Equation (22)], can be shown to be

$$I_{GPR} = -528.12 - j3674.21 \text{ A}$$

The GPR [see Equation (24)] will be 1580.88 V, where Z_{GPR} is equal to $0.43 + j0.03 \Omega$, calculated with Z_{SG} equal to 0.5Ω .

5.1.13.4.2 44 kV bus fault

For all of the 44 kV bus faults, $3I_{A0T}$ is generated locally, resulting in a negligible GPR.

5.1.13.4.3 44 kV line fault

Because ROW 3 carries a three-wire (no neutral) circuit, the circuit in Figure 10 can be used to calculate the 44 kV line fault as follows:

- a) The prefault voltage (V_p) is 46 000 V.
- b) The 44 kV line zero-sequence current contribution (see Figure 10a) is $3I_{A0}(1)_3$ equals 0 A.

The low-side (LS) transformer contribution, I_T , is $855 - j16\,911$ A. The total LS fault current is $3I_{A0T} = 855 - j16\,911$ A; and the 230 kV zero-sequence current contribution, I_N , is 0 A. The system impedance at the faulted 44 kV (bus) terminal, Z_S , is $0.11 + j1.91 \Omega$. The calculated LS line fault GPR, which takes into account the impedance of the line up to the point of the fault, is 5620.64 V. As a matter of interest, the fault impedance, Z_a (see Figure 3), of 5Ω will reduce the GPR to 1929.2 V and illustrates the need to include the appropriate value of the fault impedance in some cases.

5.1.14 Example 2: HV line fault

5.1.14.1 System data

The generating station (Figure 10) has three voltage levels:

- a) ROW 1 has a tower line carrying a single 230 kV circuit with 795.0 ACSR 26/7 conductors and two 3/8 in (9.5 mm) steel overhead ground wires. The tower-footing impedance is 79.57Ω , and the average span is 924 ft (282 m). Earth resistivity, assumed to be uniform, is $1000 \Omega\cdot\text{m}$.

- b) ROW 2 has tower lines carrying four 230 kV circuits with 795.0 ACSR 26/7 conductors and four 3/8 in (9.5 mm) steel overhead ground wires. The average span and the earth resistivity are the same as in ROW 1.
- c) The 44 kV bus is connected to the 230 kV bus by means of a delta grounded wye-connected transformer. A three-wire (no neutral) 44 kV circuit is on ROW 3.
- d) 13.8 kV is the generation voltage level.

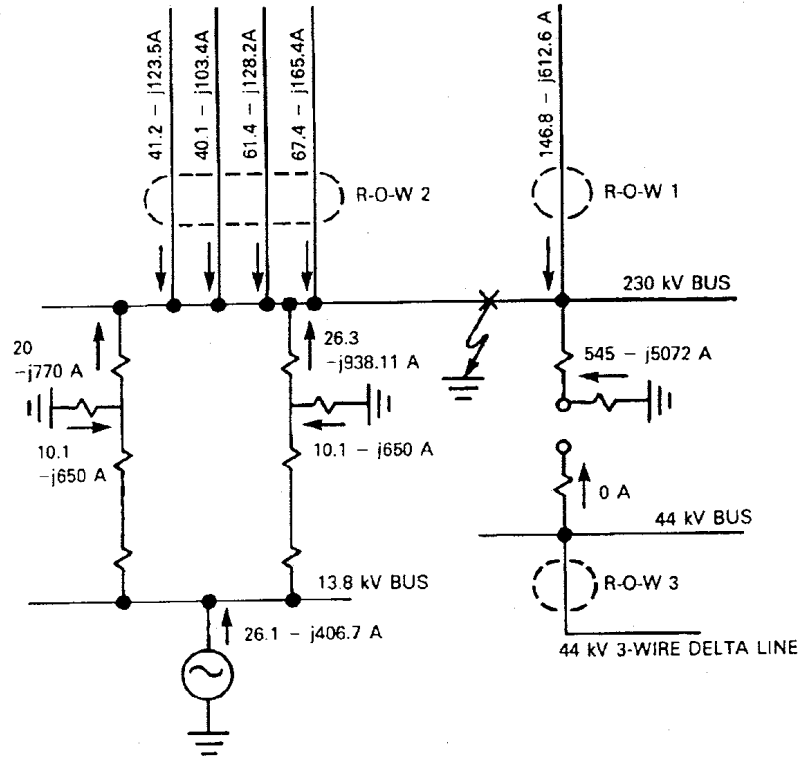

Prefault voltage = $1.04545 + j0$ pu
 Base voltage = 220 kV
 $3I_{A0T} = 948 - j8714$ A
 $Z_0 = 0.00295 + j0.02518/0.02555$ pu

(a) L-G fault

Figure 10—230 kV bus fault

5.1.14.2 Worst-fault location determination

- a) 230 kV fault. In Figure 10a, the vectorial sum of all transmission and distribution line contributions for the 230 kV bus fault is I_L .

$$I_L = \sum_r \sum_j (3I_{A0}(J)_r) = 3I_{A0T} = 356.9 - j1133.3 \text{ A}$$

Local ground sources contribute $I_T = 591.1 - j7580.7$ A.

Because I_T is greater than I_L , the greatest GPR will be caused by a fault occurring along one of the four HV lines. The 230 kV bus fault will produce less GPR than the line fault.

- b) *44 kV fault.* As seen in Figure 10a, the station 230/44 kV transformer has a delta-connected secondary. Assuming a delta-connected primary at the station to which the 44 kV line is connected (at the other end), zero-sequence fault currents are negligible. The only impedance-to-ground is due to capacitive coupling, that is, line charging currents will flow, which implies that both 44 kV bus and line faults will produce an insignificant GPR at the station under study.
- c) *13.8 kV fault.* Essentially all the 13.8 kV fault current generated circulates locally; therefore, no appreciable GPR will be developed due to the L-G fault at the generator terminals.

5.1.14.3 Worst-fault type

In Figures 10a and 10b, for the 230 kV faults, the positive-sequence system reactance as seen from the fault terminals is X_1 equals 0.03408 pu and zero-sequence reactance is X_0 equals 0.02518 pu.

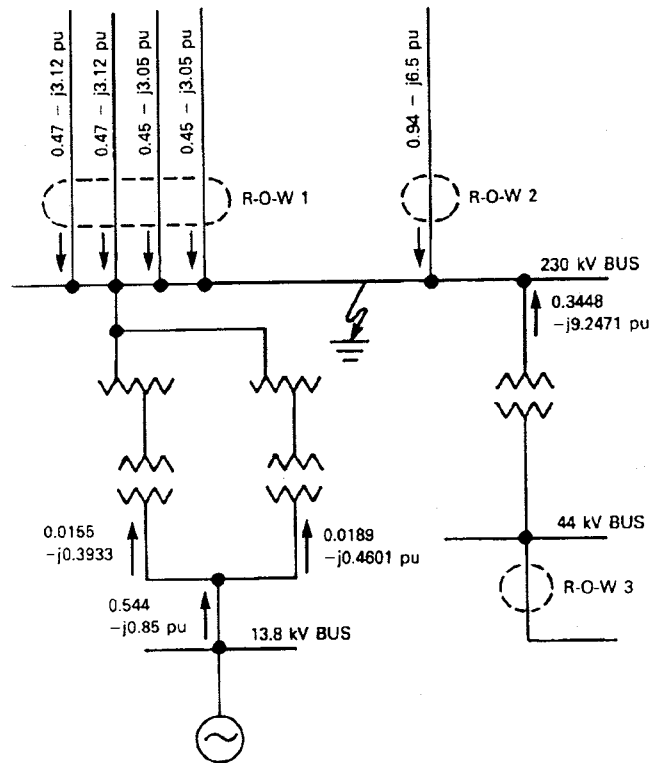

$$I_{A1T} = 3.21757 - j20.35081 \text{ pu}$$

$$Z_1 = 0.00362 + j0.03400 / 0.03428 \text{ pu}$$

$$Z_1 = Z_2$$

(b) Three-phase fault

Figure 10—230 kV bus fault

Because X_1 is greater than X_0 , a 2L-G fault will cause a higher zero-sequence fault current, resulting in a greater GPR than a single L-G fault. However, this example is limited to a single L-G fault.

5.1.14.4 GPR calculations

As mentioned in 5.1.11, this calculation is complex and will not be shown here.

A sample of a computer program output is shown in Table 2.

Left station GPR versus tower number, as counted from the left station, is shown in Figure 11 and is seen peaking for the fault occurring on the 30th tower out of the left station, at 2216.965 V.

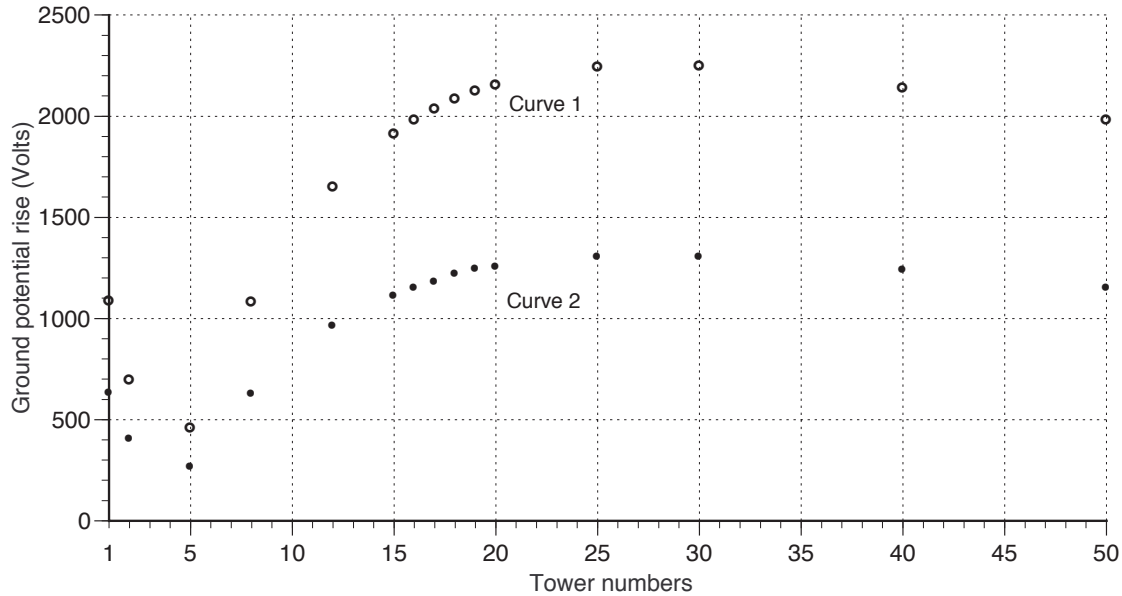

Curves 1 and 2 correspond to the following left and right grid resistance values (RGL, RGR):

| | RGL | RGR |
|---------|----------------|----------------|
| Curve 1 | 1.000 Ω | 1.000 Ω |
| Curve 2 | 0.500 Ω | 0.500 Ω |

Maximum GPR (2216.965 V) peaks for the fault occurring on the 30th tower out of the left station.

Figure 11—Left station potential versus tower numbers

5.2 Duration of the fault and its relationship to wire-line telecommunication requirements for power system protection

The duration of the fault currents and resulting interfering voltages depends upon the power system protective relay scheme and its equipment, as well as the power system layout and equipment. The relaying schemes often employ wire-line telecommunication facilities.

5.2.1 Time required to clear a fault

The time required to clear a fault usually falls into one of the following categories:

- Surge arresters.* Lightning surges that are cleared by arresters on the power circuits in less than half a cycle require no circuit breakers to open and no fuses to melt. When rapid clearing takes place, no power system telecommunication is necessary to clear this fault.

Table 2—Sample computer program output

| From Left Station (Tower) | Left station ground resistance (L Res) (Ω) | Right station ground resistance (R Res) (Ω) | Ground current from left station (L I_g) (A) | Ground current from right station (R I_g) (A) | Skywire current from left (Max L I_{skwire}) (A) | Skywire current from right (Max R I_{skwire}) (A) | Faulted tower current from left (I_{T1}) (A) | Faulted tower current from right (I_{T2}) (A) |
|---------------------------|---|--|---|--|---|--|--|---|
| 1 | 1.000 | 1.000 | 1057.450 | 435.603 | 3355.020 | 391.797 | 69.018 | 0.000 |
| 1 | 0.500 | 0.500 | 1230.460 | 506.631 | 3392.419 | 356.077 | 63.996 | 0.000 |
| 2 | 1.000 | 1.000 | 667.482 | 443.967 | 3095.051 | 591.347 | 109.798 | 0.000 |
| 2 | 0.500 | 0.500 | 776.396 | 516.409 | 3100.512 | 566.984 | 106.911 | 0.000 |
| 5 | 1.000 | 1.000 | 426.452 | 468.129 | 2510.236 | 380.940 | 190.726 | 0.000 |
| 5 | 0.500 | 0.500 | 496.037 | 544.514 | 2505.393 | 985.201 | 191.699 | 0.000 |
| 8 | 1.000 | 1.000 | 1050.195 | 491.035 | 2166.461 | 1135.743 | 232.181 | 0.000 |
| 8 | 0.500 | 0.500 | 1221.556 | 571.159 | 2154.902 | 1196.713 | 234.482 | 0.000 |
| 12 | 1.000 | 1.000 | 1617.079 | 519.809 | 1901.428 | 1300.497 | 255.396 | 0.000 |
| 12 | 0.500 | 0.500 | 1890.932 | 604.719 | 1999.775 | 1912.195 | 257.842 | 0.000 |
| 15 | 1.000 | 1.000 | 1882.202 | 540.435 | 1779.510 | 1325.923 | 260.495 | 0.000 |
| 15 | 0.500 | 0.500 | 2189.322 | 628.618 | 1769.961 | 1335.929 | 262.598 | 0.000 |
| 16 | 1.000 | 1.000 | 1947.792 | 547.099 | 1747.486 | 1327.927 | 260.978 | 0.000 |
| 16 | 0.500 | 0.500 | 2265.602 | 636.369 | 1738.723 | 1337.254 | 262.841 | 0.000 |
| 17 | 1.000 | 1.000 | 2003.913 | 553.674 | 1719.599 | 1327.717 | 260.903 | 0.000 |
| 17 | 0.500 | 0.500 | 2330.892 | 664.020 | 1710.607 | 1336.331 | 262.623 | 0.000 |
| 18 | 1.000 | 1.000 | 2051.594 | 560.172 | 1692.302 | 1325.706 | 260.361 | 0.000 |
| 18 | 0.500 | 0.500 | 2406.354 | 651.575 | 1685.076 | 1333.620 | 262.038 | 0.000 |
| 19 | 1.000 | 1.000 | 2091.729 | 566.599 | 1669.200 | 1322.265 | 259.625 | 0.000 |
| 19 | 0.500 | 0.500 | 2453.036 | 659.039 | 1661.694 | 1329.450 | 261.162 | 0.000 |
| 20 | 1.000 | 1.000 | 2125.121 | 572.929 | 1645.937 | 1317.691 | 259.656 | 0.000 |
| 20 | 0.500 | 0.500 | 2471.879 | 666.414 | 1640.106 | 1924.270 | 260.059 | 0.000 |
| 25 | 1.000 | 1.000 | 2214.006 | 603.607 | 1553.872 | 1294.921 | 251.747 | 0.000 |
| 25 | 0.500 | 0.500 | 2575.266 | 702.099 | 1550.695 | 1239.795 | 252.599 | 0.000 |

Table 2—Sample computer program output (continued)

| From Left Station (Tower) | Left station ground resistance (L Res) (Ω) | Right station ground resistance (R Res) (Ω) | Ground current from left station ($L I_g$) (A) | Ground current from right station ($R I_g$) (A) | Skywire current from left (Max L I_{skwire}) (A) | Skywire current from right (Max R I_{skwire}) (A) | Faulted tower current from left (I_{T1}) (A) | Faulted tower current from right (I_{T2}) (A) |
|---------------------------|---|--|--|---|---|--|--|---|
| 30 | 1.000 | 1.000 | 2216.965 | 632.829 | 1481.320 | 1246.225 | 242.571 | 0.000 |
| 30 | 0.500 | 0.500 | 2579.709 | 736.098 | 1479.725 | 1249.349 | 244.045 | 0.000 |
| 40 | 1.000 | 1.000 | 2106.869 | 689.022 | 1366.106 | 1172.829 | 227.924 | 0.000 |
| 40 | 0.500 | 0.500 | 2450.647 | 800.297 | 1365.807 | 1173.363 | 228.056 | 0.000 |
| 50 | 1.000 | 1.000 | 1949.651 | 740.318 | 1275.204 | 1111.865 | 214.742 | 0.000 |
| 50 | 0.500 | 0.500 | 2267.777 | 861.117 | 1275.202 | 1111.958 | 214.771 | 0.000 |

b) *Fuse/circuit breakers.* The voltage breakdown of power system insulation requires circuit breakers to open or fuses to melt. The fault can be cleared in one of the following ways:

- 1) Normal operation for all voltage classes when the fault clearing time is from 0.03–3.0 s or more. Signals transmitted by wire-line facilities are often used to trip breakers to attain a clearing time interval of 0.03–0.15 s.
- 2) Abnormal operation occurs when fault clearing time is increased due to a failure of some switching equipment or its control. Wire-line facilities are often used as part of this backup tripping scheme, with or without being a part of the normal tripping. The maximum time is rarely, if ever, over 3 s in situations having a high GPR. An uninterruptible wire-line facility is essential in this type of operation.
- 3) On distribution lines protected by single-phase reclosers, sectionalizers, or some combination thereof, one or two phases may become open following a ground fault while the remaining phase(s) is (are) still operating, causing a small ground current to flow. This condition is not easy to recognize and may, consequently, take several hours to clear.

5.2.2 Decay time

The calculation of the fault currents and interfering voltage should include their changes or decay time for the duration of the fault as expected from the normal tripping time, or abnormal tripping time, if backup protection involves wire-line telecommunication facilities. In some limited cases, the telecommunication channel can be discontinued momentarily after the tripping signals have been received.³ There are types of relay protection (for example, phase comparison) that shall have continuous telecommunications prior to, during, and as long as the fault exists.

5.3 Extraordinary possibilities

5.3.1 Double phase-to-ground fault

There is a rare possibility that a single phase-to-ground fault may develop into a double phase-to-ground fault at the critical instant necessary to yield the worst-case GPR.

³See A5.2.5 in IEEE Std 487-1992 for cautions concerning personnel safety.

5.3.2 Transmission lines

In many locations, a transmission line having a higher voltage than exists in the substation being studied is nearby. Should this external source of high voltage be applied to the substation, the normal fault current and resulting GPR may be exceeded.

5.3.3 Telluric currents

Telluric currents are composite, sinusoidal, very slowly varying earth currents. The magnitudes and phase relationships vary with time. The fundamental frequency period is in the order of minutes, and there are resonant peaks as high as 8 Hz, 14 Hz, and 21 Hz. At frequencies above 2 Hz, the current amplitudes are small.

The electric current system of the earth varies from 3600–6500 A with polarity, daily, and seasonal variations as well. There are several contributing factors to these current levels that are beyond the scope of this recommended practice and generally apply to latitudes above 50° north. About three-fourths of the variations in the magnetic field of the earth is produced outside the earth. The cause of this variable is found in the electric currents in the upper atmosphere, 50–200 mi (80–325 km) above the surface of the earth. These currents vary from 30 000–80 000 A and cause a wide variation in the earth currents.

5.3.4 Magnetic storms

Usually following severe sunspot activities, the magnitude of the currents in the atmosphere of the earth increases. As a result, the level of the electric currents on the earth are drastically increased; however, the overall cycle from minimum to maximum levels takes over 20 years. Previous technical publications have shown that these GIC have seriously affected power system operations. However, little is known, or published, regarding their effects on GPR or LI voltages into wire-line telecommunication facilities.

In any event, since the surface potential of the earth can be 6 V/km or even higher, currents will flow in power or telecommunication systems that are grounded at intervals that are remote from one to the other. Thus, under the most severe conditions, both the GPR and the induced voltage can be higher than normal.

In areas where large telluric currents are known to exist or where GIC are high, or both, evaluate the resultant potentials and their impact on probability factors in determining maximum values of GPR and LI voltages.

5.3.5 Multiple faults

There are combinations of circumstances and multiple faults that will produce currents and voltages higher than those calculated on a single contingency basis.

5.4 Example of a GPR calculation and volt time area calculation

The following is an example of a GPR calculation with the power system having a phase-to-phase voltage of 115 kV and an arrangement shown in Figure 1a and described in item a) of 5.1.6. For simplicity, only that portion of the fault current that creates GPR is considered in the calculations, and the contribution of fault current from the local source is not considered. No overhead ground wires are assumed in this example. The equivalent remote ground source fault impedance and the line fault impedance is given in per unit (pu) on a 100 MVA three-phase base. The local source station ground grid impedance is given as 1.5 Ω.

5.4.1 Impedance of power system

Source $Z_1 = 0.01 + j0.05$ pu on a 100 MVA base
 $Z_2 = 0.01 + j0.05$ pu on a 100 MVA base

$Z_0 = 0.02 + j0.08$ pu on a 100 MVA base zero-sequence impedance of the complete fault loop, including source impedance

Line $Z_1 = 0.03 + j0.19$ pu on a 100 MVA base
 $Z_2 = 0.03 + j0.19$ pu on a 100 MVA base
 $Z_0 = 0.18 + j0.67$ pu on a 100 MVA base

Station ground grid impedance (Z_{SG}) = 1.5 Ω

$$\text{base } \Omega = \frac{115^2}{100} = 132.25$$

$$Z_{SG} = \frac{1.5}{132.25} = 0.011342 \text{ pu}$$

The value to be inserted in the sequence network is 3×0.011342 or 0.034 pu.

Therefore,

$$Z_{TOT} = Z_1 + Z_2 + Z_0 + 3(Z_{SG} + Z_{ARC}) = 0.314 + j1.23 \text{ pu}$$

where

Z_{TOT} is the total impedance of the power system;

Z_{ARC} is the arc impedance.

NOTE—In this case, Z_{ARC} equals 0 (i.e., bolted fault).

5.4.2 Calculations to be performed

- a) Calculate the peak current for phase-to-ground fault at 115 kV in the substation yard (see 5.4.3).
- b) Calculate the area under the current curve as illustrated for the interval to the first zero crossing (see 5.4.4).
- c) Calculate the GPR and the voltage curve area (see 5.4.5).
- d) Calculate the peak current for a single phase-to-ground fault followed by a double phase-to-ground fault (see 5.4.6).
- e) Calculate the area under the current curve to the first zero crossing (see 5.4.7).
- f) Calculate the GPR and the voltage curve area (see 5.4.8).

NOTE—For the general case, only that portion of the total fault current returning through the substation ground grid impedance with respect to reference ground should be considered.

5.4.3 Calculating peak current [see item a) of 5.4.2]

The base current for a 100 MVA, 115 kV transformer bank is 502 A per phase. The symmetrical fault current in the one faulted phase and ground, assuming no change in the source impedance with time and with the substation ground grid impedance included, is three times the base current divided by $Z_1 + Z_2 + Z_0 + 3Z_{SG}$.

$$I_G = \frac{3(502)}{0.314 + j1.23} = \frac{1506}{1.269 \angle 75.68} = 1186 \angle -75.68 \text{ A rms steady-state}$$

The peak of the steady-state current is $\sqrt{2}(1186) = 1677$ A . This fault current lags its corresponding phase voltage by 75.68° . When the voltage is approaching zero and is only 14.32° away, the current will be at maximum. If a phase-to-ground fault occurs at that instant, then there will be a dc offset equal to 1677 A and of opposite polarity. The net current will be zero, assuming no pre-fault current. The dc offset will decrease exponentially from this instant with no change in polarity. When the alternating current has reversed its polarity, and approximately one-half cycle later, the total fault current will be maximum.

$$i = i_{ac} + i_{dc} = I \left[\sin(\omega t + \phi - \theta) - e^{-\frac{(Rt)}{L}} \sin(\phi - \theta) \right] \quad (24a)$$

where

- ϕ is the initial emf phase at the instant of fault;
- θ is the power factor angle;
- i is the instantaneous total fault current;
- i_{ac} is the ac component of the asymmetrical fault current;
- i_{dc} is the dc component of the asymmetrical fault current;
- I is the peak symmetrical current (1677 A);
- t is the time from start of fault, or $t = 0$ is 90° before i is zero (at maximum current $t = 0.00833$ s).

NOTE— X/R equals $\tan 75.68^\circ$, or

$$X/R = \frac{1.23}{0.134} = 3.9171$$

where

- R is the resistance of the system to the point of fault
- X is the reactance of the system to the point of fault

Assuming $\phi - \theta = -\frac{\pi}{2}$

then

$$i = i_{ac} + i_{dc} = I \left[\sin\left(377t - \frac{\pi}{2}\right) + e^{-\left(\frac{t}{T}\right)} \right]$$

where

T is the time constant $= \frac{X}{377R}$ for 60 Hz = 0.01039

At peak,

$$i_{ac} = 1677 \sin [377(0.004167)] = 1677 \sin 1.57 = 1677 \text{ A}$$

At one-half cycle after the fault starts,

$$i_{ac} = 1677 \sin [377(0.008333 - 0.004167)] = 1677 \text{ A}$$

$$i_{dc} = 1677 e^{\left(\frac{-0.008333}{0.01039}\right)} = 1677(0.44842) = 752 \text{ A}$$

$$i = 1677 + 752 = 2429 \text{ A}_{\text{peak}}$$

5.4.4 Calculating the area [see item b) of 5.4.2]

The area under the current waveform may be of importance for iron core devices since the flux reversal is delayed to give the effect of a lower frequency. This area can be calculated as the sum of three parts: the dc offset, the sine wave above the axis, and the sine wave below the axis. The time between zero crossings of the total fault current is the time between the start of the fault and the next time that i_{dc} is equal to $-i_{ac}$ and is best determined by trial and error.

5.4.4.1 Area No. 1

Let the ac wave be given by the equation

$$i_{ac} = -I \cos 377t$$

where the angle $377t$ is given in radians. Then at $t = 0$, the current is maximum and is negative.

At the first ac current zero crossing, $t = 0.004167$.

$$i_{ac} = -I \cos(1.5708) = -I \cos 90^\circ = 0$$

but

$$i_{dc} = I e^{\left(\frac{-t}{T}\right)} = I e^{\left(\frac{-0.004167}{0.01039}\right)} = I e^{-0.40103} = I(0.670) \text{ (assumed to be positive)}$$

At the second ac zero crossing,

$$i_{ac} = -I \cos 377(0.0125) = -I \cos 4.7125 = -I \cos 270^\circ = 0$$

but

$$i_{dc} = I e^{\left(\frac{-0.0125}{0.01039}\right)} = I e^{-1.203} = I(0.300)$$

At $t = 0.01325095$, the ac and the dc currents are equal and opposite.

$$i_{ac} = -I \cos 377t = -I \cos 4.9956 = -I(0.27932)$$

$$i_{dc} = I e^{\left(\frac{-0.01325095}{0.01039}\right)} = I e^{-1.275356} = +I(0.27932)$$

$$\text{Area No. 1} = I \int_0^{t_1} e^{\left(\frac{-t}{T}\right)} dt = I \left[-T e^{\frac{-t}{T}} \right]_0^{t_1} = 1677 [0.01039(1 - 0.27932)] = 12.56 \text{ A}\cdot\text{s}$$

where

$$t_1 = 0.01325095;$$

$$T = 0.01039 \text{ (see Figure 12).}$$

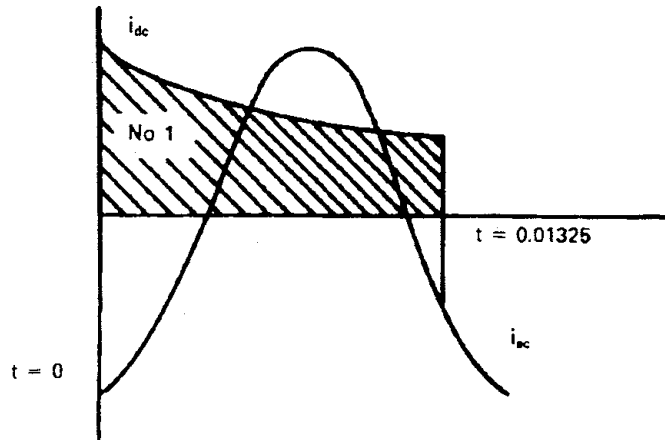

Figure 12—Current curve and determination of Area No. 1

5.4.4.2 Area No. 2

$$\text{Area No. 2} = I \int_0^{\frac{\pi}{2}} \sin 377t dt = \frac{I}{377} [-\cos 377t]_0^{0.004167} = \frac{1677}{377} [(\cos 90^\circ) - 1] = 4.448 \text{ A}\cdot\text{s}$$

(See Figure 13.)

5.4.4.2 Area No. 3

For Area No. 3, the time is $t = 0.01325095 - 0.0125$.

$$\text{Area No. 3} = -\frac{1677}{377} [-\cos 377t]_0^{0.00075095} = 4.448(\cos 0.23311 - 1) = 0.1771$$

(See Figure 14.)

5.4.4.3 Total area

$$\text{Total area} = (12.56 + 4.448 - 0.177) = 16.83 \text{ A}\cdot\text{s}$$

The normal one-half cycle area is twice Area No. 2, which equals 8.896 A·s.

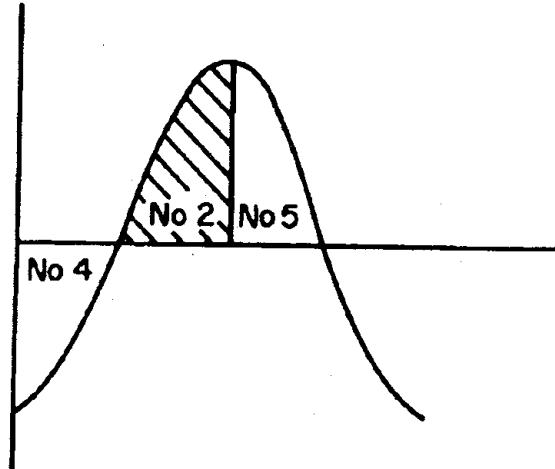

Figure 13—Current curve and determination of Area No. 2

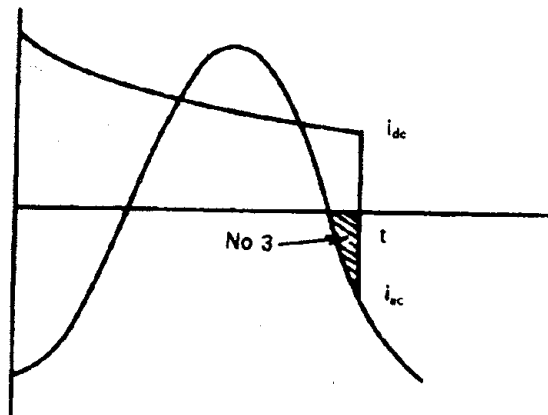

Figure 14—Current curve and determination of Area No. 3

5.4.4.4 Areas No. 4 and No. 5

Areas No. 4 and No. 5 cancel each other.

5.4.5 Calculating GPR and voltage curve area [see item c) of 5.4.2]

The resultant GPR based on the peak currents (see 5.4.3) will be

- $[1.5 \Omega \text{ (station ground grid impedance)}] (1186 \text{ A})$ is equal to $1779 \text{ V}_{\text{rms}}$ symmetrical
- $\sqrt{2} (1779 \text{ V}) = 2515 \text{ V}_{\text{peak}}$ symmetrical
- $1.5 (2429 \text{ A}) = 3643 \text{ V}_{\text{peak}}$ with dc offset

5.4.6 Calculating peak current [see item d) of 5.4.2]

Calculating peak current will be done for a single phase-to-ground fault followed by a double phase-to-ground fault.

NOTE—Calculations are rounded off to two significant decimal places.

It is first necessary to determine the steady-state double phase-to-ground fault involving phases B and C, with phase A as the reference for angles.

$$I_0 = \frac{-Z_2(502)\angle 0^\circ}{Z_0Z_1 + Z_2Z_1 + Z_0Z_2} = \frac{0.2433\angle 80.53^\circ (502)\angle 180^\circ}{0.4410\angle 154.26^\circ} = 277\angle 106.27^\circ$$

$$I_1 = \frac{(Z_0 + Z_2)(502)\angle 0^\circ}{0.4410\angle 154.26^\circ} = \frac{1.027\angle 74.53^\circ (502)\angle 0^\circ}{0.4410\angle 154.26^\circ} = 1169\angle 280.27^\circ$$

$$I_2 = \frac{-Z_0(502)\angle 0^\circ}{0.4410\angle 154.26^\circ} = \frac{0.7857\angle 72.67^\circ (502)\angle 180^\circ}{0.4410\angle 154.26^\circ} = 894\angle 92.42^\circ$$

$$I_B = I_0 + 1\angle 240^\circ I_1 + 1\angle 120^\circ I_2 = 1882\angle 176.81^\circ \text{ A rms symmetrical} = 2662 \text{ A peak}$$

$$I_C = I_0 + 1\angle 120^\circ I_1 + 1\angle 240^\circ I_2 = 1786\angle 22.85^\circ \text{ A rms symmetrical} = 2626 \text{ A peak}$$

$$I_G = 3I_0 = I_B + I_C = 831\angle 106.27^\circ \text{ A in ground}$$

The angle between I_B and I_C is 153.96° .

Should the initial fault be phase B to ground at the time that yields the maximum dc offset, and then followed by a phase C involvement after 0.007128 s or the time phase B travels 153.96° , the result can be as shown in Figure 15.

NOTE—For simplicity of representation, the old $I_{B_{ac}}$ is considered to be in phase with the new $I_{B_{ac}}$. The dc decrement of phase B until the start of phase C fault is calculated first.

$$\frac{t}{T_B} = \frac{0.007128}{0.01039} = 0.686$$

and

$$e^{-0.686} = 0.5036$$

then

$$i_{B_{dc}} = 1677 (0.5036) = 845 \text{ A}$$

The ac component of phase B when phase C starts is

$$-1677 \cos 153.96 = 1507 \text{ A}$$

Then the total phase B current is

$$845 + 1507 = 2352 \text{ A}$$

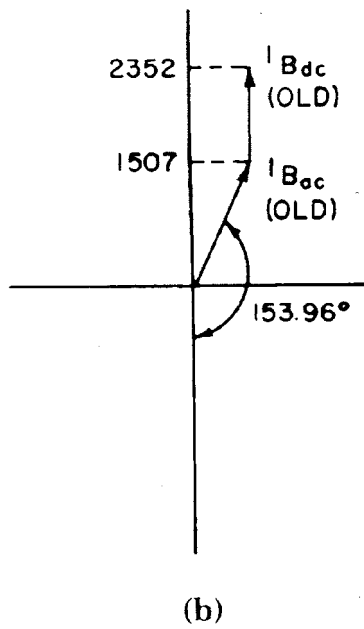
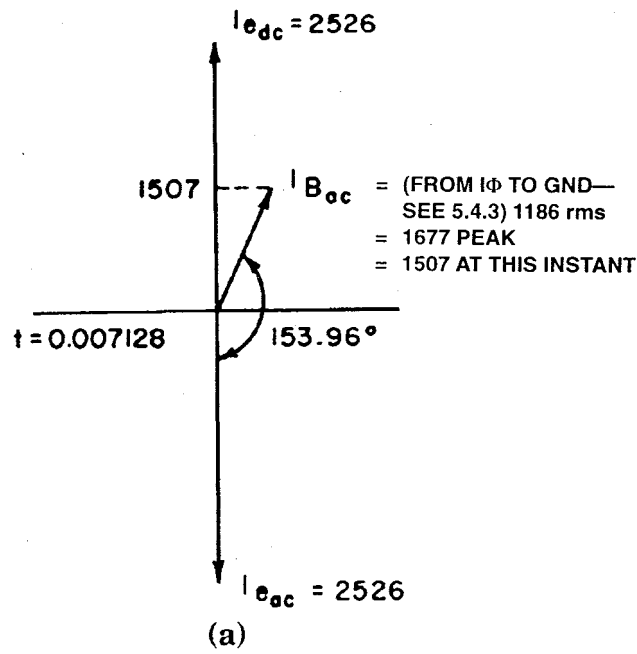

Figure 15—Graphical representations of peak currents

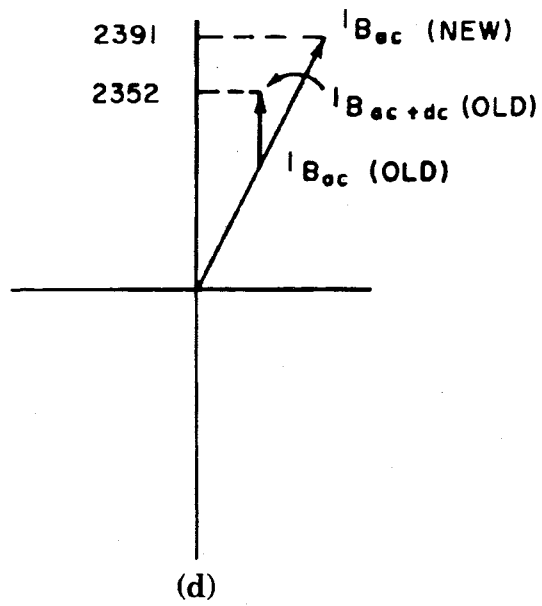
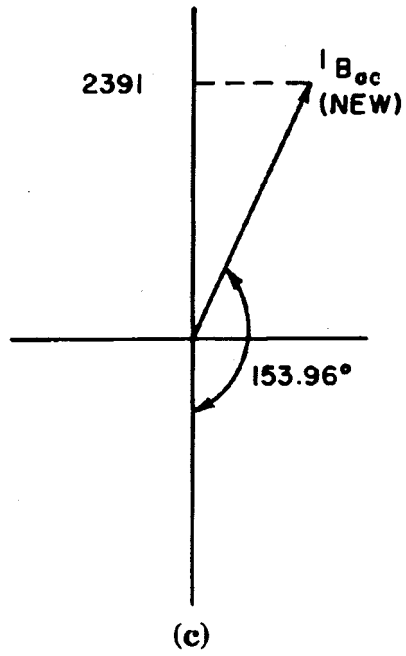

Figure 15—Graphical representations of peak currents (continued)

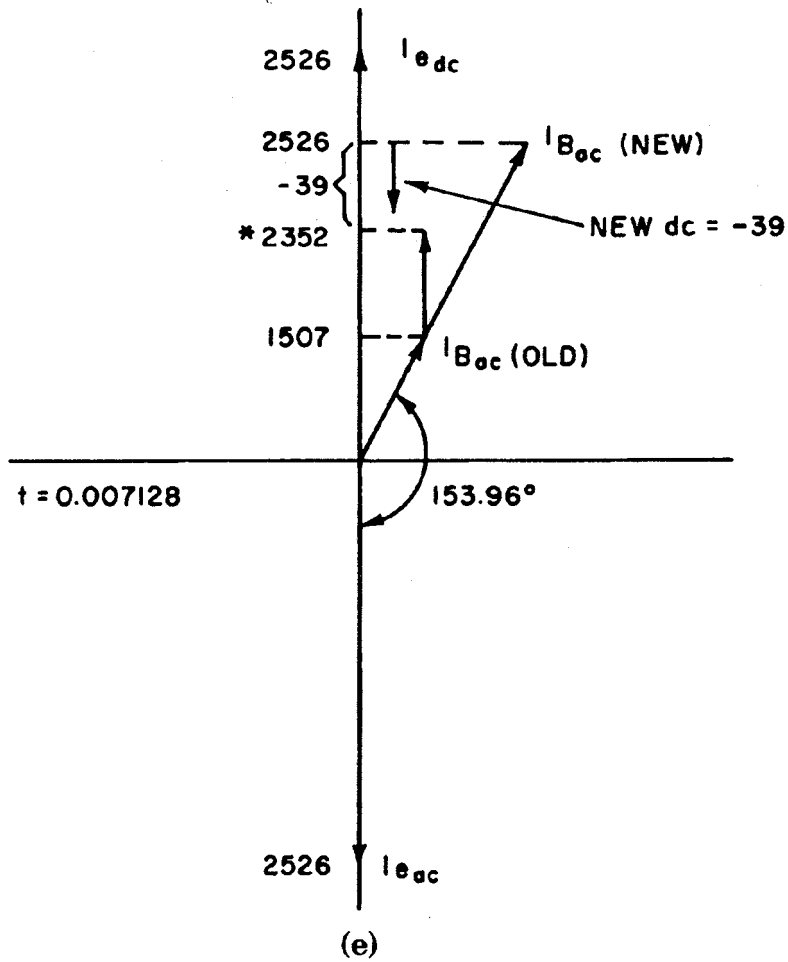

Figure 15—Graphical representations of peak currents (continued)

From the double phase-to-ground calculation, phase B should be

$$(\sqrt{2})(1882)\cos(153.96) = 2391$$

when phase C is at maximum, but it is actually 2352. Therefore, the new phase, B_{dc} component is -39 . To obtain its decrement, evaluate the X/R ratio for the new phase B current using the angle between E_B and I_B (where E is the fault voltage):

$$\tan(240^\circ - 176.81^\circ) = \tan 63.19^\circ = 1.979$$

then

$$T_B = \frac{1.979}{377} = 0.0052488$$

The X/R ratio for phase C is determined by the angle between E_C and I_C :

$$\tan(120^\circ - 22.85^\circ) = \tan 97.15 = 7.9718$$

then

$$T_C = \frac{7.9718}{377} = 0.021145$$

Through trial and error, the maximum ground current for this problem appears after I_B and I_C have rotated 85° or at 0.0039356 s after their position when I_C started.

To determine the total fault current, evaluate the two components of each phase current (see Figure 16).

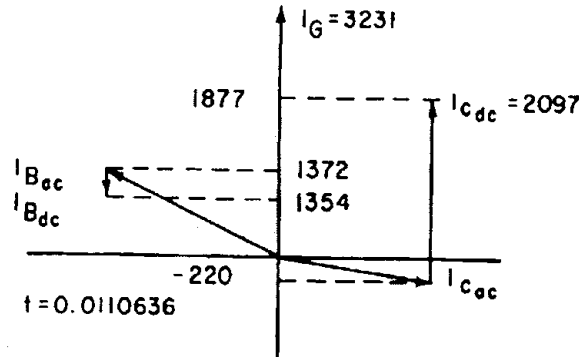

Figure 16—Graphical representation for arriving at total fault current

$$I_{C_{ac}} \text{ component} = 2526 \sin(-90^\circ + 85^\circ) = -220 \text{ A}$$

For the $I_{C_{dc}}$ component, find

$$\frac{t}{T_C} = \frac{0.0039356}{0.021145} = 0.18612$$

then

$$e^{-0.18612} = 0.8302$$

and

$$I_{C_{dc}} = 2526(0.8302) = 2097 \text{ A}$$

$$\text{total } I_C = 2097 - 200 = 1877 \text{ A}$$

$$I_{B_{ac}} = 2662 \sin(153.96^\circ - 5.0^\circ) = 1372 \text{ A}$$

For the $I_{B_{dc}}$ component, find

$$\frac{t}{T_B} = \frac{0.0039356}{0.0052488} = 0.74981$$

then

$$e^{-0.74981} = 0.4725$$

and

$$I_{B_{dc}} = 0.4726(-39) = -18 \text{ A}$$

$$\text{total } I_{B_{dc}} = 1372 - 18 = 1354 \text{ A}$$

$$\text{total ground current} = 1877 + 1354 = 3231 \text{ A}_{\text{peak}}$$

For comparison, at 84° travel, the current is 3230 A, and at 86° travel, the current is 3229 A.

5.4.7 Calculating the area [see item e) of 5.4.2]

To find the area under the total current wave between zero crossings, find the time of the second crossing. This can be done through trial and error. In this example, t_2 equals 0.0270139 s after the start of the phase C fault current, or t_2 equals 0.0341419 s from the start of phase B. As before, the area can be broken down into parts.

Area No. 1, under the dc offset for the initial phase B current, is shown in Figure 17.

$$\text{Area No. 1} = 1677(-0.01039) \left[e^{\left(\frac{-0.007128}{0.01039} \right)} - 1 \right] = 8.649 \text{ A}\cdot\text{s}$$

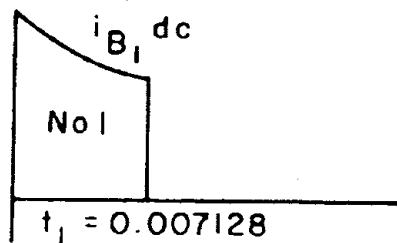

Figure 17—DC offset and determination of Area No. 1 and for the initial phase B current

Area No. 2, under the dc offset for the second phase B current, is shown in Figure 18.

$$\text{Area No. 2} = -39(-0.00525) \left[e^{\left(\frac{-0.0270139}{0.00525} \right)} - 1 \right] = 0.20 \text{ A}\cdot\text{s}$$

Area No. 3, under ac below axis for the initial phase B current, is shown in Figure 19.



Figure 18—DC offset and determination of Area No. 2 and for the second phase B current

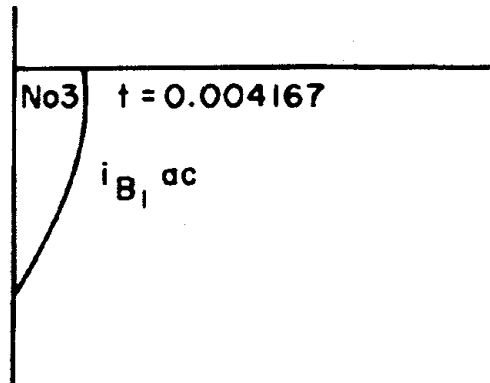

Figure 19—Determination of Area No. 3 for the initial phase B current

$$\text{Area No. 3} = \frac{1677}{377}(-1) = -4.448 \text{ A}\cdot\text{s} \text{ for } 1/4 \text{ of a sine wave}$$

Area No. 4, under ac above axis for the initial phase B current, is shown in Figure 20.

$$\begin{aligned} \text{Area No. 4} &= I_{B_1} \int_{(0.004167 - 0.004167)}^{(0.007128 - 0.004167)} \sin 377t \, dt = \frac{-1677}{377} [\cos 377(0.00296) - \cos 377(0)] \\ &= 4.448 (\cos 1.1163 - 1) = -4.448 (\cos 63.96 - 1) = 2.496 \text{ A}\cdot\text{s} \end{aligned}$$

Areas No. 5 and No. 6, under ac of second phase B current, are shown in Figure 21.

NOTE—In this figure, areas A + C = B + D and, therefore, they cancel each other.

$$\begin{aligned} \text{Area No. 5} &= I_{B_2} = \int_{(t_1 - 0.004167)}^{(0.00833 - 0.004167)} \sin 377t \, dt = \frac{-2662}{377} [\cos 337(0.004167) - \cos 377(0.002961)] \\ &= -7.061 (\cos 1.5708 - \cos 1.1163) = -7.061 (\cos 90^\circ - \cos 63.96^\circ) = -7.061 - (0.43899) = 3.100 \text{ A}\cdot\text{s} \end{aligned}$$

$$\text{Area No. 6} = I_{B_2} \int_{(0.03333 - 0.020833)}^{(t_2 - 0.020833)} \sin 377t \, dt$$

where

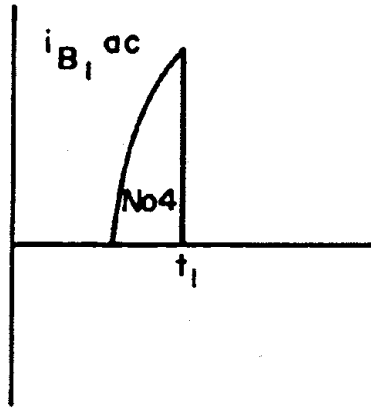

Figure 20—Determination of Area No. 4 for the initial phase B current

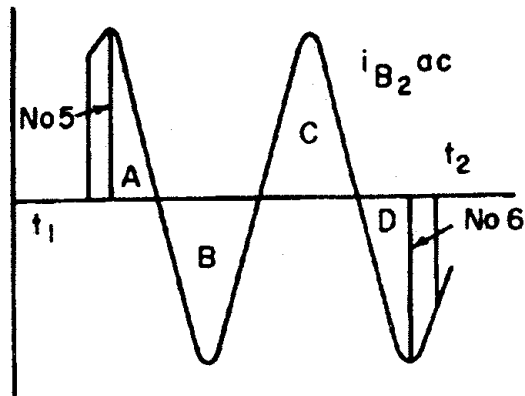

Figure 21—Determination of Areas No. 5 and No. 6 for the second phase B current

$$t_2 = 0.0341419 = \frac{-2662}{377} [\cos 377(0.0133086) - \cos 377(0.0125)]$$

$$= -7.061(\cos 5.01734 - \cos 4.7125) = -7.061(\cos 287.47^\circ - \cos 270^\circ) = -7.061(0.30015 - 0) = 2.119 \text{ A}\cdot\text{s}$$

Area No. 7, under the dc offset for phase C current, is shown in Figure 22.

$$\text{Area No. 7} = 2526(-0.02113) \left[e^{\left(\frac{-0.0270139}{0.02113}\right)} - 1 \right]$$

$$= 2526(-0.02113)(e^{-1.27846} - 1) = 53.374(-0.72153) = 38.511 \text{ A}\cdot\text{s}$$

Area No. 8, under the ac of phase C current, is shown in Figure 23.

NOTE—Areas A + C = B + D and, therefore, they cancel each other.

$$\text{Area No. 8} = I_{C_{ac}} = \int_{0.024999}^{t_2} (\cos 377t \, dt)$$

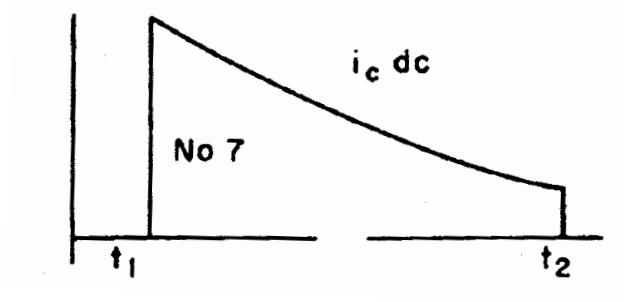

Figure 22—Determination of Area No. 7 under the dc offset for phase C current

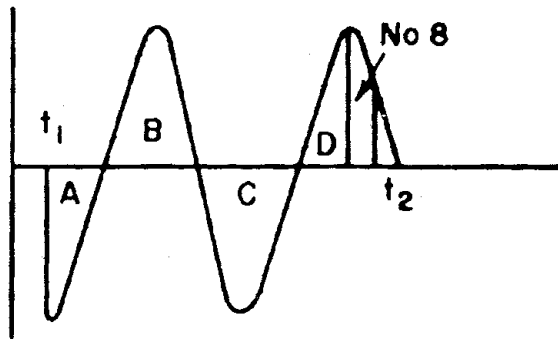

Figure 23—Area No. 8

where

$$\begin{aligned}
 t_2 &= 0.0270139 = \frac{-2526}{377} [\sin 377(0.0270139) - \sin 377(0.024999)] \\
 &= -6.700 [\sin (10.18424) - \sin (9.4249)] = -6.700 [\sin 583.5^\circ - \sin 540^\circ] = -6.700 [\sin 223.5^\circ - 0] \\
 &= -6.700 [-0.6885] = +4.613 \text{ A}\cdot\text{s}
 \end{aligned}$$

| | |
|----------------------------------|--------------|
| Total area under current curve = | 8.649 |
| | -0.20 |
| | -4.448 |
| | 2.496 |
| | 3.100 |
| | -2.119 |
| | 38.511 |
| | <u>4.613</u> |
| | 50.602 A·s |

A 60 Hz wave with the same area for one-half cycle would have

$$I = 0.5 (377) 50.602 = 9538 \text{ A}_{\text{peak}}, \text{ or } 6745 \text{ A}_{\text{rms}} \text{ (see Figure 24)}$$

A lower frequency wave with same peak and half cycle area would be

$$f = \frac{3231(2)}{2\pi(50.602)} = \frac{3231}{158.96} = 20.32 \text{ Hz}$$

The area is equal to $1.5 (50.602) = 75.90 \text{ V}\cdot\text{s}$.

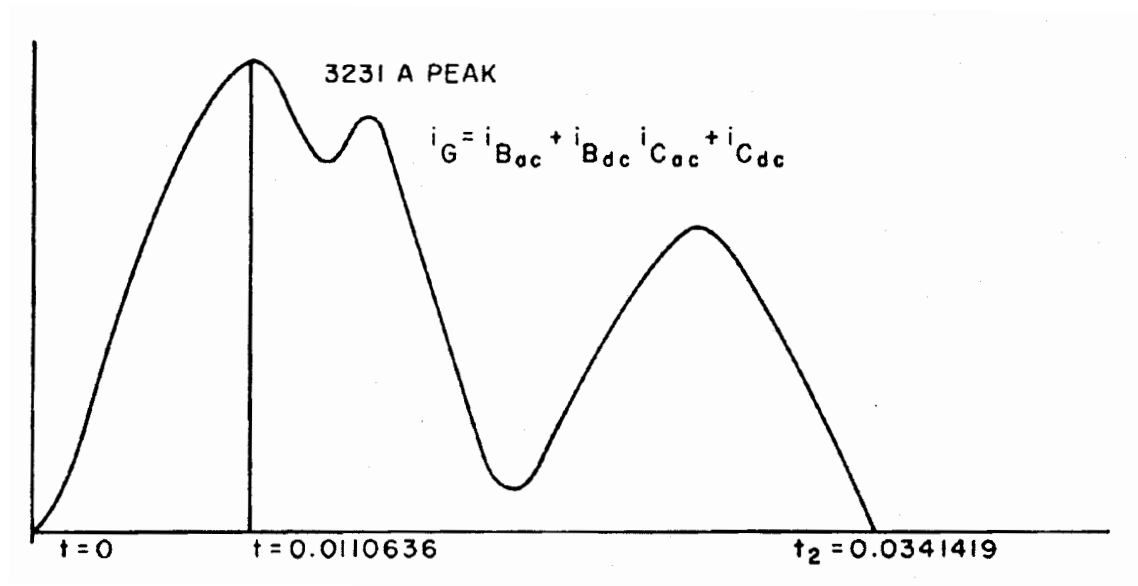

Figure 24—Total current for an evolving fault

5.4.8 Calculating the GPR and voltage curve area [see item f) of 5.4.2]

The resultant GPR for the evolving fault case is $3231 \text{ A}_{\text{peak}} (1.5 \Omega) = 4847 \text{ V}_{\text{peak}}$.

5.4.9 Overhead ground wires

As indicated in 5.5.1, it is important to note that the example assumes there are no overhead ground wires or other alternate fault current return paths. Should there be overhead ground wires that carry shielding current during a fault or other return paths, such as water pipes, rails, etc., a prior calculation would be necessary to determine the split of the return paths for the fault current. Then one should use only that portion of total fault current actually returning via the earth path for the GPR calculation.

5.5 Summary

5.5.1 Reduction factors

While the objective of this clause is to provide examples of the calculation for worst-case or maximum GPR voltages under single-phase and double phase-to-ground fault conditions, the likelihood of an evolving double-phase fault occurring with the critical time intervals required to produce worst-case conditions is remote. Even a single phase-to-ground fault occurring under ordinary operating conditions and initiated at the worst possible time is remote. Therefore, by individual judgment, reduction factors may be applied to worst-case GPR values, as shown in Clause 10.

5.5.2 Station ground reactive component

Although the common practice is to ignore the reactive component of the station ground in the impedance values used for GPR calculations, caution should be exercised since it is known that the reactive component may have an appreciable value, particularly in large ground grid situations. The reactive component can be significant when the ground grid impedance is estimated to be less than 1Ω .

Figure 25 shows the relative wave forms applicable to the previous calculations.

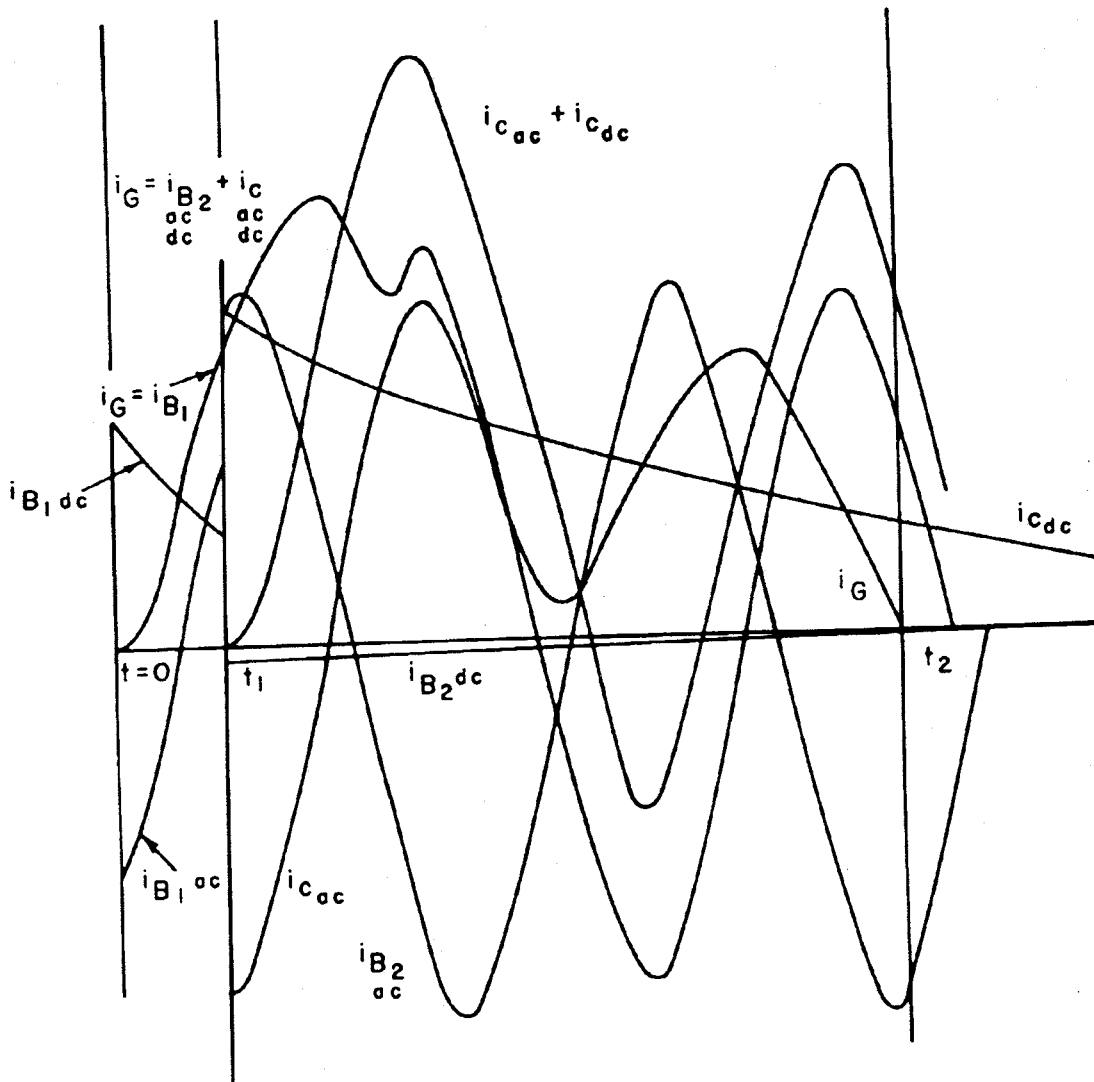

Figure 25—Combined relative waveforms

6. Calculation of electromagnetic induction under power fault conditions

This clause presents a simple method of calculating electromagnetic 60 Hz longitudinal induction in a telecommunication line when exposed to an overhead electric supply line under fault conditions. Induction from

lightning surges is not included. This part considers only grounded power systems and uses values of inducing currents or L-G fault currents as supplied by the power company concerned. While the emphasis is on transmission lines, it is applicable to all grounded power systems. However, care should be exercised when telecommunication cable shields are bonded to power system multigrounded neutrals associated with lower voltage supply lines because of the additional factors introduced by the changes in return current distribution.

When an electric supply line that parallels an overhead or underground telecommunication line experiences a ground fault during which fault current returns through ground, a potentially dangerous longitudinal voltage is electromagnetically induced in the telecommunication line. Almost without exception, the magnitude of this induced voltage far exceeds the electromagnetically induced voltage encountered under normal operation of the supply line.

The magnitude of such induction depends chiefly on separation and length of inductive exposure between the supply and telecommunication lines, the magnitude of the fault current in the earth return path, and the earth resistivity. The values of earth resistivity to be used in the calculation and the distribution of the return fault current are difficult factors to ascertain with accuracy.

While there are more rigorous methods of calculation, the one presented here will give a good approximation of induced voltages to be expected. A higher degree of precision would demand greater accuracy in the parameters, including the value of earth resistivity. Metallic sheathed electric supply cables (overhead and underground) are not considered in this clause.

6.1 Inducing current

The value of inducing current given by the power utility depends upon many parameters, including the effects of other supply lines, overhead ground wires, or conductors that play a part in the fault calculations. Where the effects of other supply lines or conductors can be neglected, the inducing current can be taken either as the ground return current or the fault current modified by return through lightning protection wires (overhead ground wires), rails, pipes, etc.

This gives a fairly rigorous solution, and the inducing current can be either in terms of absolute magnitude or complex values. Note that an inducing current is calculated for each supply source acting in the exposure.

6.2 Mutual impedance

In the calculations that follow, the major emphasis is on the determination of the mutual impedance between the disturbing and the disturbed circuits. If the lines involved are not reasonably parallel, the total exposure is sectionalized and then the mutual impedance determined for each section. The sum of these values is then taken as the total mutual impedance. A more rigorous treatment would consider phase changes in induction as separation is changed, particularly for large changes, for example, 50–1000 ft (15–300 m). The method used here ignores such phase changes and could therefore produce higher values than actually present. Figures 28 through 33 assume average earth resistivity throughout the inductive exposure.

The following examples consider symmetrical fault current. The mutual impedance values using Figures 31 through 33 (SI units) are based on conversion of the separation and length in feet or kilofeet rounded off to suitable significant figures in meters or kilometers, respectively.

Formulation for calculating the external mutual impedance of parallel supply and telecommunication circuits was developed by J. R. Carson [B9].

The general configuration for mutual impedance is shown in Figure 26. The solution of Carson's mutual impedance integral in SI units is

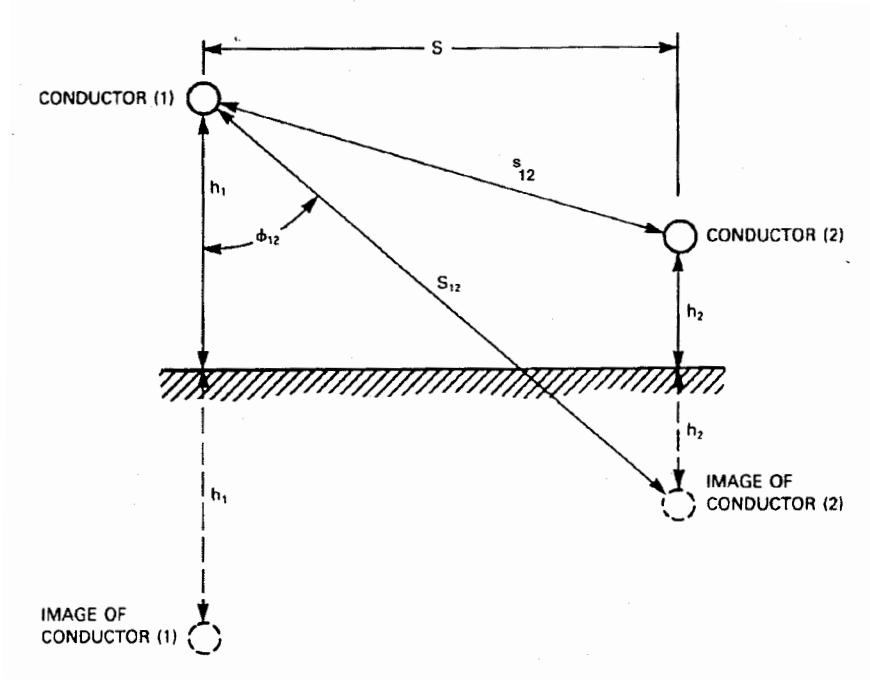

Figure 26—General configuration for mutual impedance

$$Z_m = \Delta R'_{12} + j[2\omega 10^{-4} \ln \frac{S_{12}}{s_{12}} + \Delta X'_{12}] (\Omega/\text{km})$$

where

Z_m is the mutual impedance per unit length;

$\Delta R'_{12}$ are corrections that account for the earth return effect (functions of ϕ_{12});

$\Delta X'_{12}$

ϕ_{12} is the angle defined in Figure 26;

ω is $2\pi f$, which is equal to the angular frequency of the inducing current;

S is the horizontal separation between supply and telecommunication lines;

S_{12} is the distance between conductor (1) and image of conductor (2) (m);

s_{12} is the distance between conductors (1) and (2) (m).

Defining parameter a :

$$a = 0.851 S_{12} \sqrt{\frac{f}{\rho}}$$

where

ρ is the earth resistivity ($\Omega \cdot \text{m}$) $\left[\frac{1}{\sigma} \right]$.

When a is less than or equal to 5:

$$\Delta R'_{12} = 4\omega 10^{-4} \left\{ \frac{\pi}{8} - b_1 a \cos\phi_{12} + b_2 [(c_2 - \ln a)a^2 \cos 2\phi_{12} + \phi_{12} a^2 \sin 2\phi_{12}] + \dots \right\}$$

$$\Delta X'_{12} = 4\omega 10^{-4} \left\{ \frac{1}{2} (0.6159315 - \ln a) + b_1 a \cos\phi_{12} - d_2 a^2 \cos 2\phi_{12} + \dots \right\}$$

where

$$\cos\phi_{12} \text{ is equal to } \frac{(h_1 + h_2)}{S_{12}};$$

$$\sin\phi_{12} \text{ is equal to } \frac{S}{S_{12}};$$

h_1 is the height of conductor (1) (m);

h_2 is the height of conductor (2) (m);

S is the horizontal separation between conductors (1) and (2) (m).

$$b_i = b_{i-2} \frac{1}{i(i+2)}$$

where

i is an integer;

and with starting values of

b_1 is 0.23570 for odd subscripts;

b_2 is 0.0625 for even subscripts.

$$c_i = c_{i-2} + \frac{1}{i} + \frac{1}{i+2} \text{ with a starting value of } c_2 = 1.3659315$$

$$d_i = \frac{\pi}{4} b_i$$

When a is greater than 5:

$$\Delta R'_{12} = \left(\frac{\cos\phi_{12}}{a} - \frac{\sqrt{2}\cos 2\phi_{12}}{a^2} + \frac{\cos 3\phi_{12}}{a^3} + \frac{3\cos 5\phi_{12}}{a^5} - \frac{45\cos 7\phi_{12}}{a^7} \right) \frac{4\omega 10^{-4}}{\sqrt{2}}$$

$$\Delta X'_{12} = \left(\frac{\cos\phi_{12}}{a} - \frac{\cos 3\phi_{12}}{a^3} + \frac{3\cos 5\phi_{12}}{a^5} - \frac{45\cos 7\phi_{12}}{a^7} \right) \frac{4\omega 10^{-4}}{\sqrt{2}}$$

where

$$\cos\phi_{12} = \frac{h_1 + h_2}{S_{12}};$$

$$\sin\phi_{12} = \frac{S}{S_{12}}.$$

References [B54] and [B54] describe the conditions under which Carson's formula is sufficiently accurate for determining mutual impedance. The formula is valid for the power frequency and all its harmonics below 5 kHz. Carson's formula can also be used for buried telecommunication lines if the log term is eliminated and h_2 is replaced by a negative number with magnitude equal to the burial depth. The only restriction on this use is that the burial depth be a small fraction of the skin depth in the earth. A simpler procedure that is more valid in most practical cases is to simply evaluate Carson's formula at the earth surface directly above the buried telecommunication cable, which is accurate to within 5%, as long as the burial depth in homogeneous soil does not exceed 2 m and the distance to the supply line is much greater than the burial depth.

Figures 28 through 33 are derived from Carson's formula in [B9]. These figures are for 60 Hz and assume average earth resistivity throughout the inductive exposure. Earth resistivity may vary widely, both geographically and seasonally. Where a higher accuracy is required in the calculation of mutual impedance, measuring the earth resistivity profile along the exposure under extreme seasonal conditions (that is, dry soil, frozen soil, etc.) is usually necessary. A simplified approximation of Carson's formula, known as the "extended complex image" formula (see [B56]), is as follows:

$$Z_m = R_m + jX_m = j\omega \frac{\mu_0}{2\pi} \left[\ln\left(\frac{D_1}{D_0}\right) - \frac{1}{12} \left(\frac{2}{\gamma D_1}\right)^4 \right] (\Omega/\text{km}) \quad (25)$$

where

- Z_m is the mutual impedance per unit length;
- R_m is the mutual resistance per unit length;
- jX_m is the mutual reactance per unit length;
- ω is the angular frequency of the inducing current ($2\pi f$);
- f is the frequency of the inducing current (Hz);
- μ_0 is the rationalized permeability of free space ($4\pi 10^{-7}$ H/m).

$$D_0 = [(S)^2 + (h_1 - h_2)^2]^{1/2} (\text{m})$$

$$D_1 = \left[(S)^2 + \left(h_1 + h_2 + \frac{2}{\gamma} \right)^2 \right]^{1/2} (\text{m})$$

$$\gamma = \sqrt{j\omega\mu_0\sigma}$$

where

- h_1 is the height of conductor (1) (m);
- h_2 is the height of conductor (2) (m);
- σ is the earth conductivity ($1/\rho$).

NOTE— Z_m is a complex quantity with resistive (R_m) and reactive (X_m) parts. The quantities D_1 and γ are also complex.

The extended complex image formula provides results that are valid to within 5% of Carson's formula for the following values of D_0 :

$$D_0 < \frac{0.5}{|\gamma|} \text{ m and } D_0 > \frac{5}{|\gamma|} \text{ m}$$

For other values of D_0 , variations of up to 20% may occur. Buried telecommunication lines are handled with the same accuracy as in Carson's formula, providing burial depth is less than 2 m.

6.3 General formula

For an inductive exposure with uniform separation between a supply and a telecommunication line, the LI voltage in an unshielded telecommunication conductor can be calculated using the following formula:

$$V = Z_m I \text{ (V)}$$

where

- Z_m is the product of the mutual impedance z_m , expressed in $R+jX \text{ } \Omega/\text{kft}$ or $\text{ } \Omega/\text{km}$ and L ;
- L is the length of the exposure (kft or km);
- I is the inducing current supplied by the power utility (A).

6.4 Examples of calculations

The following subclauses will provide examples of how to evaluate the general formula under different conditions.

6.4.1 Example 1: Uniform exposure

An example involving an inductive exposure with uniform separation between a supply line and a telecommunication line will demonstrate the general formula. Figure 27 is an illustration of this example. Figures 28 and 31 give the mutual resistance (per kilofoot and per kilometer, respectively), and Figures 29 and 32 give the mutual reactance (per kilofoot and per kilometer, respectively). These figures are based on a power system frequency of 60 Hz; horizontal separation between the disturbing and disturbed lines; earth resistivity; and, for supply and telecommunication line height, differences of 25 ft (7.5 m). Figures 30 and 33 give the absolute value of mutual impedance (per kilofoot and per kilometer, respectively) for the same line height differences. Absolute values are used to simplify calculations.

Given a parallel inductive exposure between a supply and a telecommunication line, as shown in Figure 27, where

- S is the horizontal separation between supply and telecommunication lines [100 ft (30 m)];
- D is the difference in line heights [25 ft (7.5 m)];
- ρ is the earth resistivity (1000 $\Omega\cdot\text{m}$);
- L is the length of exposure [10.25 kft (3.1 km)];
- I is the inducing current (absolute value) (3000 A);
- z_m is the mutual impedance (complex) (Ω/kft or Ω/km);
- $|z_m|$ is the mutual impedance (absolute) (Ω/kft or Ω/km);
- Z_m is the mutual impedance (total) (Ω);
- V is the LI voltage.

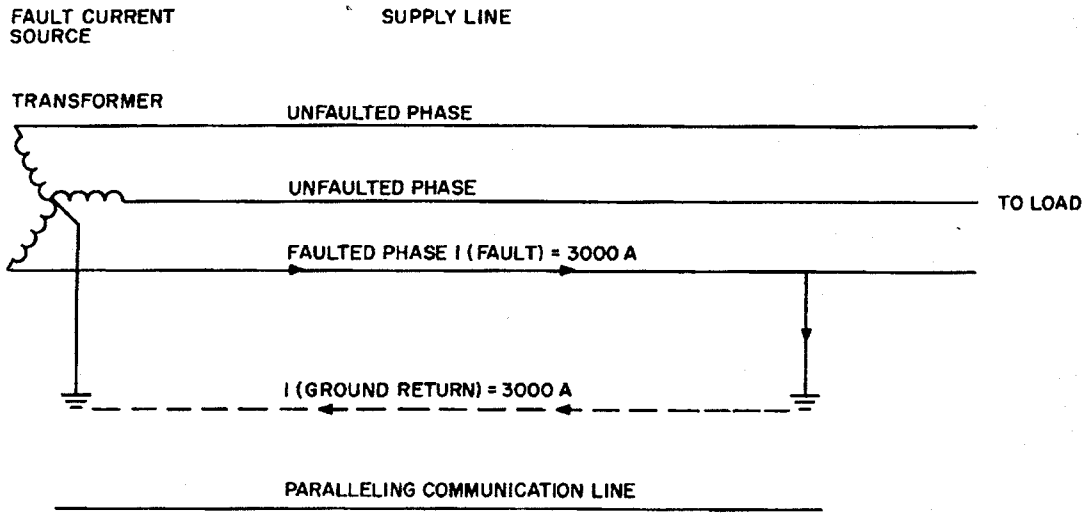

NOTE—In this case, the total fault current returns through the ground and, therefore, the fault current is also the inducing current.

Figure 27—Illustration for Example 1

6.4.1.1 Determination of LI voltage using complex values of mutual impedance

$$S = 100 \text{ ft}$$

$$R = 0.018 \text{ } \Omega/\text{kft (from Figure 28)}$$

$$X = 0.103 \text{ } \Omega/\text{kft (from Figure 29)}$$

$$z_m = 0.018 + j0.103 \text{ } \Omega/\text{kft}$$

$$Z_m = z_m L = (0.018 + j0.103)10.25 = 0.185 + j1.056 \text{ } \Omega$$

$$V = Z_m I = (0.185 + j1.056)3000$$

$$|V| = 3216 \text{ V}$$

$$S = 30 \text{ m}$$

$$R = 0.059 \text{ } \Omega/\text{km (from Figure 31)}$$

$$X = 0.34 \text{ } \Omega/\text{km (from Figure 32)}$$

$$z_m = 0.059 + j0.34 \text{ } \Omega/\text{km}$$

$$Z_m = z_m L = (0.059 + j0.34)3.1 = 0.184 + j1.054 \text{ } \Omega$$

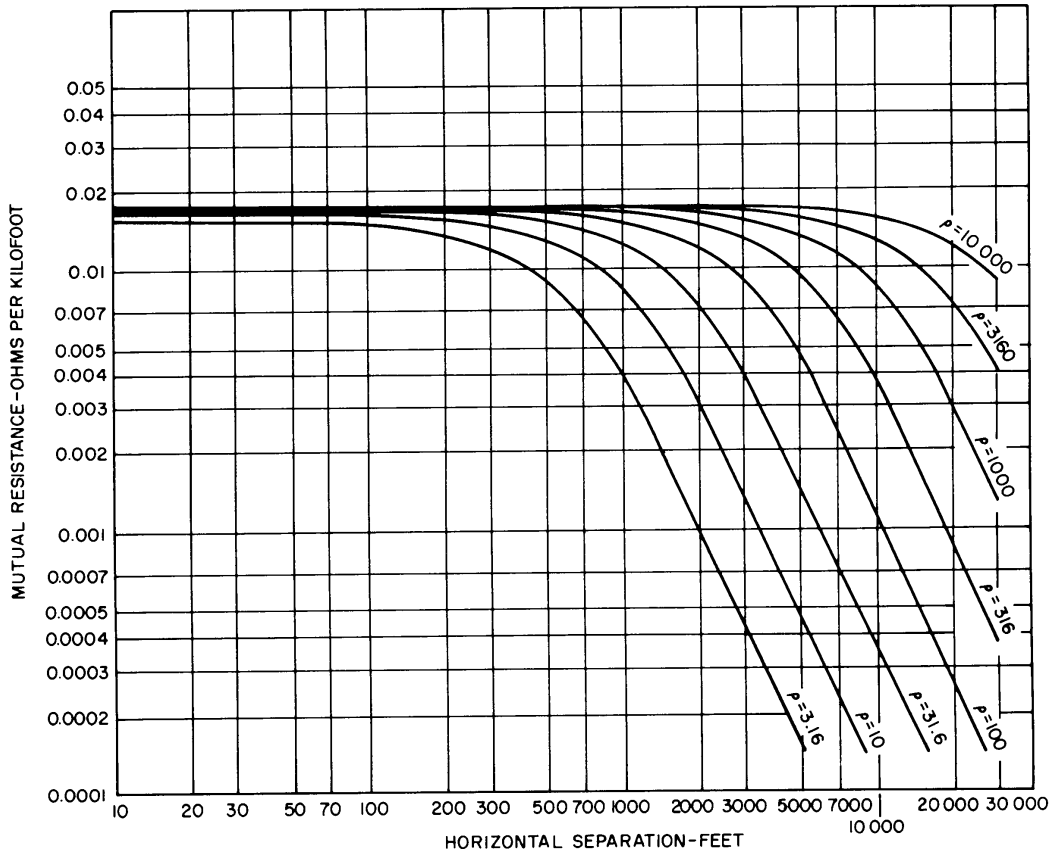

NOTE—Earth resistivity, ρ , as shown on curves, is in $\Omega\cdot\text{m}$.

Figure 28—Mutual resistance of ground-return circuits

$$V = Z_m I = (0.184 + j1.054)3000$$

$$|V| = 3210 \text{ V}$$

NOTE—In each case, V is the LI voltage in an unshielded telecommunication conductor.

6.4.1.2 Determination of LI voltage using absolute values of mutual impedance

$$S = 100 \text{ ft}$$

$$|z_m| = 0.104 \text{ } \Omega/\text{kft} \text{ (from Figure 30)}$$

$$|Z_m| = |z_m|L = 0.104 \times 10.25 = 1.066 \text{ } \Omega$$

$$V = |Z_m|I = 1.066 \times 3000 = 3198 \text{ V}$$

$$S = 30 \text{ m}$$

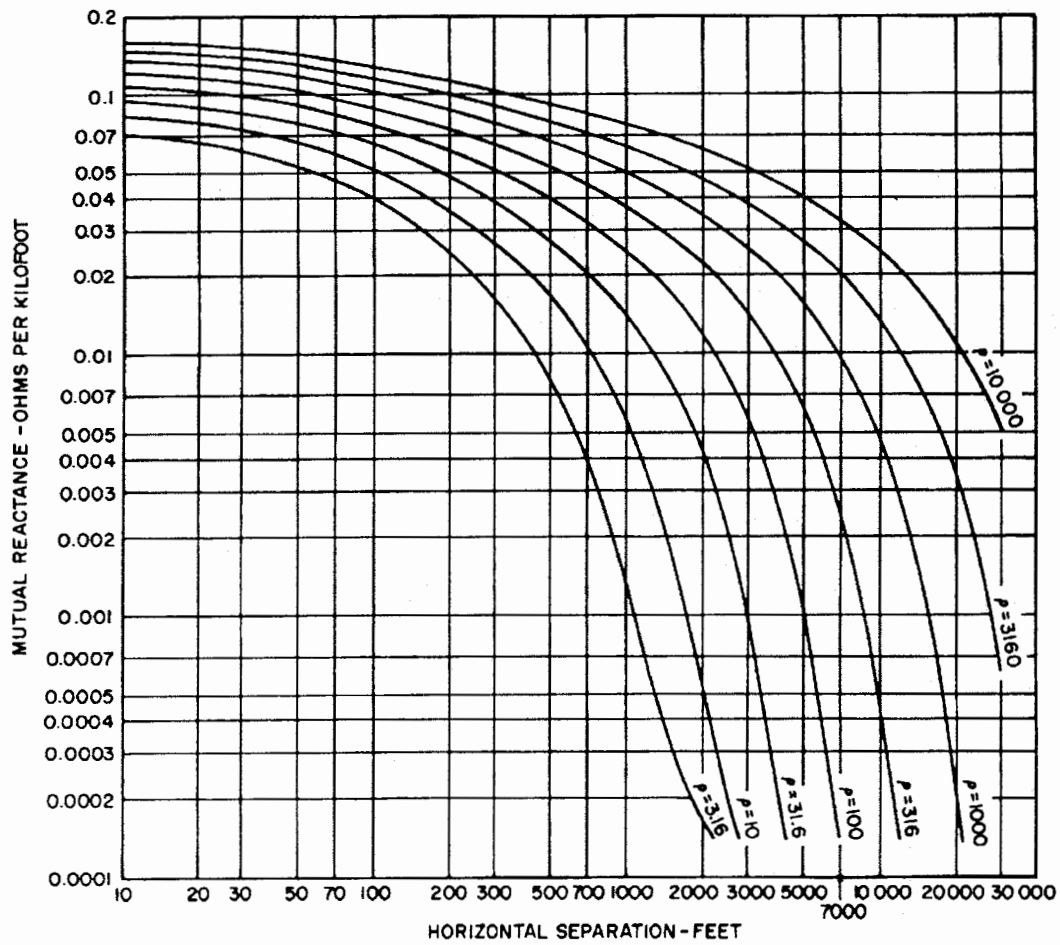

NOTE 1—Difference in average line heights, D , equals 25 ft.
 NOTE 2—Earth resistivity, ρ , as shown on curves, is in $\Omega\cdot\text{m}$.
 NOTE 3—For other values of D , refer to Figure 38.

Figure 29—Mutual reactance of ground-return circuits

$$|z_m| = 0.34 \text{ } \Omega/\text{km (from Figure 33)}$$

$$|Z_m| = |z_m|L = 0.34 \times 3.1 = 1.054 \text{ } \Omega$$

$$V = |Z_m|I = 1.054 \times 3000 = 3162 \text{ V}$$

For relatively close uniform separations, as shown previously, there is little error in using the absolute values of mutual impedance.

6.4.1.3 Evaluation of mutual impedance

Mutual impedance is a function of separation between disturbing and disturbed lines and earth resistivity. This recommended practice uses average values of earth resistivity.

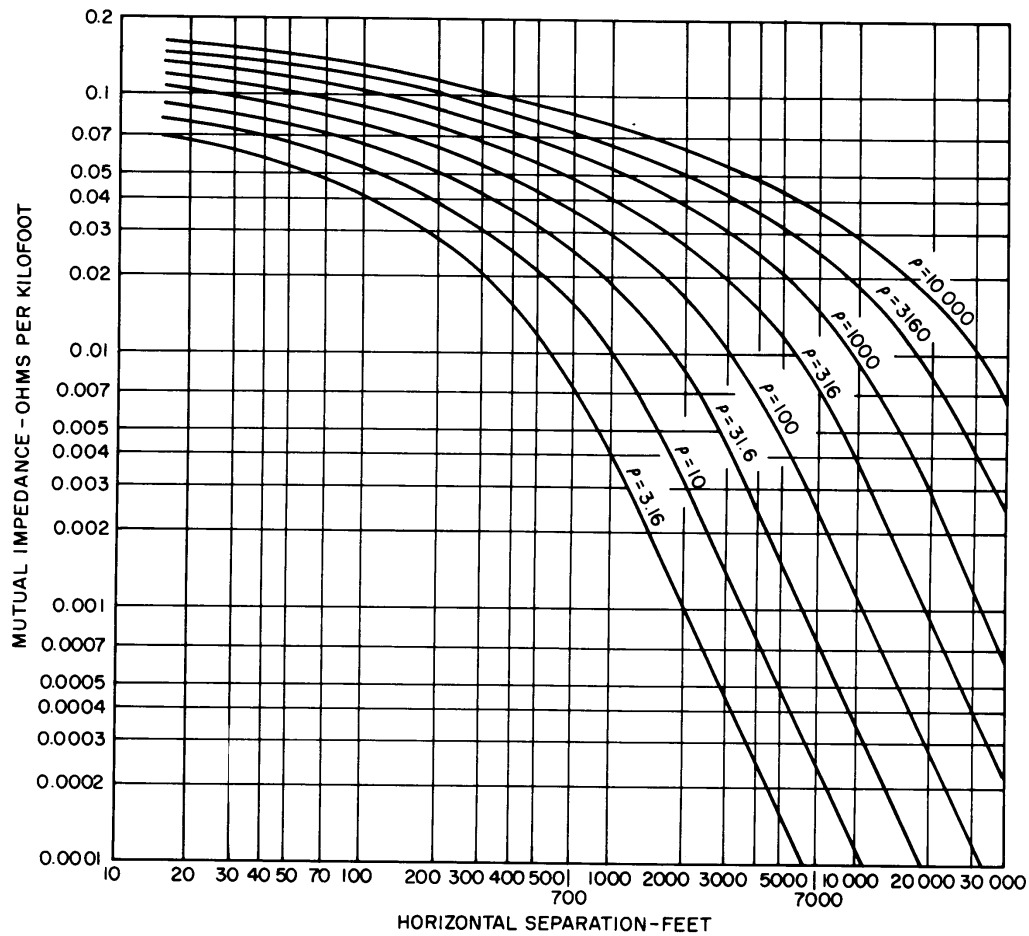

NOTE 1—Difference in average line heights, D , equals 25 ft.

NOTE 2—Earth resistivity, ρ , as shown on curves, is in $\Omega\cdot\text{m}$.

NOTE 3—For other values of D , refer to Figure 38.

Figure 30—Mutual impedance of ground-return circuits

The earth is a complex mass. Inductive coupling tests between lines in the vicinity of the one being considered can aid in its determination. This type of test circulates a known current in the line-to-ground mode of the supply line and measures the LI voltage in the paralleling telecommunication line. With this method, the volts per ampere (ohms) or the absolute value of mutual impedance modified by other return paths can be determined. Where the current is confined to the phase conductor-earth return path, the average value of earth resistivity can be deduced from the absolute value of mutual impedance obtained and by use of Figures 30 or 33. This technique is most suitable where uniform exposures are involved or where they can be sectionalized. Other sampling techniques of measuring earth resistivity can also be used. These measurements are fairly difficult to make and do not always give very accurate information on the resistivity of the deep strata, which is important in the determination of inductive coupling between the lines. Table 3 gives values of earth resistivity to be expected based on the nature of the ground.

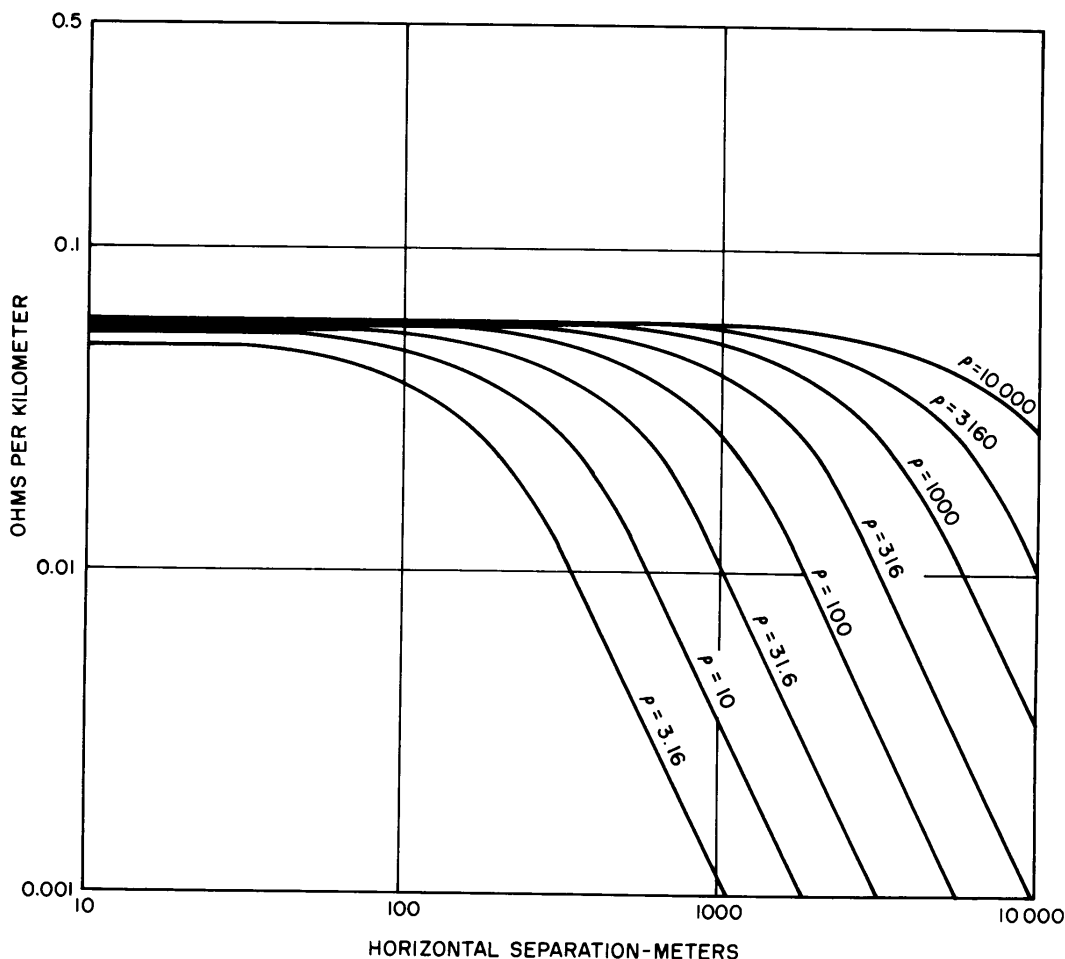

NOTE—Earth resistivity, ρ , as shown on curves, is in $\Omega \cdot m$.

Figure 31—Mutual resistance of ground-return circuits in SI units

6.4.1.4 Nonuniform or slanting inductive exposures

Example 1 in 6.4.1 is based on a uniform “parallel” exposure, and the curves in Figures 28 through 33 give values of mutual resistance, reactance, or impedance, directly. In most exposures, the supply line is not wholly parallel to the telecommunication line, and separation varies throughout the exposure. In such cases, it is convenient to project reasonably straight, paralleling or slanting, sections of the telecommunication line onto the supply line on a suitable map. Figure 34 shows a typical exposure and the method of projection of the telecommunication line $AB \dots MN$ on to the supply line XY with projected lengths $ab \dots mn$. The LI voltage for each of the sections $AB \dots MN$ projected on XY becomes $V_{ab} \dots V_{mn}$. These are calculated, and the total LI voltage V is the phasor sum of the induced voltages V_{ab} to V_{mn} . Therefore, where the telecommunication line reverses direction with respect to the supply line, the fault current acts in an opposite direction, and the resultant induced voltage for such a section is subtractive. Figures 34 and 35 show special angularities of lines. When the power and the telecommunication lines diverge as shown in Figure 36, the projection should be made as shown in this figure. The length $P'Q'$ is not subjected to any induction, and it is merely necessary to add the induced voltage in PP' by (pz) and in $Q'Q'$ by (zq) .

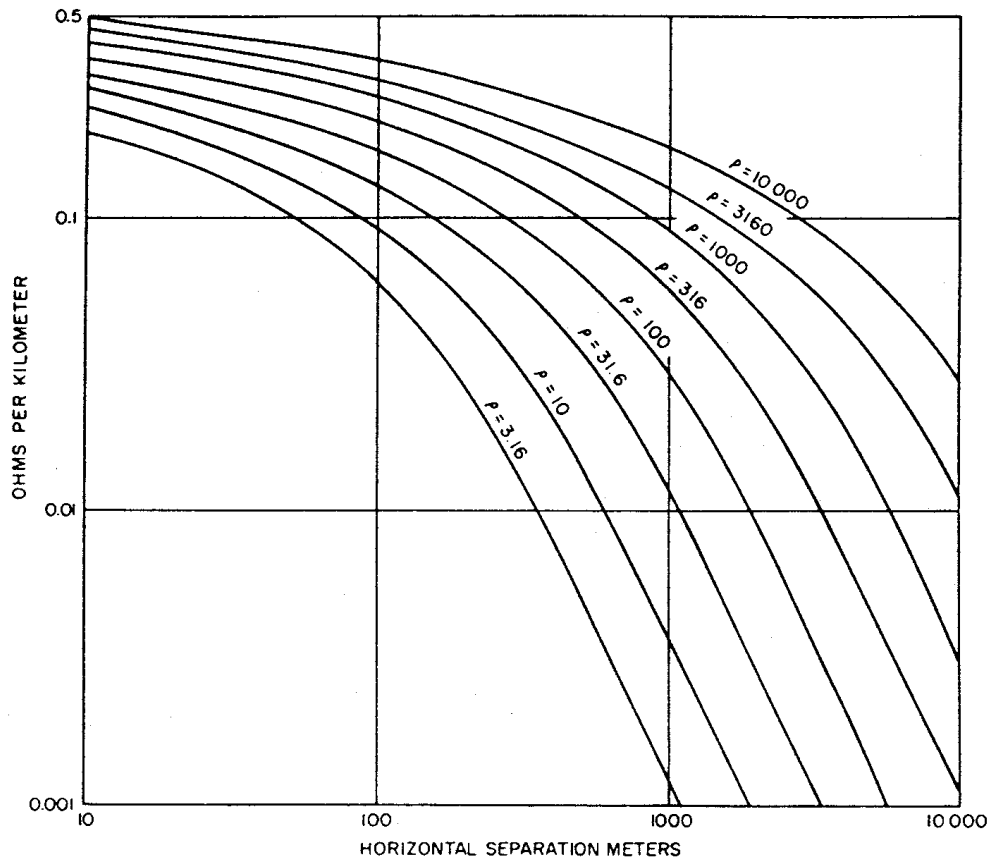

- NOTE 1—Difference in average line heights, D , equals 7.5 m.
 NOTE 2—Earth resistivity, ρ , as shown on curves, is in $\Omega\cdot\text{m}$.
 NOTE 3—For other values of D , refer to Figure 38.

Figure 32—Mutual reactance of ground-return circuits in SI units

6.4.1.5 Calculation of mutual impedance (per unit length)

The complex or absolute value of mutual impedance (per unit length) is obtained directly from Figures 28 through 33 (see 6.4.1, Example 1).

Subdivide the slanting sections, if necessary, so that the ratio of the maximum separation to minimum separation does not exceed 2. At a crossing, the minimum separation is to be taken as 15 ft (5 m).

The complex or absolute value of mutual impedance (per unit length) is first determined for the separations at the end of each section using Figures 28 through 33. The mutual impedance for the section is obtained by taking the average of the values determined for the ends of the section.

There usually will be no appreciable error in avoiding further subdivision of slanting sections where the telecommunication line is within 15 ft (5 m) from the supply line conductor on each side of the crossing. A fixed separation of 15 ft (5 m) can be used in these cases.

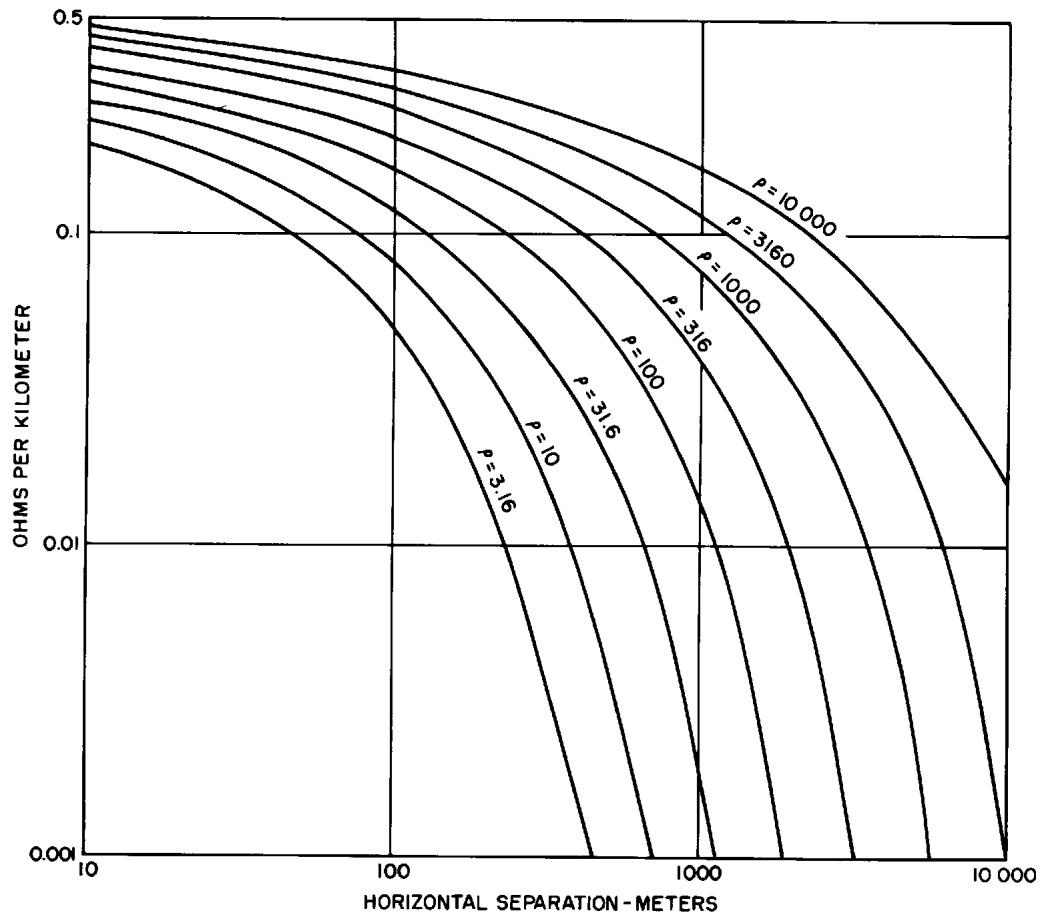

NOTE 1—Difference in average line heights, D , equals 7.5 m.
 NOTE 2—Earth resistivity, ρ , as shown on curves, is in $\Omega \cdot \text{m}$.
 NOTE 3—For other values of D , refer to Figure 38.

Figure 33—Mutual impedance of ground-return circuits in SI units

6.4.2 Example 2: Nonuniform exposure

Given a nonuniform inductive exposure between a supply and telecommunication line, as shown in Figure 34, where

- S is the horizontal separation between supply and telecommunication lines (see Figure 34);
- ρ is the earth resistivity ($1000 \Omega \cdot \text{m}$);
- I is the inducing current (absolute value) (2000 A);
- D is the difference in line heights [25 ft (7.5 m)];
- L is the length of exposure (see Figure 34);
- z_m is the mutual impedance (complex) (Ω/kft or Ω/km);
- $|z_m|$ is the mutual impedance (absolute) (Ω/kft or Ω/km);
- Z_m is the mutual impedance (total) (Ω);
- V is the LI voltage [total (see 6.4.1.4)].

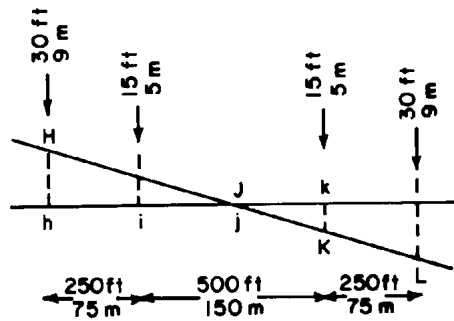
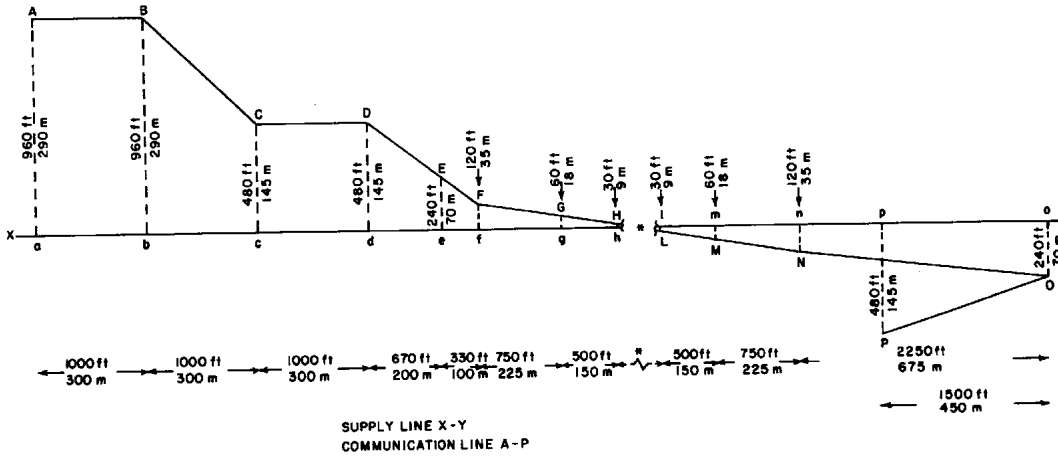
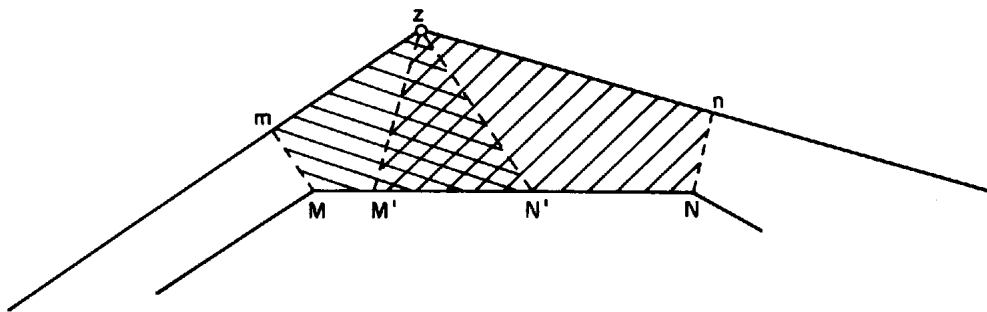
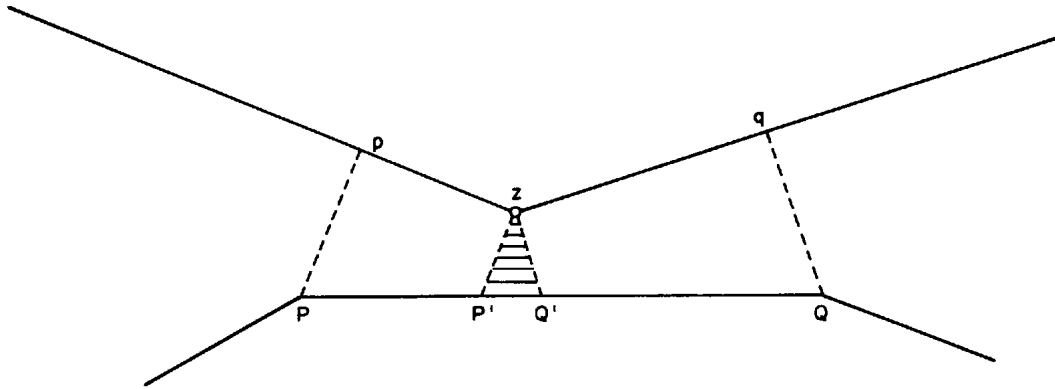

Figure 34—Inductive exposure for Example 2



NOTE—The M'N' is induced twice (by mz and zn). Therefore, the induced voltage in Mn' and M'N is added.

Figure 35—Converging inductive exposure



NOTE— The section P'Q' is not counted.

Figure 36—Diverging inductive exposure

The exposure is divided into sections showing separations and lengths of projections as demonstrated in Figure 34. The section within 15 ft (5 m) of each side of the crossing has been neglected. The slanting sections, shown as *DF*, *FH*, and *LN*, have been subdivided in order to keep the ratio of maximum separation to minimum separation to 2 or below.

Table 4 shows the values of separation, the length (*L*) of each section, values of z_m (*R* and *X* per kilofoot), and corresponding values of *R* and *X* for each section using both complex and absolute values. The induced voltage per section (*V*) is shown and is computed using these values and the inducing current of 2000 A. Table 5 gives the same data in SI units.

From Table 4, the sum of the complex values of induced voltage in an unshielded telecommunication conductor is

$$V = 284 + j1387$$

$$|V| = 1416 \text{ V}$$

Also, the sum of the absolute values of induced voltage is

$$|V| = 1408 \text{ V}$$

From Table 5, the corresponding values of induced voltage using SI units are in complex values.

$$V = 284 + j1368$$

$$|V| = 1397 \text{ V}$$

And in absolute values:

$$|V| = 1391 \text{ V}$$

In most cases, where only absolute values of induction are required, the use of absolute values of mutual impedance (from Figures 30 and 33) will give sufficient accuracy.

Table 3—Earth resistivity

| Earth resistivity (Ω·m) | Quarternary | Cretaceous Tertiary Quarternary | Carboniferous Triassic | Cambrian Ordovician Devonian | Precambrian and combination with Cambrian | |
|-------------------------|---|---------------------------------|------------------------|------------------------------|--|--|
| 1 Sea water | | | | | | |
| 10 Unusually low | | Loam | | | | |
| | | Clay | | | | |
| | | Chalk | | | | |
| 30 (dry rock) | | | | Chalk | | |
| 100 Low | | | | Trap | | |
| | | | | Diabase | | |
| | | | | Shale | | |
| | | | | Limestone | | |
| 300 Medium | | | | Sandstone | Shale | |
| | | | | Limestone | | |
| 1 000 High | | | | Sandstone | | |
| 3 000 Very high | Coarse sand and gravel in surface areas | | | Dolomite | Sandstone Quartzite Slate Granite | |
| 10 000 Unusually high | | | | | Gneisses | |

6.5 Cumulative mutual impedance and electromagnetic induction curves

For electromagnetic induction calculations, a graphical picture of cumulative mutual impedance can be prepared as shown in Figure 37. Mutual impedance (Z_m) for each section of the inductive exposure for Example 2 is plotted against exposure length. The straight line for Example 1 (uniform exposure and resistivity) is also shown for comparison. In a similar manner, a cumulative induction curve can be prepared using the absolute values of v in Example 2. This is particularly useful for finding the induced voltage in a specific section of the exposure. For Example 2, its shape would be essentially the same as the cumulative mutual impedance curve.

Table 4—Example 2 calculations

| Section (from Figure 34) | L (kft) | Complex values | | | Absolute values | | |
|--|------------|--|---|--------------------------------|--|----------------------------------|-----------------------|
| | | z_m from Figures 28 and 29 ($R + jX$) (Ω/kft) | $Z_m = z_m L$ ($R + jX$) L (Ω) | $V = Z_m I$ (V) | $ z_m $ from Figure 30 (Ω/kft) | $ Z_m = z_m L$ (Ω) | $ V = Z_m I$ (V) |
| Section <i>AB</i> (<i>ab</i>)—Parallel S_A and $S_B = 960$ ft | 1 | 0.018 + j 0.050 | 0.018 + j 0.050 | 36 + j 100 | 0.054 | 0.054 | 108 |
| Section <i>BC</i> (<i>bc</i>) $S_B = 960$ ft $S_C = 480$ ft | 1 | av $\frac{0.018 + j0.050}{0.018 + j0.068}$ 0.018 + j 0.059 | 0.018 + j 0.059 | 36 + j 118 | av $\frac{0.054}{0.068}$ 0.061 | 0.061 | 122 |
| Section <i>CD</i> (<i>cd</i>)—Parallel S_C and $S_D = 480$ ft | 1 | 0.018 + j 0.068 | 0.018 + j 0.068 | 36 + j 136 | 0.068 | 0.068 | 136 |
| Section <i>DE</i> (<i>de</i>) $S_D = 480$ ft $S_E = 240$ ft | 0.67 | av $\frac{0.018 + j0.068}{0.018 + j0.084}$ 0.018 + j 0.076 | 0.012 + j 0.051 | 24 + j 102 | av $\frac{0.068}{0.085}$ 0.077 | 0.052 | 103 |
| Section <i>EF</i> (<i>ef</i>) $S_E = 240$ ft $S_F = 120$ ft | 0.33 | av $\frac{0.018 + j0.084}{0.018 + j0.100}$ 0.018 + j 0.092 | 0.006 + j 0.030 | 12 + j 61 | av $\frac{0.085}{0.100}$ 0.093 | 0.031 | 61 |
| Section <i>FG</i> (<i>fg</i>) $S_F = 120$ ft $S_G = 60$ ft | 0.75 | av $\frac{0.018 + j0.100}{0.018 + j0.112}$ 0.018 + j 0.106 | 0.014 + j 0.080 | 28 + j 160 | av $\frac{0.100}{0.115}$ 0.108 | 0.081 | 162 |
| Section <i>GH</i> (<i>gh</i>) $S_G = 60$ ft $S_H = 30$ ft | 0.5 | av $\frac{0.018 + j0.112}{0.018 + j0.124}$ 0.018 + j 0.118 | 0.009 + j 0.059 | 18 + j 118 | av $\frac{0.115}{0.125}$ 0.120 | 0.060 | 120 |
| Section <i>HI</i> (<i>hi</i>) $S_H = 30$ ft $S_I = 15$ ft | 0.25 | av $\frac{0.018 + j0.124}{0.018 + j0.131}$ 0.018 + j 0.128 | 0.005 + j 0.032 | 10 + j 64 | av $\frac{0.125}{0.133}$ 0.129 | 0.032 | 64 |
| Section <i>KL</i> (<i>kl</i>) Same as <i>HI</i> | 0.25 | 0.018 + j 0.128 | 0.005 + j 0.032 | 10 + j 64 | 0.129 | 0.032 | 64 |
| Section <i>LM</i> (<i>lm</i>) Same as <i>GH</i> | 0.5 | 0.018 + j 0.118 | 0.009 + j 0.059 | 18 + j 118 | 0.120 | 0.060 | 120 |
| Section <i>MN</i> (<i>mn</i>) Same as <i>FG</i> | 0.75 | 0.018 + j 0.106 | 0.014 + j 0.080 | 28 + j 160 | 0.108 | 0.081 | 162 |
| Section <i>NO</i> (<i>no</i>) $S_N = 120$ ft $S_O = 240$ ft | 2.25 | av $\frac{0.018 + j0.100}{0.018 + j0.084}$ 0.018 + j 0.092 | 0.041 + j 0.207 | 82 + j 414 | av $\frac{0.100}{0.085}$ 0.093 | 0.209 | 418 |
| Section <i>OP</i> (<i>op</i>)* $S_O = 240$ ft $S_P = 480$ ft | 1.5 | av $\frac{0.018 + j0.084}{0.018 + j0.068}$ 0.018 + j 0.076 | 0.027 + j 0.114 | -54 - j 228 | av $\frac{0.085}{0.068}$ 0.077 | 0.116 | -232 |
| Total induced voltage | | | | 284 + j 1387 $ V = 1416$ | | | 1408 |

* I acts in opposite direction for this section.

Table 5—Example 2 calculations—SI units

| Section (from Figure 34) | L (km) | Complex values | | | Absolute values | | |
|---|-----------|--|---|--------------------|---|----------------------------------|-----------------------|
| | | z_m from Figures 31 and 32 ($R + jX$) (Ω/kft) | $Z_m = z_m L$ ($R + jX$) L (Ω) | $V = Z_m I$ (V) | $ z_m $ from Figure 33 (Ω/km) | $ Z_m = z_m L$ (Ω) | $ V = Z_m I$ (V) |
| Section <i>AB</i> (<i>ab</i>)—Parallel S_A and $S_B = 290$ m | 0.3 | 0.06 + j 0.17 | 0.018 + j 0.051 | 36 + j 102 | 0.180 | 0.054 | 108 |
| Section <i>BC</i> (<i>bc</i>) $S_B = 290$ m $S_C = 145$ m | 0.3 | av $\frac{0.06 + j0.17}{0.06 + j0.22}$ 0.06 + j 0.195 | 0.018 + j 0.059 | 36 + j 118 | av $\frac{0.18}{0.22}$ 0.20 | 0.060 | 120 |
| Section <i>CD</i> (<i>cd</i>)—Parallel S_C and $S_D = 145$ m | 0.3 | 0.06 + j 0.22 | 0.018 + j 0.066 | 36 + j 132 | 0.22 | 0.066 | 132 |
| Section <i>DE</i> (<i>de</i>) $S_D = 145$ m $S_E = 70$ m | 0.2 | av $\frac{0.06 + j0.22}{0.06 + j0.38}$ 0.06 + j 0.25 | 0.012 + j 0.050 | 24 + j 100 | av $\frac{0.22}{0.28}$ 0.25 | 0.050 | 100 |
| Section <i>EF</i> (<i>ef</i>) $S_E = 70$ m $S_F = 35$ m | 0.1 | av $\frac{0.06 + j0.28}{0.06 + j0.32}$ 0.06 + j 0.30 | 0.006 + j 0.030 | 12 + j 60 | av $\frac{0.280}{0.330}$ 0.305 | 0.031 | 61 |
| Section <i>FG</i> (<i>fg</i>) $S_F = 35$ m $S_G = 18$ m | 0.225 | av $\frac{0.06 + j0.32}{0.06 + j0.37}$ 0.06 + j 0.345 | 0.014 + j 0.078 | 28 + j 156 | av $\frac{0.330}{0.380}$ 0.355 | 0.080 | 160 |
| Section <i>GH</i> (<i>gh</i>) $S_G = 18$ m $S_H = 9$ m | 0.15 | av $\frac{0.06 + j0.37}{0.06 + j0.41}$ 0.06 + j 0.39 | 0.009 + j 0.059 | 18 + j 118 | av $\frac{0.380}{0.410}$ 0.395 | 0.059 | 118 |
| Section <i>HI</i> (<i>hi</i>) $S_H = 9$ m $S_I = 5$ m | 0.075 | av $\frac{0.06 + j0.41}{0.06 + j0.43}$ 0.06 + j 0.42 | 0.005 + j 0.032 | 10 + j 64 | av $\frac{0.41}{0.43}$ 0.42 | 0.032 | 64 |
| Section <i>KL</i> (<i>kl</i>) Same as <i>HI</i> | 0.075 | 0.06 + j 0.42 | 0.005 + j 0.032 | 10 + j 64 | 0.42 | 0.032 | 64 |
| Section <i>LM</i> (<i>lm</i>) Same as <i>GH</i> | 0.15 | 0.06 + j 0.39 | 0.009 + j 0.059 | 18 + j 118 | 0.395 | 0.059 | 118 |
| Section <i>MN</i> (<i>mn</i>) Same as <i>FG</i> | 0.225 | 0.06 + j 0.345 | 0.014 + j 0.078 | 28 + j 156 | 0.355 | 0.080 | 160 |
| Section <i>NO</i> (<i>no</i>) $S_N = 35$ m $S_O = 70$ m | 0.675 | av $\frac{0.06 + j0.32}{0.06 + j0.28}$ 0.06 + j 0.30 | 0.041 + j 0.203 | 82 + j 406 | av $\frac{0.330}{0.280}$ 0.305 | 0.206 | 412 |
| Section <i>OP</i> (<i>op</i>)* $S_O = 70$ m $S_P = 145$ m | 0.45 | av $\frac{0.06 + j0.28}{0.06 + j0.22}$ 0.06 + j 0.25 | 0.027 + j 0.113 | -54 - j 226 | av $\frac{0.28}{0.22}$ 0.25 | 0.113 | -226 |
| Total induced voltage | | | 284 + j 1368 $ V = 1397$ | | | 1391 | |

* I acts in opposite direction for this section.

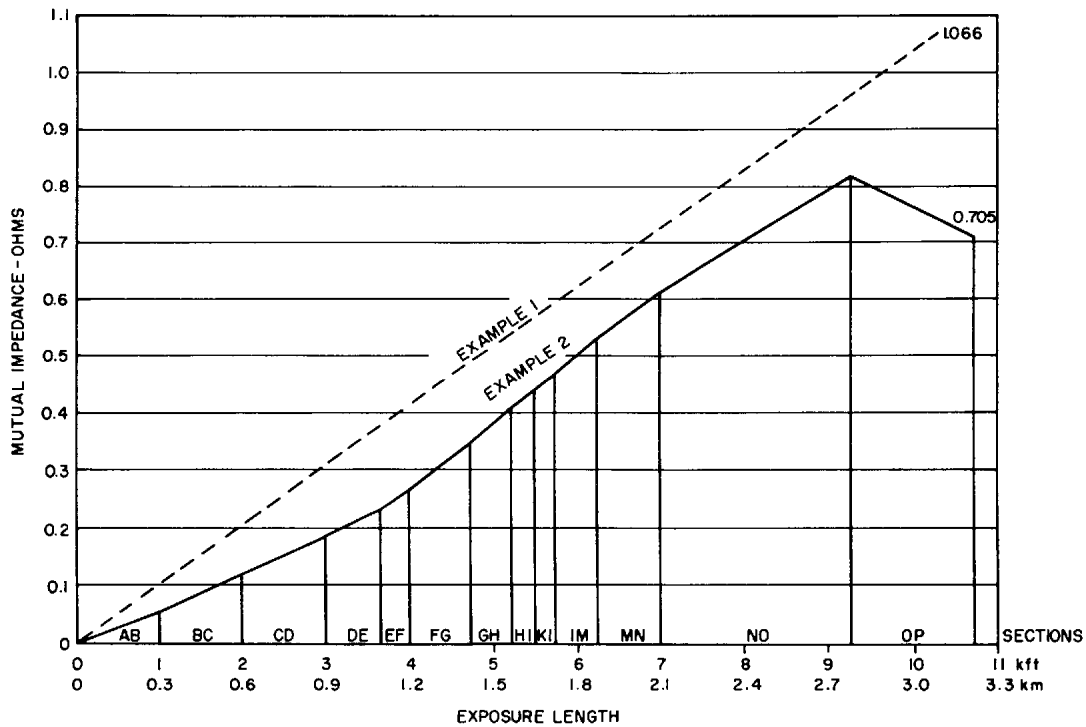

Figure 37—Cumulative mutual impedance curves for Examples 1 and 2

6.6 Correction for difference in line heights

Examples 1 and 2 have been calculated using Figures 29, 30, 32, and 33 directly because the difference in supply and communication line heights was taken as 25 ft (7.5 m). For horizontal separations less than 100 ft (30 m), Figure 38 gives the correction factor for other differences in average line heights (see Figure 38 and Example 3 for sample calculations). In most cases the corrections are relatively small.

6.7 Electric supply line with double-end feed

Where the supply line has a double-end feed (from *X* and *Y* directions in Figure 39), the inducing currents act in opposite directions. Therefore, when evaluating the resultant induced voltage for a specific portion of the exposure, care should be taken to ensure that opposite signs are used when adding up the contributions from each power source.

6.8 Fault location for maximum induced voltage

For a single-ended supply feed and a reasonable uniform separation, the fault location giving maximum induced voltage is usually at the end of the exposure remote from the supply feed. For irregular separations, this is not necessarily true.

In the case of a double-ended supply feed and uniform separation, the location giving maximum induced voltage is usually at that end of the exposure where the value of fault current from the furthest supply source is the highest. Figure 39 shows the locations of supply line faults leading to the maximum values of induced voltages for *AB* and *BC* as separate exposures and also when connected together as exposure *AC*.

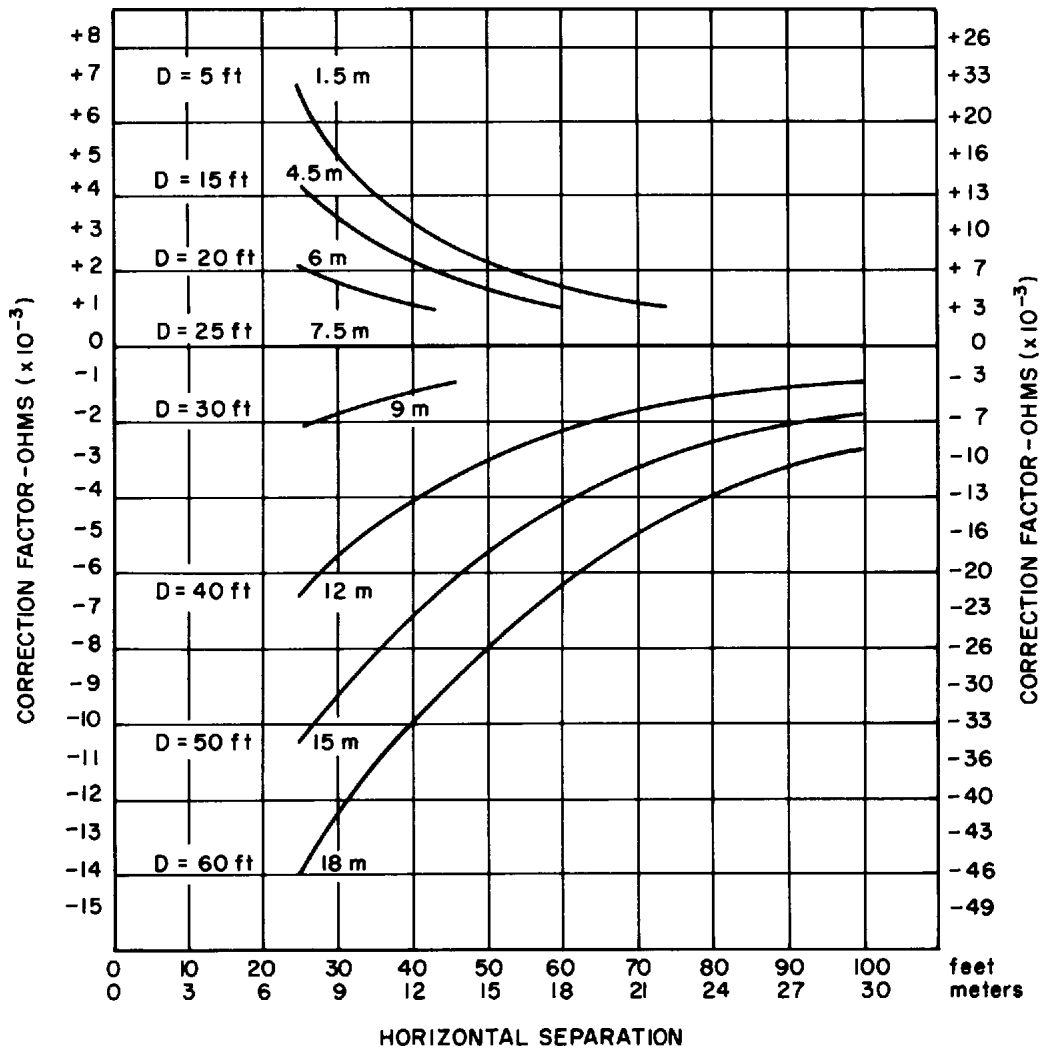

NOTE 1—The above chart gives the correction factors to be added to the values obtained from Figures 29, 30, 32, and 33 to allow for the differences in heights of supply and telecommunication lines. Note that the values directly from Figures 29 and 30 and Figures 32 and 33, are based on height differences of 25 ft and 7.5 m, respectively.

NOTE 2—Example: The value from Figure 29 for a horizontal separation of 40 ft and earth resistivity, ρ , of 31.6 Ω -m, is 0.082 Ω /kft. This is for a height difference of 25 ft. If the height difference was actually 60 ft, the correction factor would be -10×10^{-3} , or -0.01, Ω /kft. The corrected value would then be 0.082 - 0.01 or 0.072 Ω /kft.

NOTE 3—For Figures 29 and 30, separations are given in feet, whereas in Figures 32 and 33, separations are given in meters.

Figure 38—Correction factors for differences in line heights

6.9 Shield factor

The electromagnetically induced voltage V , as discussed previously, is the voltage induced in an unshielded telecommunication line. A shield factor is used to take into account the shielding action of all grounded conductors (overhead ground wires, rails, metallic pipes), including metallic sheaths of telecommunication cables, etc., in an inductive exposure.

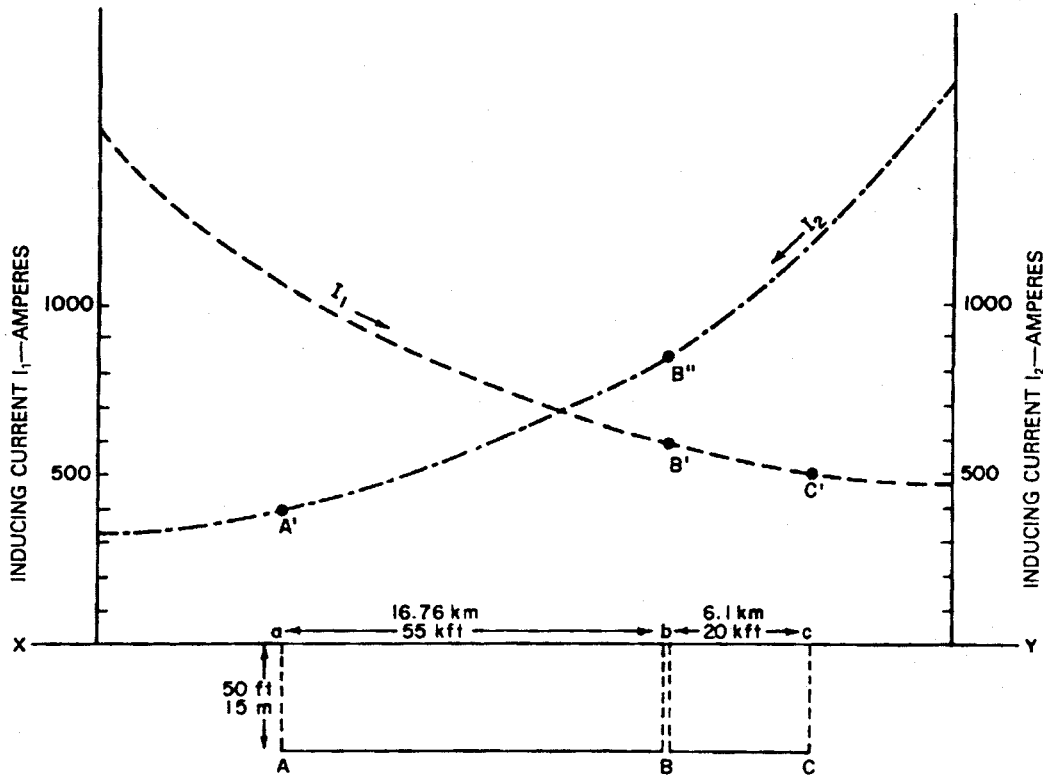

XY is the supply line
 AB, BC are communication lines (not interconnected at point B)
 I_1 is the inducing current coming from the X-end
 I_2 is the inducing current coming from the Y-end

Fault locations for maximum induced voltage:

Exposure AB : Inducing current I_1 (value at B) from X-end
 Exposure BC : Inducing current I_2 (value at B) from Y-end
 Exposure AC : Inducing current I_1 (value at C) from X-end

Figure 39—Double-ended supply system feed and inductive exposures for Example 3

As on each section there can be several shielding conductors, the overall shield factor for each section can be H , which is approximately the product of all shield factors for that section:

$$H = \eta_1 \times \eta_2 \dots \eta_m$$

This is true only if the individual shielding conductors act independently of each other. Where the shielding conductors are close enough that one has an effect on another, the resultant shield factor may be greater than the product.

The induced voltage for a section (v^s), considering the overall shield factor H for sections, is

$$v^s = V \times H$$

and for all sections combined (V^s):

$$V^s = \sum_{i=1}^{\eta} v^s$$

where

i is the total number of sections.

6.9.1 Evaluation of shield factor

The shielding action of nearby conductors is effective if their impedances are low, if they have low impedance grounds (particularly at their ends), and if they are close to the disturbing (inducing) line or the disturbed line (in general less than 30 ft or 9 m).

In practice, the shield factor should be considered in two stages:

- a) The shield factor associated with the disturbing line (that is, the supply line)

NOTE—The value of inducing current I given by the power utility takes into account the return current distribution.

- b) The shield factor associated with the disturbed line (that is, the telecommunication wire line)

Since each shield factor depends on a number of parameters as already indicated, the exact value should be established by calculation or by tests for both a given design of overhead supply line and also for the telecommunication line.

For telecommunication cables with aluminum or copper shield only, the shield factor does not vary much over a wide range of inducing currents. When magnetic armoring is applied over the metallic shield, the shield factor will depend on the flux density in the armoring; that is, on the magnitude of the induced current in the conducting shield. Due to the shape of the magnetizing curve, the effectiveness of such armoring is reduced both at low- and also at high-flux densities. Certain steel-tape armored telecommunication cables show a minimum value for the shield factor for conditions when the induced voltage is 150–300 V/kft (500–1000 V/km).

In the case of asymmetrical fault currents, the di/dt associated with the dc offset, while not contributing significantly to the magnitude of induction, may increase the flux requirements of cable shields.

6.9.2 Shield factor for electric supply lines with overhead ground wires

Many steel tower and wood pole supply lines have one or more (up to four) overhead ground wires (lightning protection wires or skywires) that are usually bonded to each tower or pole ground. There can be a number of such paralleling lines on an ROW, and these tower lines can be either bussed together at both terminating stations or they can terminate in more than two stations. This means that a fault on a particular phase of one of these circuits will produce a heavy zero-sequence fault current in the faulted phase flowing towards the fault from one or both directions. The currents in the two unfaulted phases of the faulted circuit will, depending on the relative size and distribution of positive-sequence fault currents, be smaller and flow in the direction opposite to that of the faulted phase. In addition, the remaining circuits on the faulted tower line and circuits on the unfaulted paralleling tower lines on the faulted ROW will produce zero-sequence fault currents flowing in the directions dictated by their terminal connections. Currents in their respective phases will, generally, be unequal and will not necessarily flow in the same direction.

These facts should be included in the determination of the net inducing current, taking into account the relative separations of each phase on the ROW and the telecommunication line. The vector sum of currents induced in the overhead ground wire of the faulted tower line from all of these conductors can be deducted from the fault current entering the fault. This current does not enter the earth but stays in the overhead ground wire and flows in the direction opposite to the fault current. This current will induce in the telecommunication line a voltage that counteracts the induced voltage into the same line from the currents in the phase conductors, thereby producing shielding action.

In addition to reduction of the fault current for the purpose of determining the “net” inducing current by subtracting the induced overhead ground wire current, further reduction takes place through the effect of the current dissipation into the earth conductively through the tower- or pole-footing ground impedances. Near the fault, overhead ground wire may carry up to 80% of the fault current, which is then gradually dissipated into the earth at each successive tower or pole. For long lines, the ratio of ground wire current to ground current becomes relatively constant between the supply source and the faulted tower or pole. In order to determine properly the amount of current conducted into the earth, one needs to model the impedance of the overhead ground wire-tower ladder networks. Techniques employing both distributed and lumped parameter methods are now available. Their extension also allows for including the inductive shielding effects of counterpoises and other buried ground conductors.

If the previously mentioned reductions are not included in the information provided by the power utility, additional shield factors should be considered to take care of these conditions.

The shield factor range may be estimated according to Table 6, where the inductive exposure is relatively remote from the source and from the fault location.

For inductive exposure locations close to the supply source, or to the fault location, the value of fault-current split should be computed.

Table 6—Shield factors for supply line with overhead ground wires

| Overhead ground wire type* | 60 Hz shield factor | |
|--|---------------------|-------------|
| | Single wire | Double wire |
| DC resistance of wires less than 0.2 Ω/mi (0.1 Ω/km) | 0.55–0.7 | 0.4–0.5 |
| DC resistance of wires less than 0.8 Ω/ml (0.5 Ω/km) | 0.65–0.75 | 0.65–0.75 |
| DC resistance of wires less than 1.6 Ω/ml (1.0 Ω/km) | 0.8–0.9 | 0.8–0.9 |

* In the case of double overhead ground wires, the resistance shown relates to the resulting value of the two wires in parallel.

6.9.3 Shield factor for continuously grounded telecommunication cables with metallic shields

Shield factors for telecommunication cables depend upon many factors, such as

- a) *Location of the shield*—most effective if located in proximity to either the disturbed or disturbing conductor
- b) *Earth resistivity*—the ratio of mutual and self-impedances determine the shielding current in the shield conductor. Both the numerator and the denominator of the ratio are influenced by the earth resistivity in the same direction; hence, variation in earth resistivity causes relatively small changes in the shielding factor.

Typical 60 Hz shield factors for aluminum-shielded cables are given in Table 7. Shield factors for a compound steel-aluminum shielded cable are given in Table 8. Shield factors for double steel-tape armored cable are given in Table 9. In the tables, Z_T is the total shield terminating ground resistance and L is the length of cable.

Table 7—Shield factors for Alpth communication cable*

| Cable size | DC shield resistance | | 60 Hz shield factor for given Z_T/L | | | |
|-------------------|-------------------------|------------------------|---------------------------------------|-------|------|---------------------|
| | (Ω/kft) | (Ω/km) | | | | |
| | | | 1.0 | 0.2 | 0 | Ω/kft |
| | | | 3.28 | 0.656 | 0 | Ω/km |
| 11 pair 26 gauge | 1.34 | 4.40 | 0.99 | 0.98 | 0.97 | |
| 300 pair 19 gauge | 0.28 | 0.92 | 0.97 | 0.90 | 0.80 | |

*Alpth cable with 0.008 in (0.02 cm) aluminum shield.

Table 8—Shield factors for Stalpeth communication cable*

| Primary field | | 60 Hz shield factor for given Z_T/L | | | |
|---------------------------|--------------------------|---------------------------------------|------|------|---------------------|
| (V/kft) | (V/km) | | | | |
| | | 1.0 | 0.3 | 0 | Ω/kft |
| | | 3.28 | 0.98 | 0 | Ω/km |
| 22.9 | 75 | 0.95 | 0.81 | 0.53 | |
| 45.7 | 150 | 0.93 | 0.74 | 0.47 | |
| 68.6 | 225 | 0.91 | 0.72 | 0.52 | |

* Stalpeth cable, 1.94 in (4.93 cm) core diameter, with 0.008 in (0.02 cm) aluminum shield and 0.006 in (0.015 cm) steel shield. DC shield resistance is equal to 0.37 Ω/kft (1.21 Ω/km).

- c) *Impedance of shielding circuit, including the shield conductor grounds*—should be the lowest achievable. For the cables with thin nonferromagnetic shields, the inductive shielding mechanism is relatively ineffective as a mitigation technique for 60 Hz induction. Ferromagnetic-shielded cables usually have much better 60 Hz shield factors due to their enhanced permeability. Their shield factors will vary with the shield current, and their optimum values will depend upon the induced volt-

age per unit length and the impedance of the shield grounds. Improved shielding can be obtained for nonferrous polyethylene-jacketed telecommunication cables by paralleling the cable with a grounded high-conductivity shield or messenger wire. The shielding improves as additional grounds are attached. This is especially effective for buried cable where the bare shield wire is in continuous contact with the earth (see Figure 40). If the bare shield wire is bonded periodically to the cable shield, the combination now approaches the lower shield factors of buried unjacketed lead cables and assists in shielding the cable from lightning.

Table 9—Shield factors for tape-armored communication cable *

| Primary field | | 60 Hz shield factor for given Z_T/L | | | |
|---------------|--------|---------------------------------------|------|------|---------------------|
| (V/kft) | (V/km) | | | | |
| | | 1.0 | 0.3 | 0 | Ω/kft |
| | | 3.28 | 0.98 | 0 | Ω/km |
| 22.9 | 75 | 0.84 | 0.54 | 0.16 | |
| 45.7 | 150 | 0.80 | 0.47 | 0.13 | |
| 68.6 | 225 | 0.77 | 0.44 | 0.11 | |
| 100.6 | 330 | 0.74 | 0.41 | 0.09 | |
| 300.2 | 985 | 0.67 | 0.40 | 0.11 | |

*Tape-armored cable, 200 pair, with 0.008 in (0.02 cm) aluminum shield and two 0.041 in (0.104 cm) steel tapes. DC resistance (shield and tapes) is equal to 0.14 Ω/kft (0.46 Ω/km).

- d) *Shielding circuit reactance*—leading to maximum shielding action is determined by the other constants in the system. For instance, if the shielding circuit has a low impedance, an insertion of a low negative reactance will improve shielding. If, on the other hand, the impedance is high, an addition of a small positive reactance will be helpful.
- e) *Mutual impedance*—can be changed by special means without changing separations, and involves adjusting mutual impedance and reactance to equal self-impedance and reactance.
- f) *Frequency*—both the resistive and reactive components of mutual impedance increase with increased frequency.

An illustration of 60 Hz shield factors for a buried nonferromagnetic shield telecommunication cable with continuous leakage to ground provided by a supplementary bare shield wire is shown in Figure 40. The length of inductive exposure is varied to demonstrate its effect on shield factors.

6.10 Typical supply line fault current distribution

Figure 41 shows typical fault current distributions for faults occurring at different locations. As with the shielding effects of overhead ground wires, the location of the fault, its position relative to the inductive exposure, and the length of the exposure will determine whether averaging values of inducing currents are satisfactory in the induction calculations. For example, a short exposure near an assumed tower fault location could involve great differences in inducing currents at each end of the exposure; that is, a large overhead

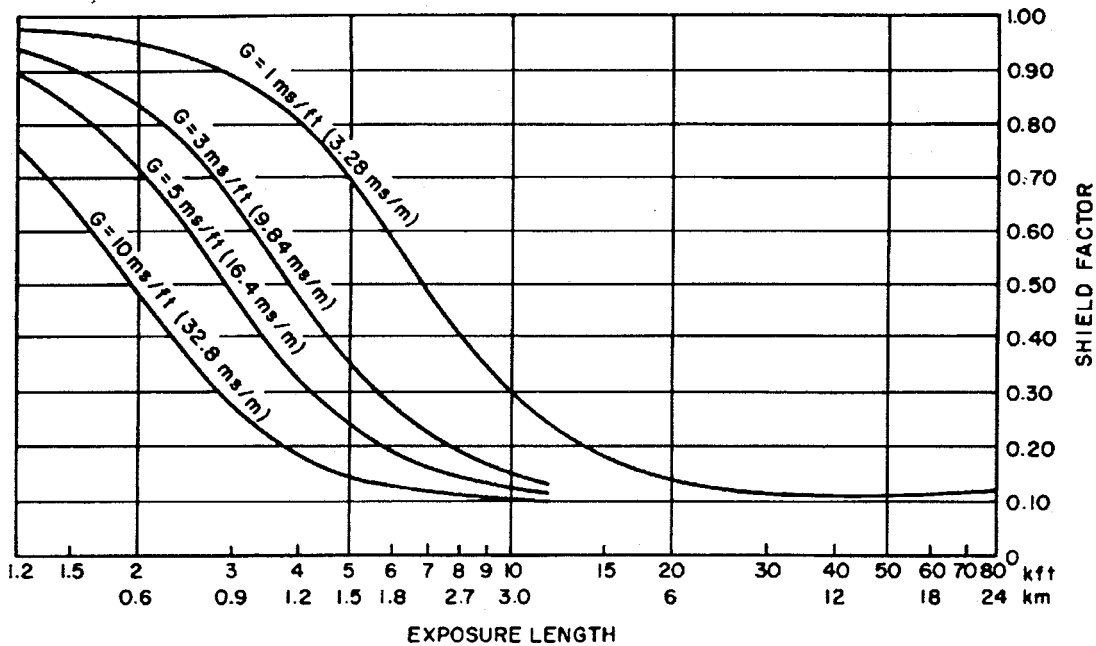

NOTE 1— G is the distributed leakage to ground (siemens).

NOTE 2—Self-impedance of shield (including supplemental bare wire) is equal to $0.0567 + j0.2765 \Omega/\text{kft}$ ($0.1860 + j0.9071 \Omega/\text{km}$).

NOTE 3—Mutual impedance between shield and bare wire is equal to $0.0168 + j0.2765 \Omega/\text{kft}$ ($0.0551 + j0.9071 \Omega/\text{km}$).

NOTE 4—The length of shielded cable beyond exposure is 100 ft (30 m).

Figure 40—Illustration of 60 Hz shield factors for buried telecommunication cable with continuous leakage

ground wire component at one end only. In some cases, the worst case could be a fault somewhat remote from the end of the exposure where the earth return component has reached a more constant value throughout the exposure.

Where there are several supply lines between the same terminal points, the circuits and the overhead ground wires provide paths toward and away from an L-G fault on one circuit. Determination of the inducing current is much more complicated than in the single circuit case of the single supply line.

6.11 Example 3: Double-ended supply feed

This example shows the calculations for a double-ended supply feed and a telecommunication line that consists of both shielded cable and open wire. The use of Figure 38, which gives correction factors for differences in line heights, is also shown.

Given a uniform inductive exposure between a supply and telecommunication line, as shown in Figure 39, which shows exposures AB and BC taken separately:

- S is the horizontal separation between supply and communication lines [50 ft (15 m)];
- ρ is the earth resistivity (316 $\Omega\cdot\text{m}$);
- I is the inducing current (see Figure 39);

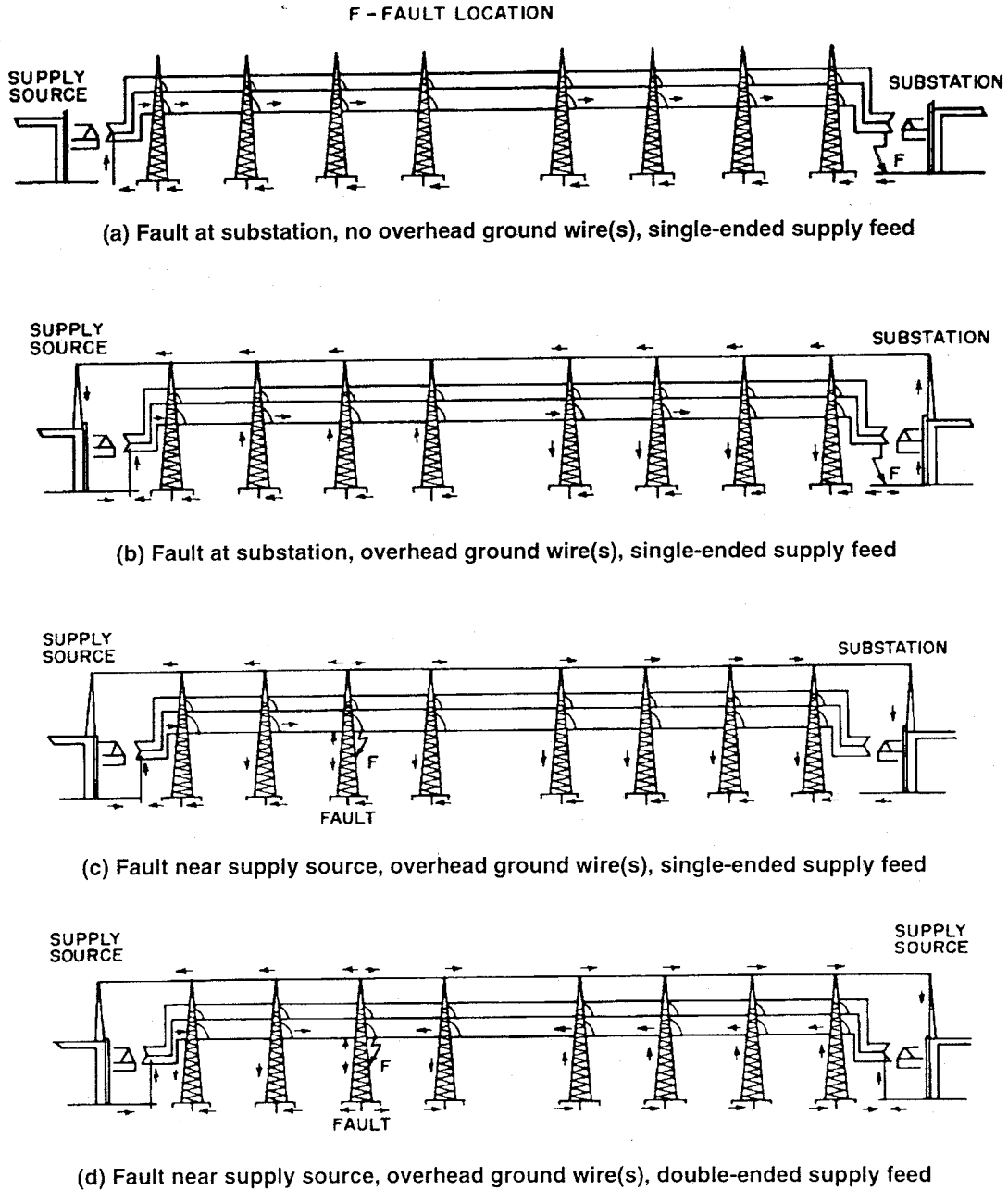

Figure 41—Examples of fault current distribution for line-to-ground faults

- D is the difference in line heights;
 exposure $AB = 50$ ft (15 m)
 exposure $BC = 15$ ft (4.5 m)
- L is the length of exposure;
 exposure $AB = 55$ kft (16.76 km)
 exposure $BC = 20$ kft (6.1 km)
- η is the shield factor (communication lines);

- exposure AB —shielded underground cable = 0.5
 exposure BC —open wire = 1.0
 z_m is the mutual impedance (complex) (Ω/kft or Ω/km);
 $|z_m|$ is the mutual impedance (absolute) (Ω/kft or Ω/km);
 Z_m is the mutual impedance (total) (Ω);
 V^s is the LI voltage with shielding.

The example is shown with S in feet and L in kilofeet (6.11.1–6.11.4), followed by S in meters and L in kilometers (6.11.5–6.11.8).

6.11.1 Exposure AB taken alone

$$R = 0.018 \Omega/\text{kft} \text{ (from Figure 28)}$$

$$X = 0.102 \Omega/\text{kft} \text{ (from Figure 29)}$$

The correction factor for X when D is equal to 50 ft and the horizontal separation is equal to 50 ft is $-0.0054 \Omega/\text{kft}$ (from Figure 38). X (corrected) is equal to $0.097 \Omega/\text{kft}$.

$$z_m = (0.018 + j0.097) \Omega/\text{kft}$$

$$L = 55 \text{ kft}$$

$$Z_{m(AB)} = z_m L = (0.018 + j0.097) 55 = 0.990 + j5.335 \Omega$$

$$I_1 \text{ (at } B') = 600 \text{ A}$$

$$\eta_{(AB)} = 0.5$$

$$V^s_{(AB)} = Z_m I_1 \eta = (0.990 + j5.335) 600 \times 0.5 = 297 + j1601 \text{ V}$$

$$|V^s_{(AB)}| = 1628 \text{ V}$$

6.11.2 Exposure BC taken alone

$$R = 0.018 \Omega/\text{kft} \text{ (from Figure 28)}$$

$$X = 0.102 \Omega/\text{kft} \text{ (from Figure 29)}$$

The correction factor for X when D is equal to 15 ft and the horizontal separation is equal to 50 ft is $0.0015 \Omega/\text{kft}$ (from Figure 38). X (corrected) is equal to 0.1035 or $0.104 \Omega/\text{kft}$.

$$z_m = (0.018 + j0.104) \Omega/\text{kft}$$

$$L = 20 \text{ kft}$$

$$Z_{M(BC)} = z_m L = (0.018 + j0.104) 20 = 0.360 + j2.080 \Omega$$

$$I_2 \text{ (at } B'') = 850 \text{ A}$$

$$\eta_{(BC)} = 1$$

$$V^s_{(BC)} = Z_m I_2 \eta = (0.360 + j2.080) 850 \times 1 = 306 + j1768 \text{ V}$$

$$|V_{(BC)}^s| = 1794 \text{ V}$$

6.11.3 Exposures AB and BC interconnected

Exposure *AB*:

$$Z_{m(AB)} = 0.990 + j5.335 \ \Omega$$

$$I_1 \text{ (at } C') = 500 \text{ A}$$

NOTE—The value of inducing current I_1 at C' is used because it is larger than the value of inducing current I_2 at A' .

$$\eta_{(AB)} = 0.5$$

$$V_{(AB)}^s = (0.990 + j5.335)500 \times 0.5 = 248 + j1334 \text{ V}$$

$$|V_{(AB)}^s| = 1357 \text{ V}$$

Exposure *BC*:

$$Z_{m(BC)} = 0.360 + j2.080 \ \Omega$$

$$I_1 \text{ (at } C') = 500 \text{ A}$$

$$\eta_{(BC)} = 1$$

$$V_{(BC)}^s = (0.360 + j2.080)500 \times 1 = 180 + j1040 \text{ V}$$

$$|V_{(BC)}^s| = 1055 \text{ V}$$

Exposure *AB* plus *BC*:

$$V_{(AC)}^s = V_{(AB)}^s + V_{(BC)}^s = (248 + j1334) + (180 + j1040) = 428 + j2374 \text{ V}$$

$$|V_{(AC)}^s| = 2412 \text{ V}$$

6.11.4 Exposures AB and BC interconnected with fault at B

From 6.11.1, the induced voltage for exposure *AB* is 1628 V (I_1 equals 600 A). From 6.11.2, the induced voltage for exposure *BC* is 1794 V (I_2 equals 850 A).

Because the inducing currents are 180° out of phase, the net LI voltage for exposures *AB* and *BC* interconnected with fault at *B* is

$$|V_{(AC)}^s| = |V_{(AB)}^s| - |V_{(BC)}^s| = 1628 - 1794$$

$$|V_{(AC)}^s| = 166 \text{ V}$$

6.11.5 Exposure AB taken alone

$$R = 0.06 \ \Omega/\text{km} \text{ (from Figure 31)}$$

$$X = 0.34 \Omega/\text{km} \text{ (from Figure 32)}$$

The correction factor for X when D is equal to 15 m and the horizontal separation is equal to 15 m is $-0.018 \Omega/\text{km}$ (from Figure 38). X (corrected) is equal to $0.322 \Omega/\text{km}$.

$$z_m = (0.06 + j0.322) \Omega/\text{km}$$

$$L = 16.76 \text{ km}$$

$$Z_{M(AB)} = z_m L = (0.06 + j0.322)16.76 = 1.006 + j5.397 \Omega$$

$$I_1 \text{ (at } B') = 600 \text{ A}$$

$$\eta_{(AB)} = 0.5$$

$$V_{(AB)}^s = Z_m I_1 \eta = (1.006 + j5.397)600 \times 0.5 = 302 + j1619 \text{ V}$$

$$|V_{(AB)}^s| = 1647 \text{ V}$$

6.11.6 Exposure BC taken alone

$$R = 0.06 \Omega/\text{km} \text{ (from Figure 31)}$$

$$X = 0.34 \Omega/\text{km} \text{ (from Figure 32)}$$

The correction factor for X when D is equal to 4.5 m and the horizontal separation is equal to 15 m is $0.004 \Omega/\text{km}$ (from Figure 38). X (corrected) is equal to $0.344 \Omega/\text{km}$.

$$z_m = (0.06 + j0.344) \Omega/\text{km}$$

$$L = 6.1 \text{ km}$$

$$Z_{m(BC)} = z_m L = (0.06 + j0.344) 6.1 = 0.366 + j2.098 \Omega$$

$$I_2 \text{ (at } B'') = 850 \text{ A}$$

$$\eta_{(BC)} = 1$$

$$V_{(BC)}^s = Z_m I_2 \eta = (0.366 + j2.098)850 \times 1 = 311 + j1783 \text{ V}$$

$$|V_{(BC)}^s| = 1810 \text{ V}$$

6.11.7 Exposures AB and BC interconnected

Exposure AB :

$$Z_{m(AB)} = 1.006 + j5.397 \Omega$$

$$I_1 \text{ (at } C') = 500 \text{ A}$$

$$\eta_{(AB)} = 0.5$$

$$V_{(AB)}^s = (1.006 + j5.397)500 \times 0.5 = 252 + j1349 \text{ V}$$

$$|V_{(AB)}^s| = 1372 \text{ V}$$

Exposure *BC*:

$$Z_{m(BC)} = 0.366 + j2.098 \ \Omega$$

$$I_1 \text{ (at C')} = 500 \text{ A}$$

$$\eta_{(BC)} = 1$$

$$V_{(BC)}^s = (0.366 + j2.098)500 \times 1 = 183 + j1049 \text{ V}$$

$$|V_{(BC)}^s| = 1065 \text{ V}$$

Exposure *AB* plus *BC*:

$$V_{(AC)}^s = V_{(AB)}^s + V_{(BC)}^s = (252 + j1349) + (183 + j1049) = 435 + j2398 \text{ V}$$

$$|V_{(AC)}^s| = 2437 \text{ V}$$

6.11.8 Exposures *AB* and *BC* interconnected with fault at *B*

From 6.11.5, the induced voltage for exposure *AB* is 1647 V (I_1 equals 600 A). From 6.11.6, the induced voltage for exposure *BC* is 1810 V (I_2 equals 850 A).

Because the inducing currents are 180° out of phase, the net LI voltage for exposures *AB* and *BC* interconnected with fault at *B* is

$$|V_{(AC)}^s| = |V_{(AB)}^s| - |V_{(BC)}^s| = 1647 - 1810$$

$$|V_{(AC)}^s| = 163 \text{ V}$$

7. Vectorial summation of a GPR with an LI voltage

Metallic telecommunication facilities that enter power stations may be subjected to a GPR when L-G faults occur on a power line associated with that station. The GPR from Clause 5 is equal to the product of the station ground grid impedance and that portion of the total fault current that flows through it.

A metallic telecommunication facility paralleling an electric supply line that experiences an L-G fault, in which fault current returns through earth, will have a voltage electromagnetically induced in that facility. The magnitude of such induction may be calculated as described in Clause 6.

A metallic telecommunication circuit may be subjected to the effects of both GPR and longitudinal induction arising from the same electric supply line fault current. The vectorial sum of these voltages, for both symmetrical and asymmetrical current waveforms, should be considered in the design of a safe and reliable telecommunication circuit.

Care should be taken to first determine the fault location that results in the greatest magnitude of the sum of the GPR and induced voltages. The fault location that results in the highest GPR does not necessarily cause the highest induced voltage.

NOTE—Further information can be found in IEEE Std 487-1992 on LI considerations for the telecommunication central office side of the HV interface facility.

7.1 Calculating the resultant voltage

This clause presents a method of calculating the resultant voltage between the electric power station ground grid and a conductor that is grounded at a remote location, such as a telephone central office. The combination of electromagnetic induction and power station GPR (before the application of protective devices) for both symmetrical and asymmetrical fault current waveforms is considered.

The following examples illustrate the proper combination of voltages that exist on a telecommunication wire line that is terminated at an electric power station. Figure 42a shows a telecommunication wire line serving a power station that is not the source of fault current. Figure 42b shows a telecommunication wire line serving a power station that is the source of fault current.

For simplicity, assume that the inducing current is also that creating the station GPR while flowing through the power station ground grid impedance.

7.1.1 Example 1: Symmetrical fault current

Given a telecommunication line serving a power station, as shown in Figures 42a and 42b, the power system data are as in 5.4.

I is the rms symmetrical fault current (inducing current) = 1186 $\angle 0$ A;

Z_{SG} is the local station ground impedance = 1.5 Ω ;

Z_m is the mutual impedance (total) = 0.185 + $j1.056$ Ω as in 6.4.1.1.

NOTE 1— Z_{SG} is taken purely as resistance for simplicity.

NOTE 2— Clause 5.4.3 calculates I_{peak} at 1186 $\angle -75.68^\circ$ A. For simplicity, refer fault current to $\angle 0$. As long as both the GPR and the induction calculations refer to the same angle, the results will be the same.

Assume a positive current direction, as shown in Figures 42a and 42b. By convention, positive voltage from negative to positive is indicated by the direction of voltage arrows. Polarities for V_g , V_s , and V_c are indicated on the diagrams of Figures 42a and 42b for a fault current in the direction shown. In Figure 42a, V_s equals $I Z_{SG}$, and V_g equals $-E$. In Figure 42b, V_g equals E and V_s equals $-I Z_{SG}$. The following calculations are based on Figure 42a, but the vector analysis is similar for both Figures 42a and 42b.

The longitudinal voltage, V_g , at point A of the telecommunication wire line is

$$V_g(\text{rms}) = -E(\text{rms}) = -I(\text{rms})Z_m = -1186 (0.185 + j1.056) = -(219 + j1252)\text{V}$$

The symmetrical value of power station GPR, V_s , at the station where the telecommunication wire line terminates is

$$V_s(\text{rms}) = Z_{SG}I = (1.5)1186 = 1779 \text{ V}$$

The phasor combination of induced voltage, V_g , and GPR, V_s , is

$$V_c(\text{rms}) = V_s(\text{rms}) - V_g(\text{rms}) = 1779 - [-(219 + j1252)] = 1998 + j1252$$

$$|V_c(\text{rms})| = 2358 \text{ V}$$

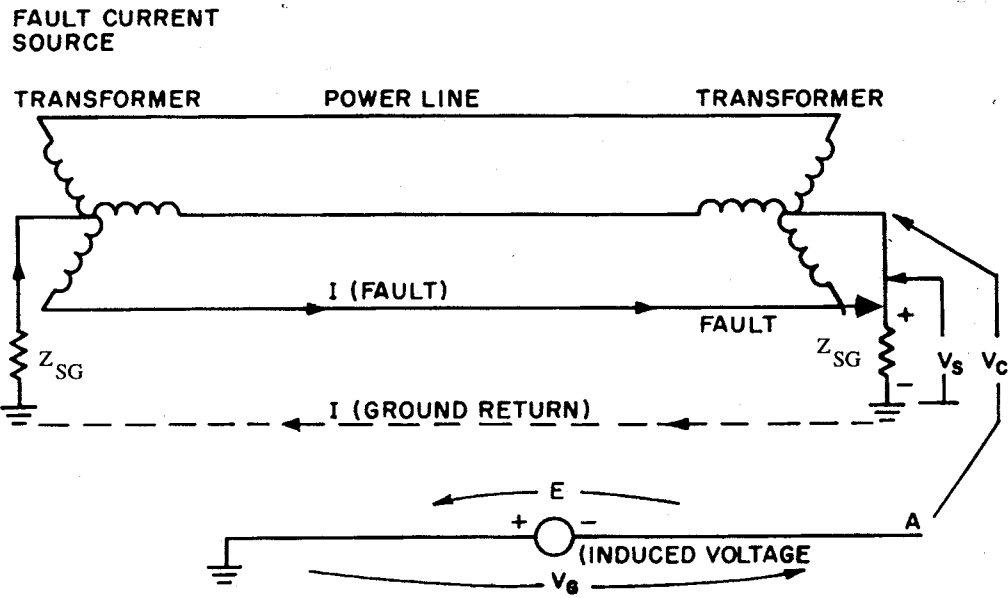

(a) Telecommunication wire line serving a power station that is not a source of fault current

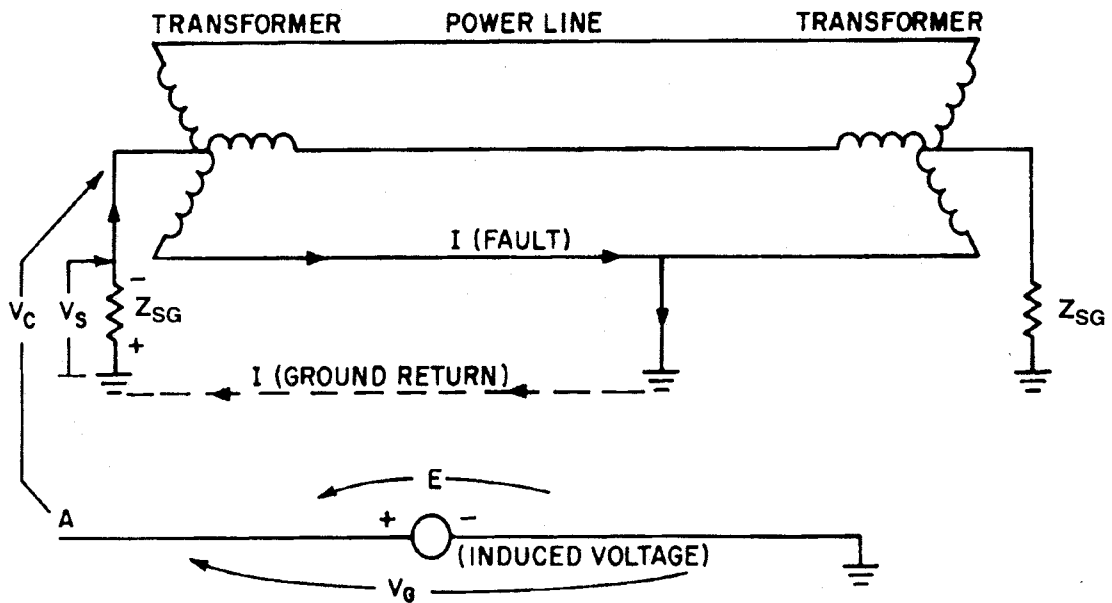

(b) Telecommunication wire line serving a power station that is a source of fault current

E is the LI voltage equal to $I Z_m$

Z_{SG} is the power station ground grid impedance

V_s is the power station GPR

V_g is the voltage from point A with respect to remote ground

V_c is the combination of induced voltage and GPR

Figure 42—Illustrations for Examples 1 and 2

$$|V_c(\text{peak})| = \sqrt{2}(2358) = 3335 \text{ V}$$

Fault impedance can be considered in the calculation of fault current and will reduce the GPR (V_s , Figure 42b) at the terminal station. Reduced fault current levels may reduce the induced voltage (E , Figure 42b).

In some instances, a telecommunication cable may be connecting two stations directly. Then the GPRs developed at both stations will be of opposite polarity, and their sum should be added to the induced voltage.

7.1.2 Example 2: Asymmetrical fault current

Given a telecommunication wire line serving a power station, as shown in Figure 42a, consider that the fault current returning through the power station ground impedance consists of an ac value and a decaying dc offset component. Take the case illustrated in 5.4.3, with a steady-state 60 Hz fault current of 1186 (rms) A and an initial dc offset equal to 1677 A. The X/R ratio of the power system is 3.9171 and the fault is 14.32° before the zero crossing of the phase-to-ground voltage, which produces the maximum dc offset (1677 A).

The power station GPR is the product of the instantaneous ground-return fault current and the power station ground impedance. Using the equation for current stated in 5.4.3,

$$V_s = Z_{SG}(i_{ac} + i_{dc})$$

$$V_s = Z_{SG}I(\text{peak}) \left[\sin\left(377t - \frac{\pi}{2}\right) + e^{-\left(\frac{t}{\tau}\right)} \right]$$

$$V_s = 1.5 \times 1186 \times \sqrt{2} \left[\sin\left(377t - \frac{\pi}{2}\right) + e^{-\left(\frac{t}{0.01039}\right)} \right]$$

$$V_s = 2516 \left[\sin\left(377t - \frac{\pi}{2}\right) + e^{-\left(\frac{t}{0.01039}\right)} \right]$$

where

$$\tau = L/R$$

The GPR is the sum of a sine wave voltage and a positive exponentially decaying dc voltage.

The sine wave and the dc term are of opposite polarity at $t = 0$. The maximum instantaneous value of the GPR voltage occurs at the approximate time when the sine wave reaches its first positive crest value. Thus, the maximum voltage occurs when

$$377t - \frac{\pi}{2} \cong \frac{\pi}{2}$$

or

$$t = 0.00833 \text{ s}$$

Accordingly, the maximum value of V_s is

$$\max |V_s| = 2516 \left[\sin \left(377 \times 0.00833 - \frac{\pi}{2} \right) + e^{-\left(\frac{0.00833}{0.01039} \right)} \right] = 2516 + 1128 = 3644 \text{ V}$$

The 60 Hz LI voltage, V_g , is

$$V_g = -E = -IZ_m$$

where

$$Z_m \text{ is } (0.185 + j1.056) = 1.072 \angle 80.06^\circ;$$

I is the inducing symmetrical fault current, $\sqrt{2}(1186 \angle -90^\circ) = 1677 \angle -90^\circ$. ($\sqrt{2}$ to convert to peak angle -90° for maximum dc offset);

$$V_g = -(1677 \angle -90^\circ)(1.072 \angle 80.06^\circ) = -1798 \angle -9.94^\circ = -1798 \angle -0.173 \text{ rad};$$

$$V_g = -1798 \sin(377t - 0.173) \text{ V (expressed as a function of time).}$$

The combination of induced voltage, V_g , and GPR, V_s , as a function of time is

$$V_c = V_s - V_g$$

$$V_c = 2516 \left[\sin \left(377t - \frac{\pi}{2} \right) + e^{-\left(\frac{t}{0.01039} \right)} \right] - [-1798 \sin(377t - 0.173)]$$

Combining the ac terms, at $t = 0$,

$$V_c = 2516 \angle -90^\circ + 1798 \angle -9.94^\circ$$

$$V_c = (0 - j2516) + (1772 - j301)$$

$$V_c = 1772 - j2817$$

$$V_c = 3328 \angle -57.83^\circ = 3328 \angle -1.0093 \text{ rad}$$

$$V_c = 3328 \sin(377t - 1.0093) + 2516 e^{-\left(\frac{t}{0.01039} \right)}$$

In this example, the maximum instantaneous value of the combination of induced voltage and GPR occurs as the sine wave approaches its first positive crest when

$$377t - 1.0093 \cong \frac{\pi}{2}$$

or

$$t \cong 0.00685 \text{ s}$$

and the maximum value of V_c is

$$\max |V_c| = 3328 \sin(377 \times 0.00685 - 1.0093) + 2516e^{-\left(\frac{0.00685}{0.01039}\right)} = 3328 + 1301 = 4629 \text{ V}$$

The dc offset value of fault current is not used in the calculation of the LI voltage because, in most cases, the di/dt values associated with the decay of the dc offset will be relatively low. In addition, omitting the induced effect of the dc offset value generally provides an upper bound for V_c , since any induction from the decaying offset current tends to oppose the polarity of the station GPR due to the dc offset current. The detailed analysis of this transient inductive phenomenon is beyond the scope of this recommended practice and would not offer a significant improvement in accuracy.

8. Power system fault current probability

Fault currents on an HV power system will vary randomly with location, duration, magnitude, and asymmetry. In addition, the configuration of most large power system networks is constantly changing.

The random character or nature of a fault, and the extremely low probability of a fault having maximum possible worst-case characteristics, make it economically and technically possible not to use ultimate or worst-case fault current calculations and conditions, allowing the use of a more realistic approach when determining the magnitude of interference into wire-line telecommunication facilities.

8.1 Probability analysis

If statistics, calculations, or measurements on fault currents for every location are available, probable maximum fault current magnitude and its characteristics can be adopted as the protection design values. When extensive data is not known, intelligent assumptions can be used and should be based upon previous histories of local conditions. It is highly improbable that a fault would occur at the worst location and have a full or ultimate transformer bank fault current magnitude that is fully offset and with a duration of ten cycles or more. Fault impedance, variations in soil resistivity, the influence of terminal equipment on the larger X/R ratios of a transmission line, and the point on the voltage waveform at a fault initiation rarely (if ever) being at zero, all combine to make the worst-case situation highly unlikely. A thorough analysis of this subject is beyond the scope of this recommended practice, but can be found in other publications (see Clause 13).

The conclusions that can be drawn are

- a) The magnitude and characteristics of the GPR or induced voltages, or both, are the result of the random events surrounding power system faults.
- b) A complex relationship exists between the random variables that contribute to the interference on telecommunication cables and facilities.
- c) Knowing the distribution laws of random variables, an interdependence between the possible values of interfering voltages and their respective probabilities can be established.
- d) The relationship deduced from incorporating power fault field data analysis allows a determination of the probability of an interfering voltage exceeding a predetermined permissible value under actual operating conditions. Less than worst-case values can then be assigned for an economical protective equipment design.
- e) The power utility should use probability studies to determine the magnitude, wave form, and duration of fault currents to be used in the interference calculations.

9. ZOI of GPR

9.1 Conductive interference

In the event of a fault in a section of an extensive electric power system, a current, I_e , will flow from the grounded fault through the earth and through the electric power station source grounding electrode, as shown in Figure 43a. Such a section of the system may be part(s) of substations, generating stations, or overhead transmission lines. The current flowing through the impedance of the source grounding electrode will produce a potential (GPR) relative to remote earth. The soil in the vicinity of the ground electrodes will also assume some potential relative to remote earth. There will also be a GPR produced at the location of the fault.

If a telecommunication grounding electrode or a buried cable without an insulating jacket over its metallic sheath is located in the vicinity of an HV electric power station, a transmission line tower, or enters an electric power station, a part of the GPR of the HV system, as shown in Figure 43a, is transferred to the electrode or sheath in the event of a fault to ground. The general calculations of Clause 7 show that a high sheath potential can result in dangerous step and touch voltages. A potential may also appear on the telecommunication circuits through the operation of the overvoltage protectors or as a result of a dielectric failure. If there is an insulating jacket around the cable, a high ground potential may puncture it. The transferred potentials are difficult to calculate accurately due to the nonhomogeneity of the soil, shield grounds in the GPR zone, shield impedance, and shield grounds in the remote earth area.

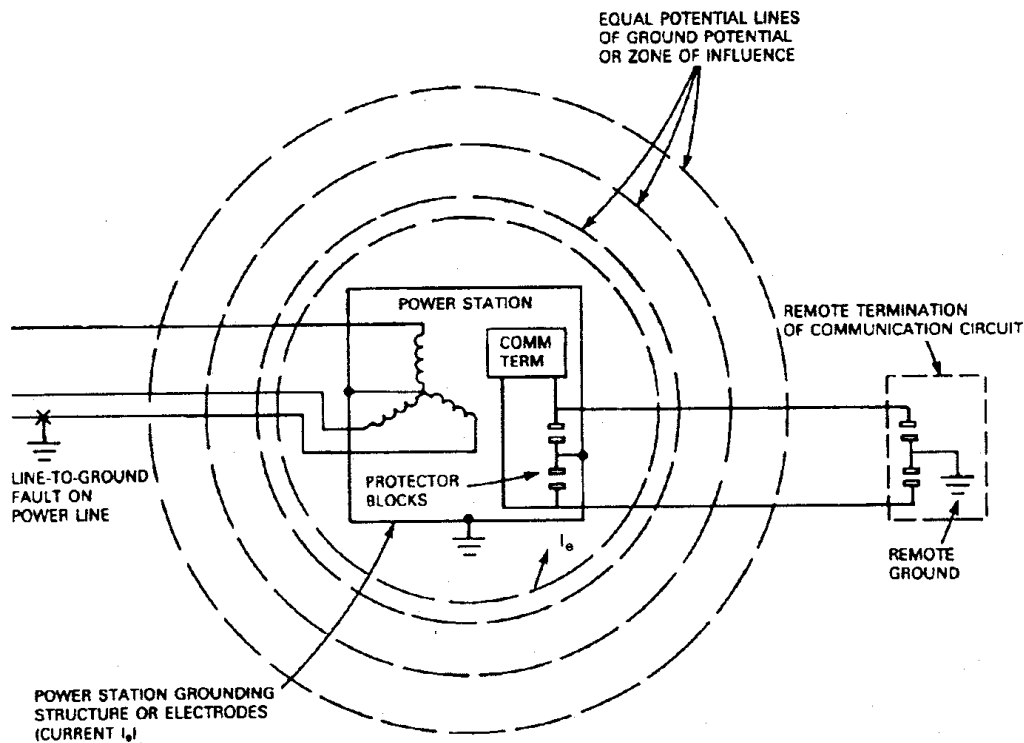

Figure 43a—Theoretical GPR ZOI

9.2 Equipotential lines

As a result of current flowing from the ground electrode(s) to earth and through the earth path, equipotential surfaces plotted at right angles to these current lines will assume a shape controlled by the path of the current. The density of the equipotential (potential gradients) surface(s) having equal voltage differences between them, across a path in a given direction, determines the interfering voltage that may be encountered (see Figure 44). This resulting potential will be higher near the grounding electrode, as shown in Figure 43b.

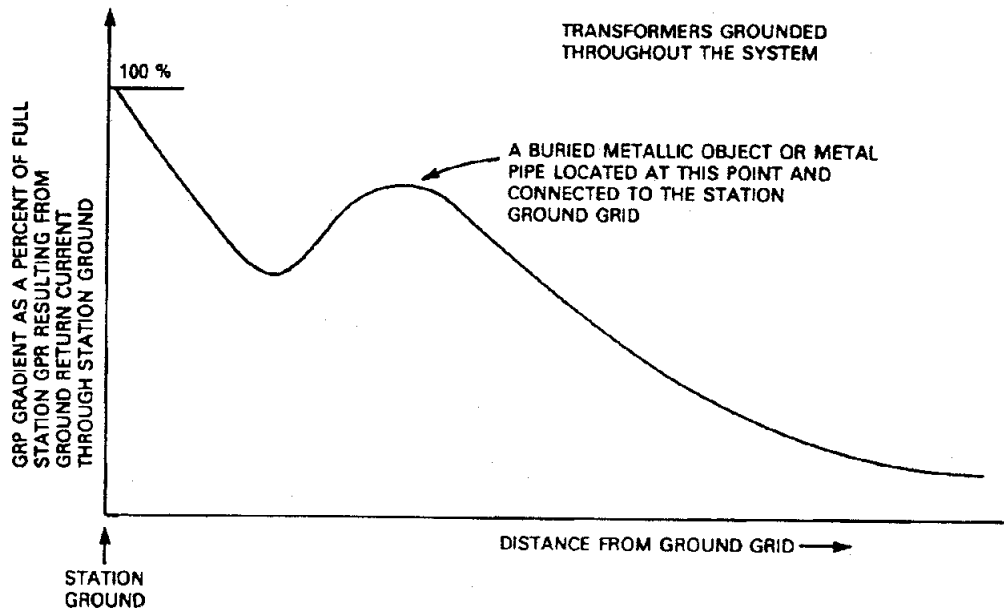

Figure 43b—Ground potential gradient

The theoretical ZOI depicted in Figure 43a assumes that the current density leaving or returning to the power ground is uniform. However, in reality, the current density surrounding the power ground will vary due to influence from a number of factors, thus distorting the equipotential lines. These influencing factors include

- a) Variations in soil resistivity
- b) Proximity effects of metallic objects such as buried pipes, buried conduit, railways, fences, etc.
- c) Overhead ground wires and/or multigrounded neutrals
- d) Magnetic effects of the power line supplying the fault current that varies with the ground fault magnitude

NOTE 1—Any one or a combination of the above can be the dominant influencing factor.

Therefore, the equipotential lines cannot be established simply by measuring impedance from the ground connection to various points around it. However, it is a good starting point and then, through visual inspections, items can be identified like those listed that can influence the shape of the equipotential lines and either avoid those areas or add a margin of area to the radial distance calculation for the ZOI.

Figures 43c through 43j illustrate theoretical GPR fall-off distributions with respect to remote earth for various ground grid and different earth resistivity models. These curves were developed using the EPRI (Electric Power Research Institute) program SGA. They do not take into account the effects of buried metallic objects that may be connected to, and act as an electrical extension of, the substation grounding grid. If these situations exist, the use of the fall-of-potential impedance measurements referenced in IEEE Std 81-1993 and IEEE Std 81.2-1991 to generate the proper curves for a specific grid is recommended.

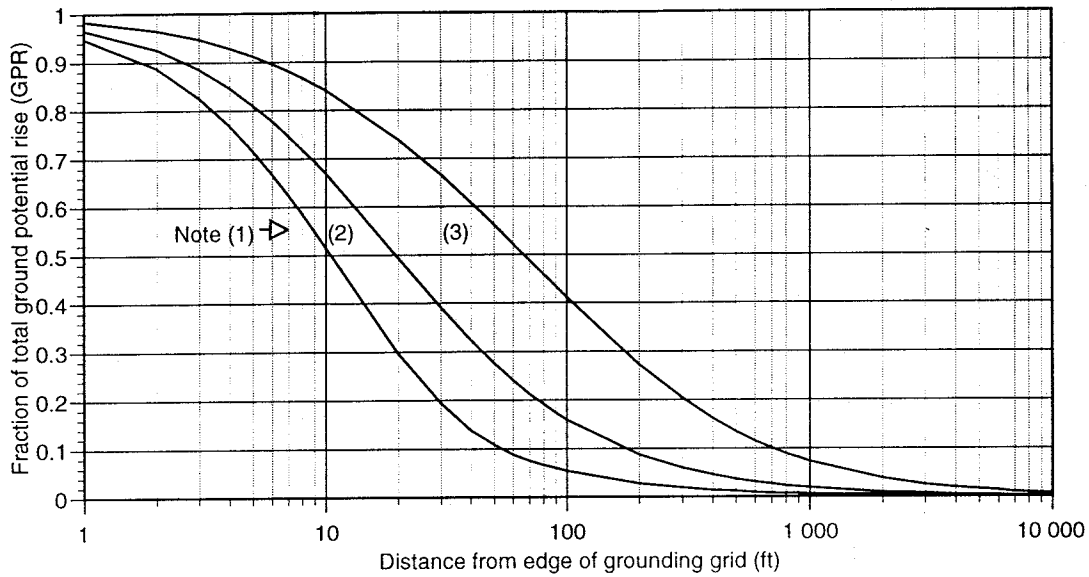

NOTE 1—Two-layer soil, 100/20 Ω -m (top layer is 20 ft in depth).

NOTE 2—Single-layer soil, 100 Ω -m.

NOTE 3—Two-layer soil, 100/1000 Ω -m (top layer is 20 ft in depth).

Figure 43c—Earth potential distribution from edge of power station grid with respect to a remote earthing point (1600 ft² grid)

NOTE 2—Additional information on the determination of the boundary of the ZOI is contained in 9.8.

Table 10 illustrates the geometry of the grounding systems used for the GPR fall-off distribution graphs. Each mesh consists of 4/0 AWG copper wires buried at a depth of 2 ft (0.6 m). Eight-foot (2.4 m) ground rods are at the corner of each mesh. For very large grids, the use of ground rods and mesh size in the center of the grid have little influence on ground grid resistance to earth or fall-off rate. In the 935 000 ft² (87 000 m²) grid, the outer two 60 ft (18 m) meshes consist of buried ground wires and ground rods placed at 30 ft (9 m). The inner meshes consist of ground wires at 60 ft (18 m). The ground rods were deleted from the inner meshes for the calculations.

Table 10—Geometry of grounding systems for Figures 43c–43j

| Figure | Ground grid (ft ² /m ²) | Number of meshes | Grid size (ft/m) |
|---------|--|------------------|------------------|
| 43c/43g | 1 600/150 | 8 × 8 | 5.0/1.52 |
| 43d/43h | 35 000/3 250 | 6 × 6 | 31.18/9.5 |
| 43e/43i | 290 000/27 000 | 18 × 18 | 29.92/9.12 |
| 43f/43j | 935 000/87 000 | 16 × 16 | 60.43/18.42 |

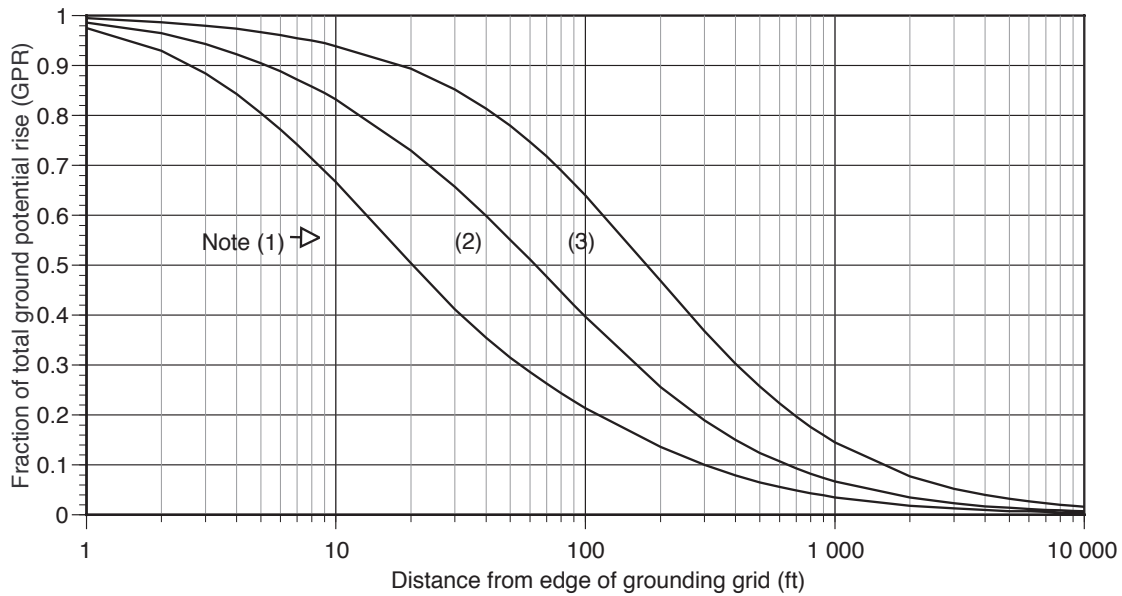

NOTE 1—Two-layer soil, 100/20 $\Omega\cdot\text{m}$ (top layer is 20 ft in depth).

NOTE 2—Single-layer soil, 100 $\Omega\cdot\text{m}$.

NOTE 3—Two-layer soil, 100/1000 $\Omega\cdot\text{m}$ (top layer is 20 ft in depth).

Figure 43d—Earth potential distribution from edge of power station grid with respect to a remote earthing point (35 000 ft² grid)

For each graph, a range of two layer soils are represented. Distances are given from the edge of the ground grid, where the protection requirements are usually specified. If the power utility has the substation fence tied to the ground grid, the area enclosed by the fence ground should be used. If the second layer of soil is more than 200 ft (60 m) in depth, the uniform soil model can be used. If the soil has greater extremes than used in the graph, the fraction of total GPR can be interpolated. For mild cases, linear interpolation is adequate. For severe cases, log interpolation should be used. For grid sizes that fall between the given graphs, log interpolation is recommended.

Table 11 presents some examples using the GPR fall-off distribution graphs. The assumption for these examples is that the GPR of the power station is 1000 V_{peak} and that the user wants to estimate the distance from the edge of a power station grid where the GPR has decreased to 300 V. The fraction of total GPR is equal to 300 V/1000 V = 0.3.

9.3 Potential contour surveys

A potential contour survey can be made to locate the hazardous potential gradients in the vicinity of grounded electrical structures for each fault type and location. The voltage drop to points surrounding the structure is measured from a known reference point and plotted on a map of the location. A potential contour map may then be drawn by connecting points of equal potential with continuous lines. If the contour lines have equal voltage differences between them, the closer the lines, the greater the hazard for step potential. Actual gradients due to ground fault current are obtained by multiplying test current gradients by the ratio of

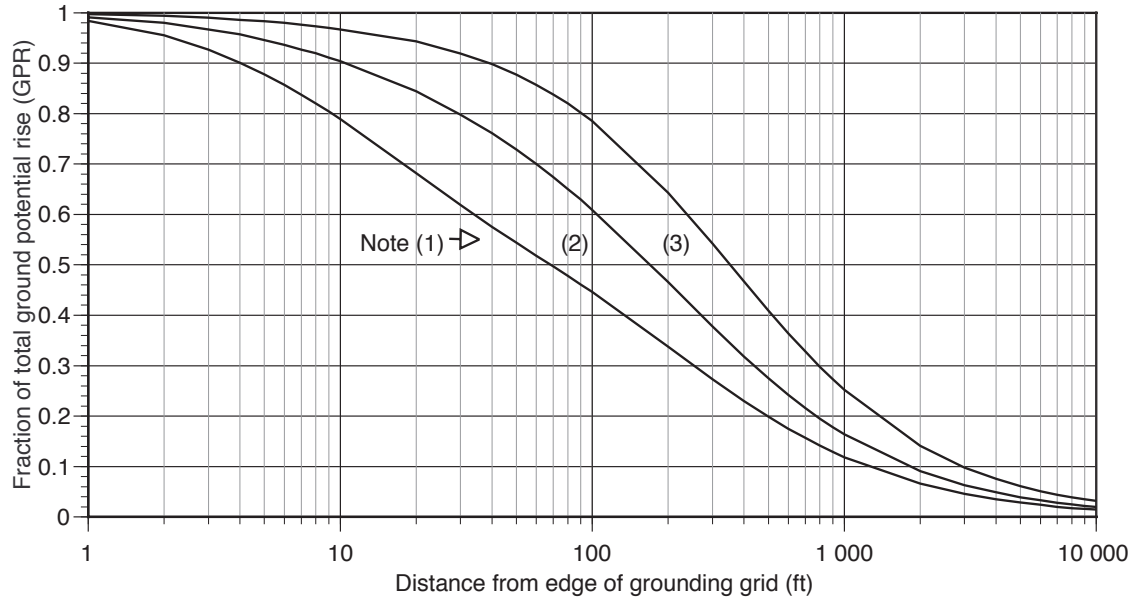

NOTE 1—Two-layer soil, 100/20 $\Omega\cdot\text{m}$ (top layer is 20 ft in depth).

NOTE 2—Single-layer soil, 100 $\Omega\cdot\text{m}$.

NOTE 3—Two-layer soil, 100/1000 $\Omega\cdot\text{m}$ (top layer is 20 ft in depth).

Figure 43e—Earth potential distribution from edge of power station grid with respect to a remote earthing point (290 000 ft² grid)

Table 11—Examples using GPR fall-off distribution graphs

| Example | Ground grid (m ² /ft ²) | Soil ($\Omega\cdot\text{m}$) | GPR (V) | Distance from edge of grounding structure to 300 V GPR location (m/ft) |
|---------|--|--------------------------------|---------|--|
| A | 3 250/35 000 | 100/20 | 1000 | 17/55 |
| B | 3 250/35 000 | 100/1000 | 1000 | 122/400 |
| C | 3 250/35 000 | 100/80 | 1000 | 31/103* 32/104† |
| D | 8 360/90 000 | 100/20 | 1000 | 27/90† |

*Linear interpolation.

†Log interpolation.

the fault current to test current. A typical contour map is shown in Figure 44. The area contained by the perimeter B in Figure 44 is termed the ZOI of the GPR. The permissible magnitude of the voltage along the perimeter B is by choice or design and is often limited, by agreement among the authorities concerned, to a maximum of 300 V.

The most accurate measurements of potential gradients are made using the volt-ammeter or current injection method. A known current, usually between 1 A and 100 A and usually between 55 Hz and 70 Hz, is injected

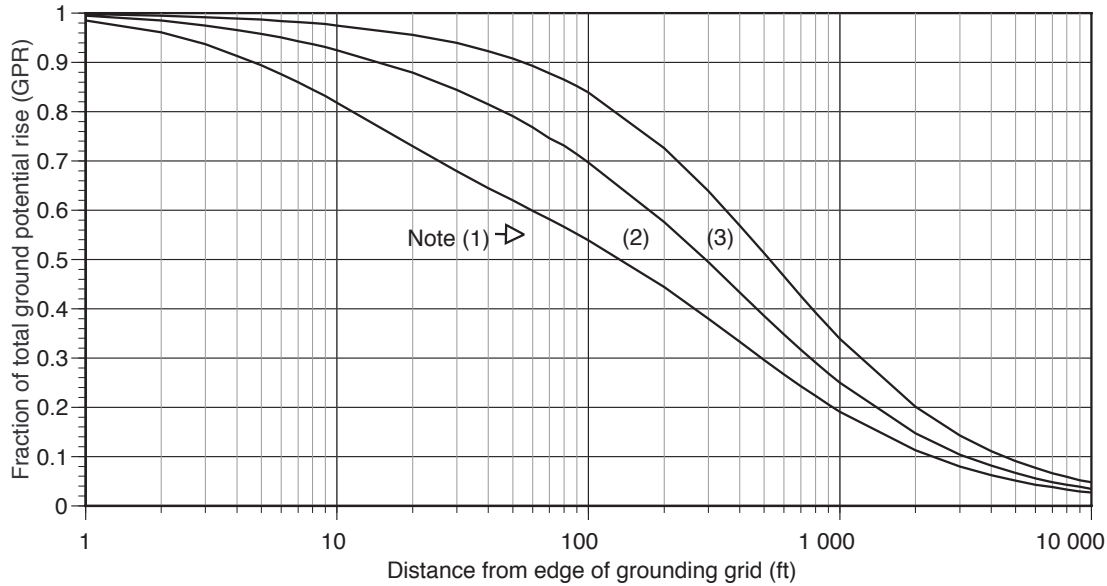

NOTE 1—Two-layer soil, 100/20 $\Omega\cdot\text{m}$ (top layer is 20 ft in depth).

NOTE 2—Single-layer soil, 100 $\Omega\cdot\text{m}$.

NOTE 3—Two-layer soil, 100/1000 $\Omega\cdot\text{m}$ (top layer is 20 ft in depth).

Figure 43f—Earth potential distribution from edge of power station grid with respect to a remote earthing point (935 000 ft² grid)

into a remote ground test electrode via an insulated conductor. A current greater than 50 A (personnel and equipment safety considerations should be observed) is preferred by some authorities, particularly where the ground impedance is less than 1 Ω . Where electronic measuring instruments are used (for example, a digital frequency selective voltmeter), a test current much less than 50 A is satisfactory. Where insulated overhead ground wires are employed and calculations would be required, this procedure would not apply. The current should be held constant during the test. A remotely located ground test electrode is necessary to prevent gradient distortion, caused by the mutual impedance of inadequately spaced ground electrodes. The distance between the ground under test and the remote current electrode may vary from less than 300 m, for a small ground grid or an isolated station, to a kilometer or more for larger installations and those in densely populated areas. Measurements of the potential should be made with a very high impedance meter connected between the ground grid and a test probe, which is driven into the earth along the profile lines radial to the power station. Unless suitable means are employed to mask out residual ground current and other interference, the test current should be of sufficient magnitude to do so. External power frequency and harmonic components are removed by filtering. At the same time, care should be taken to prevent heating and drying of the soil in contact with the ground grid or test electrode to avoid variations in voltage gradients during a series of measurements. Low-current test methods will produce approximate good results. Economics and the necessary or desired accuracy required will dictate the use of these or other methods and the number of measurements to be made (see IEEE Std 81-1983 and IEEE Std 81.2-1991).

When more than one overhead or underground cable is connected to a substation, potential gradients in and around the substation may be quite different for faults on different lines or cables. Likewise, faults at different locations in large substations may also result in differences in potential gradients in and around the power station. Potential gradients in and around a large substation should be determined for two or more fault conditions.

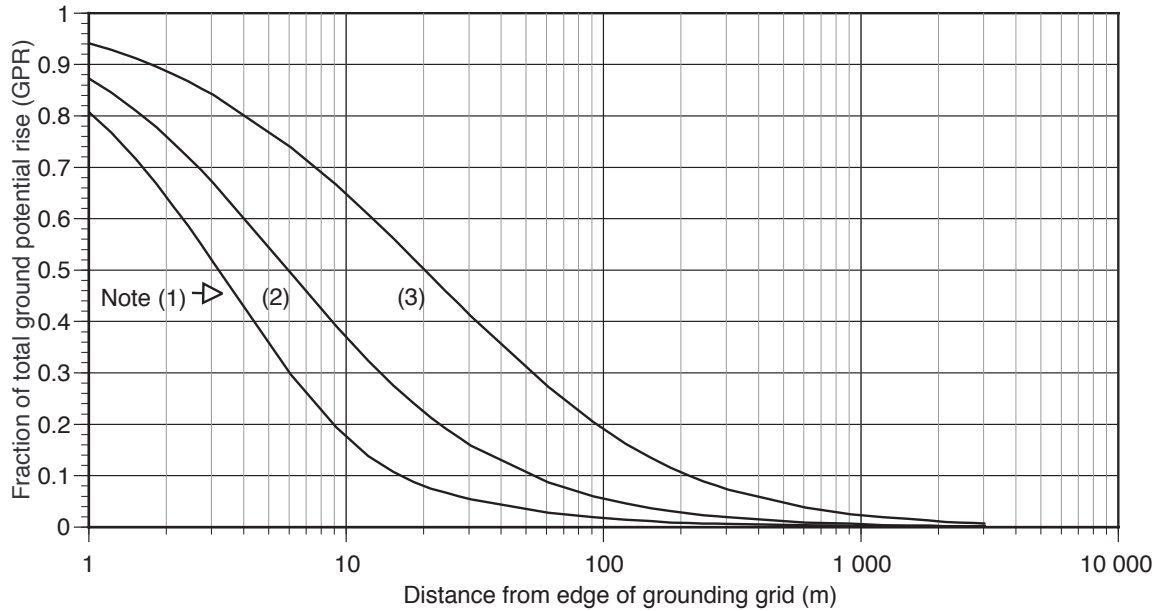

NOTE 1—Two-layer soil, 100/20 $\Omega\cdot\text{m}$ (top layer is 6 m in depth).

NOTE 2—Single-layer soil, 100 $\Omega\cdot\text{m}$.

NOTE 3—Two-layer soil, 100/1000 $\Omega\cdot\text{m}$ (top layer is 6 m in depth).

Figure 43g—Earth potential distribution from edge of power station grid with respect to a remote earthing point (150 m² grid)

Underground metallic structures, metallic structures on the surface of the earth, metallic fences, and overhead ground wires in the vicinity of a substation, whether connected to the ground grid or not, will usually have a significant effect upon potential gradients and should be considered when making potential gradient measurements. These structures include neutral conductors, metallic cable sheaths, metallic water and gas lines, and railroad rails. Gas pipe lines and power pipe type cables often have insulating joints with overvoltage devices for corrosion protection that are bypassed during a fault if a GPR occurs. These should be temporarily shorted out during tests.

When a potential gradient study cannot be justified economically, potential gradients may be calculated from ground resistance and soil resistivity measurements. The accuracy of such calculations will be dependent upon the accuracy of the measurements and the unknown abnormalities of the earth around and below the ground grid (see IEEE Std 81-1983). The adequacy of such calculations may then be verified with relatively few potential gradient measurements.

When a ground electrode or a buried cable of a telecommunication system is located in the vicinity of an HV ground grid, part of the potential arising in the latter during a ground fault can transfer to the former through resistive and inductive coupling. An HV metal tower or conductor that has fallen to the ground can also be regarded as a ground electrode in the same sense. The potential may enter the telecommunication circuit from the telecommunication grounding electrodes or cable sheath through the overvoltage protectors or due to a dielectric failure of the cable jacket or conductors.

9.4 Effects of GPR within the ZOI

Depending upon the magnitude of a GPR, the following effects may arise outside a power station or adjacent to a power line grounding electrode or transmission line tower (within the ZOI of the GPR):

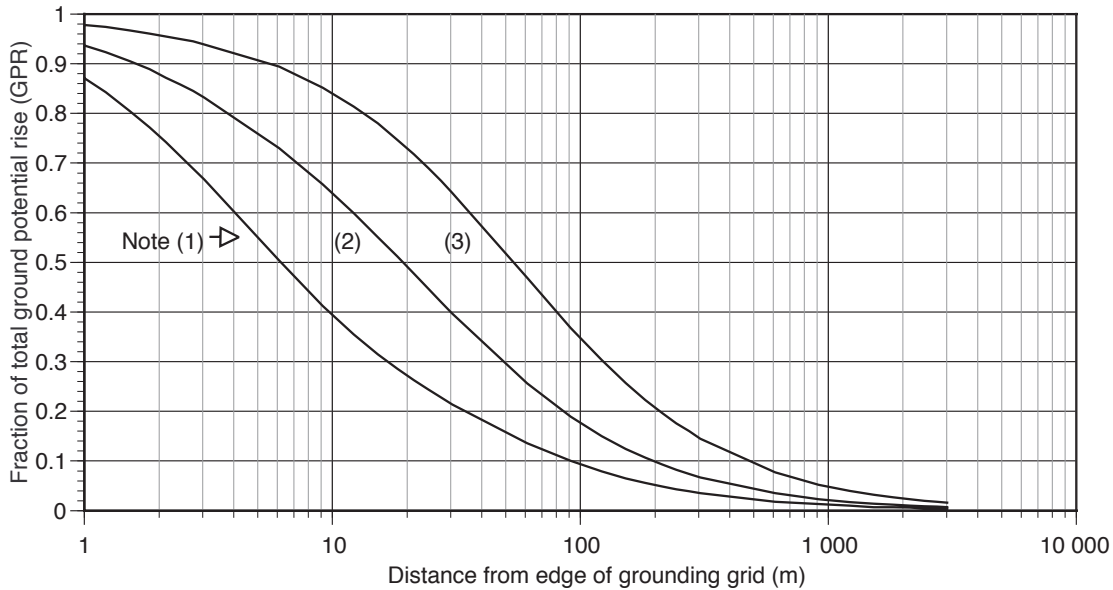

NOTE 1—Two-layer soil, 100/20 $\Omega\cdot\text{m}$ (top layer is 6 m in depth).

NOTE 2—Single-layer soil, 100 $\Omega\cdot\text{m}$.

NOTE 3—Two-layer soil, 100/1000 $\Omega\cdot\text{m}$ (top layer is 6 m in depth).

Figure 43h—Earth potential distribution from edge of power station grid with respect to a remote earthing point (3250 m² grid)

- a) The potential may be transferred through a metal part [bonded with, or coupled resistively to, the grounding electrode(s)] to remote locations.
- b) The touch voltage between a part grounded to the grounding electrode and a local ground (for example, an HV interface ground) may be excessive.
- c) Reversed touch voltage (or voltage stress) between the local ground and a part having a lower or even zero potential may become excessive; for example, a telephone cable protection interface.

9.5 Transfer of a GPR

The station ground potential can, for example, appear outside the ZOI through a conductor of a telecommunication line; a system-grounded neutral conductor of a lower voltage distribution system; a metallic sheath of a telecommunication or power cable; railway rails; and metallic pipes, such as water pipes, entering the station. The magnitude of this transferred GPR is somewhat lower than the station ground potential because of the longitudinal impedance of these cable sheaths, water pipes, rails, etc.

9.6 Determining the magnitude of the GPR in the vicinity of an electric power station or transmission line tower

An accurate calculation of equipotential lines may be impractical because of soil nonhomogeneity and irregularities in the electrode shape. The towers of power lines and the multigrounded neutrals of power distribution lines entering a station and connected in parallel with the station ground grid through the grounded overhead ground wires may cause an appreciable error. A reliable result can be obtained only by measurements at the station or line with all connections intact.

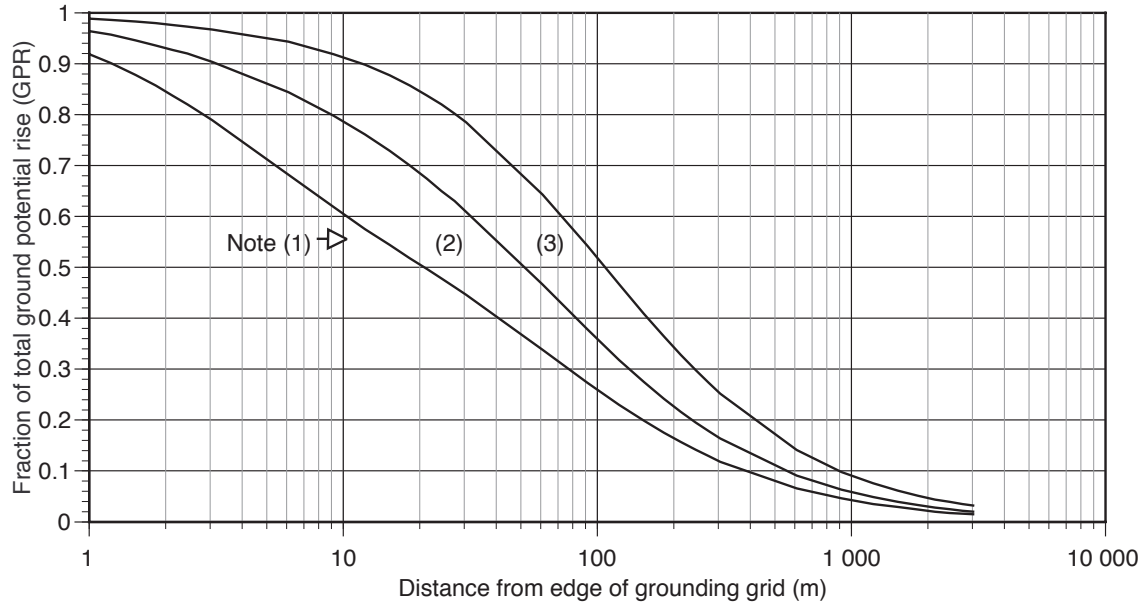

NOTE 1—Two-layer soil, 100/20 $\Omega\cdot\text{m}$ (top layer is 6 m in depth).

NOTE 2—Single-layer soil, 100 $\Omega\cdot\text{m}$.

NOTE 3—Two-layer soil, 100/1000 $\Omega\cdot\text{m}$ (top layer is 6 m in depth).

Figure 43i—Earth potential distribution from edge of power station grid with respect to a remote earthing point (27 000 m² grid)

In the design stage, some kind of evaluation is necessary. Measurements carried out at existing stations can give useful information for design estimations. If in calculations the average soil resistivity of an area is used, a ground grid can easily be approximated by a hemispherical or round plate electrode. The portion of the fault current returning through the shield wires of the power lines entering the station is important and should be considered. The distribution of fault current can easily be determined using a computer, if the tower footing impedances are known. The same is valid for faults along the power line.

The network composed of fully grounded overhead ground wires and towers of a power line entering a station represents an impedance to earth (Z_{ch} , as seen from the station) of

$$Z_{\text{ch}} \approx \sqrt{LZ_s Z_p}$$

where

- L is the span length;
- Z_s is the impedance of overhead ground wires per unit length;
- Z_p is the tower-footing impedance (assumed to be constant).

NOTE—This is true only for lines of infinite electrical length.

For steel overhead ground wires, Z_s approximately equals the dc impedance (for example, for two 50 mm steel wires, Z_s is equal to 2 Ω/km , and in the case of two similar ACSR overhead ground wires, Z_s is equal to 0.6 Ω/km (regardless of their size). Thus, in the case where L is equal to 0.3 km and Z_p is equal to 20 Ω , for two ACSR overhead ground wires, Z_{ch} is equal to 2 Ω . Other types of overhead ground wires have different

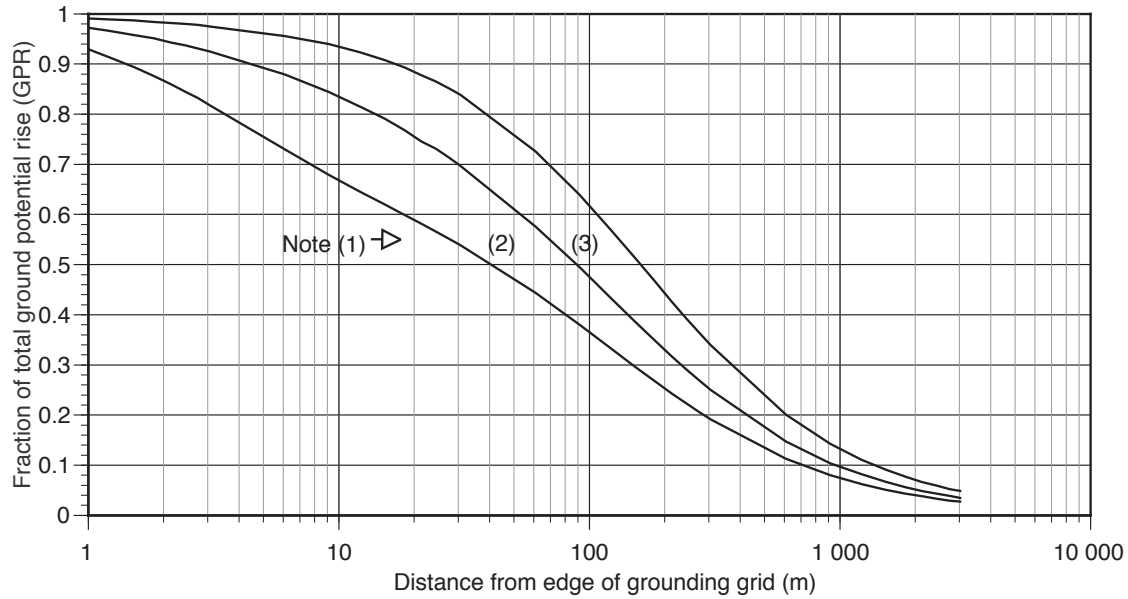

NOTE 1—Two-layer soil, 100/20 $\Omega\cdot\text{m}$ (top layer is 6 m in depth).

NOTE 2—Single-layer soil, 100 $\Omega\cdot\text{m}$.

NOTE 3—Two-layer soil, 100/1000 $\Omega\cdot\text{m}$ (top layer is 6 m in depth).

Figure 43j—Earth potential distribution from edge of power station grid with respect to a remote earthing point (87 000 m² grid)

values. Overhead ground wires, insulated or not and not bonded to the station ground, present a different network and should be evaluated in a different manner.

9.7 Cases

This subclause describes three conditions that may exist within the ZOI that are subject to GPR interference.

- a) Short noninsulated conductor
- b) Long noninsulated conductor
- c) Insulated conductor

9.7.1 Short noninsulated conductor within the ZOI and subject to a GPR interference

Assume that, apart from the power-system ground grid under consideration, there are no other metallic conductors in the soil, which is assumed to have a homogeneous resistivity. At a distance, d , which is more than three times the radius of the ground grid, the potential of the earth surface is in effect raised to the level

$$\varphi_e = \frac{\rho I_e}{2\pi d}$$

where

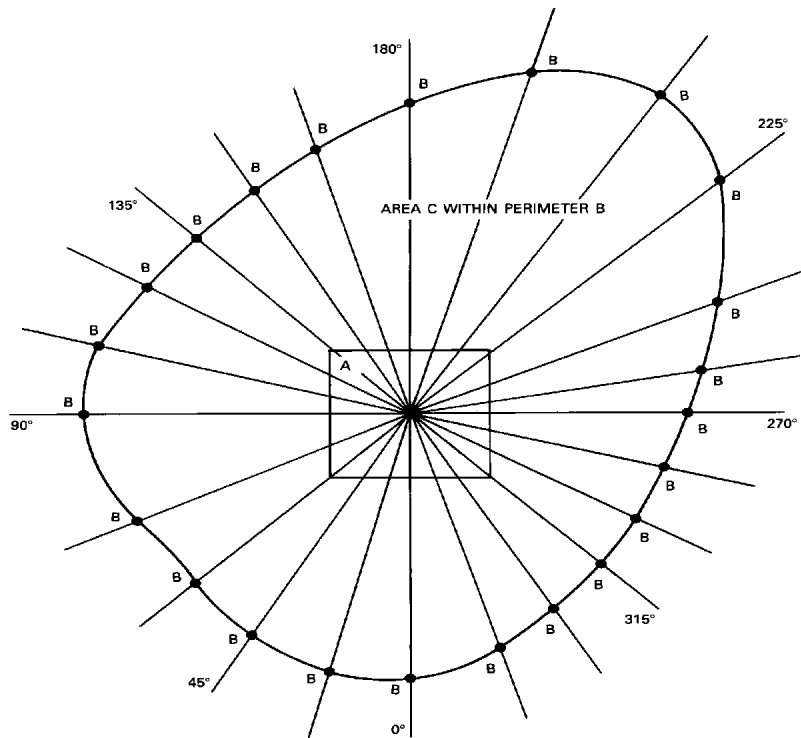

A is the power station ground grid

B are the points of equal value of ground resistance from station grounding grid where the GPR is reduced to an acceptable limit; for example, 300 V

C is the ZOI of the GPR

Figure 44—Potential contour of the GPR ZOI

φ_e is the potential of the surface of the earth;

ρ is the soil resistivity ($\Omega \cdot \text{m}$);

I_e is the fault current through grid (A);

d is the distance (m).

Also assume that a relatively short noninsulated conductor (for example, a section of the lead sheath of a telecommunication cable) is embedded in the soil near the current-discharging ground grid.

In the past, the conductive interference into such conductors was often measured in an electrolytic tank. Figure 45 shows typical potential curves thus determined for the earth surface in the vicinity of an overhead line tower ground. In the past, a tower ground electrode was assumed to take the form of a conductive hemisphere of the same impedance to remote earth, which was buried in the soil. This hemispherical electrode, indicated at the bottom left in Figure 46, and the conductor subject to interference were simulated in an electrolytic tank. For example, a noninsulated conductor of 600 m length, whose center part was immediately opposite the tower at a distance of 25 m, assumed a potential of between 3% and 5% of the earth electrode voltage (curve b in Figure 45).

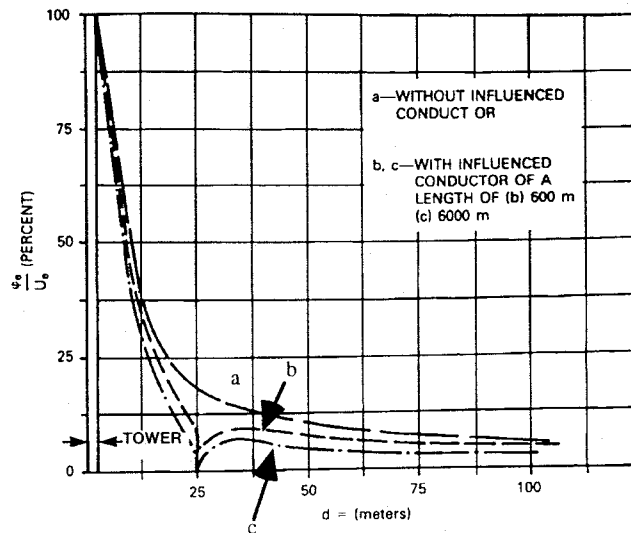

NOTE—(See also Figure 48.) Earth surface potential, ϕ , referred to the ground grid voltage, U_g , as a function of distance d from the tower center. The distance of the conductor from the tower center is 25 m.

Figure 45—Conductive interference in a bare metallic conductor embedded in the soil caused by a tower ground grid

Normal practice is to use computer programs to determine the conductive interference of conductors within the ground grid area of grounding systems.

The potential appearing on the cable shield, expressed as a percentage of the tower footing voltage, is shown in Figure 47 for various lengths and positions of the shield, subject to interference. Some of the curves shown on the left-hand side of Figure 47 were determined using an electrolytic tank; others by using a computer program. The curves on the right-hand side were determined using a computer program.

The computer program was used to calculate the discharged and absorbed currents per length of the electrode sections, as shown in Figure 47. This method was also used to calculate the currents in the corner footings of the tower and in the influenced conductor.

To be able to calculate the currents discharged and absorbed per conductor length, equations meeting the following conditions should be developed:

- a) The parts connected directly to the tower should discharge currents per length such that they assume a potential, relative to remote points, equal to the earth electrode voltage.
- b) For the conductor subject to GPR interference, the potential with respect to remote earth is not known, but it discharges as much current as it absorbs.
- c) The computer program used for Figure 47 assumed that the entire conductor subject to interference was at the same potential; that is, the voltage drop in the conductor was initially neglected.

The curves shown in Figure 48 indicate the computed current, that is, the current absorbed or discharged per length of the earth electrode. There is a current absorption zone close to the interfering earth electrode system and a current discharge zone from a certain distance onwards. Absorbed current is shown in Figure 48 as

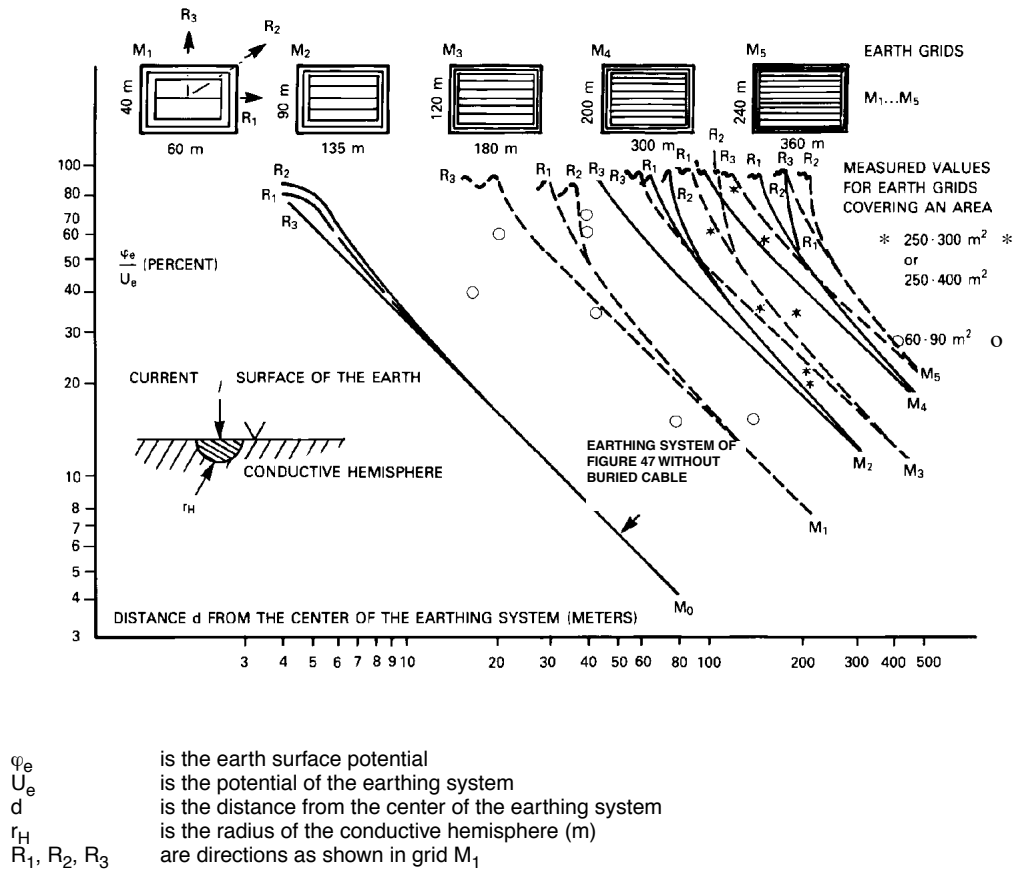

Figure 46—Relative potential of the surface of the earth in the vicinity of earth grids and in the vicinity of a tower footing with ring electrode

a negative current per length and discharged current as a positive current per length. Since the potential of a conductor subject to interference lies between the maximum and minimum potentials of the ground without this conductor, the earth potential not subject to interference is of interest for a rough estimation.

The curves in Figure 46, determined by means of a computer program, agree well with the values obtained for actual installations of the same size by using the current injection method. In the case of very large substations, there is usually a voltage drop between the fault point and the edge of the grounding system.

The curves shown in Figure 46 can be extended to the right. The grounding system should then be replaced by conductive hemispheres of radius r_H (Figure 46, bottom left). For large values of r_H , the following expression then applies:

$$\frac{\varphi_e}{U_e} = \frac{r_H}{d}$$

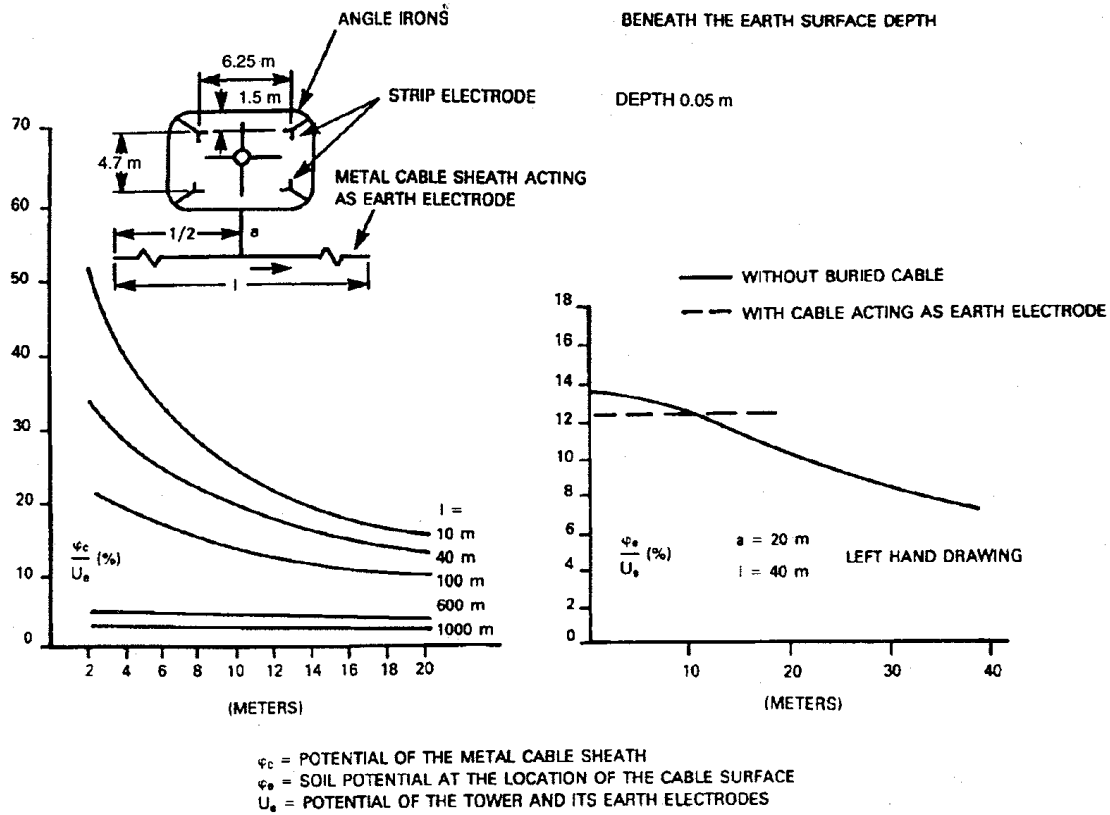

(a) $\phi_c/U_b = f(a)$

(b) $\phi_a/U_b = f(x)$

Figure 47—Conductive interference between the earthing system of a power line tower and the metallic sheath of a telecommunication cable as influenced conductor

9.7.2 Long noninsulated conductor within the ZOI and subject to interference

The potential at the various points of a long conductor subject to interference shows substantial differences, because the currents flowing between the absorption range and the discharge range cause considerable voltage drops. This problem is considered in other literature (see Clause 13).

For instance, consider a telecommunication cable that, in the area where it crosses under a power line, is embedded in the soil and has a noninsulated metallic sheath. Outside the crossing area, the cable is suspended in air and has a metallic shield. An equivalent diagram (Figure 49) takes into account the impedance per length of the metallic sheath and shield.

The variable E in Figure 49 represents the earth potential of the nearest point of the metallic cable sheath subject to interference (point 1 of the equivalent circuit) under the condition of no current absorption in the metallic sheath. When the metallic sheath of the crossing sheath is connected to the metallic shield of the cable suspended in air on either side of the crossing, a current enters the metallic sheath via the impedance R_{e1} .

The potential of the cable sheath at point 1 in Figure 49 can be expressed as follows:

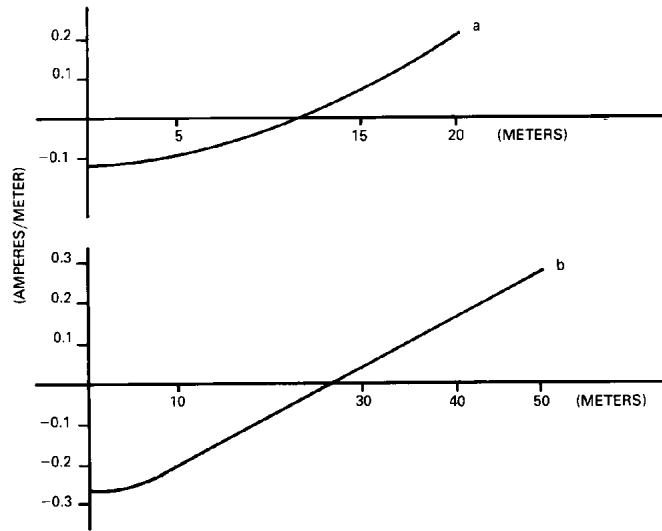

(a) $l = 40$ m

(b) $l = 100$ m

Figure 48—Approximate value of the current absorbed and discharged per length by the conductor metallic sheath of cables subject to interference

$$E_1 = \frac{Z_c E}{R_{e1} + Z_c}$$

where

$$\frac{1}{Z_c} = \frac{1}{Z_a} + \frac{1}{Z_b}$$

The leakage per length of a conductor subject to interference is not always easy to determine even if the soil resistivity is known. For instance, the leakage per length of the conductor is different near the ground grid area of the conductor. The leakage per length can be determined by dividing the amount of current absorbed per length (Figure 48) by the potential of the ground electrode subjected to interference. The current discharged per length attains a maximum in the case of a long conductor of higher impedance per unit length in the area of current discharge, that is, in the zone remote from the power system earth electrode.

The potential determined for a 600 m long grounded conductor electrode subjected to interference (as in Figure 47), whose ends are about 300 m from the power system earth electrode, is indicated in Figure 50. Curve b of Figure 50 applies for a lead cable sheath with a high impedance per length, and curve c applies for such a sheath with lower impedance. The more the potentials approximate those of the soil, not including an affected conductor, the higher the impedance per length of the conductor thus affected. To determine more accurately the influence of the impedance per length, an improved computer program is used that differs from that used for Figure 47 by assuming the potential of the affected conductor is not constant. The amounts of current absorbed or discharged per length of the affected conductors were calculated assuming that the current $I(x)$ flowing through the affected conductor causes a complex voltage drop between the points x_A and x_B of the conductor.

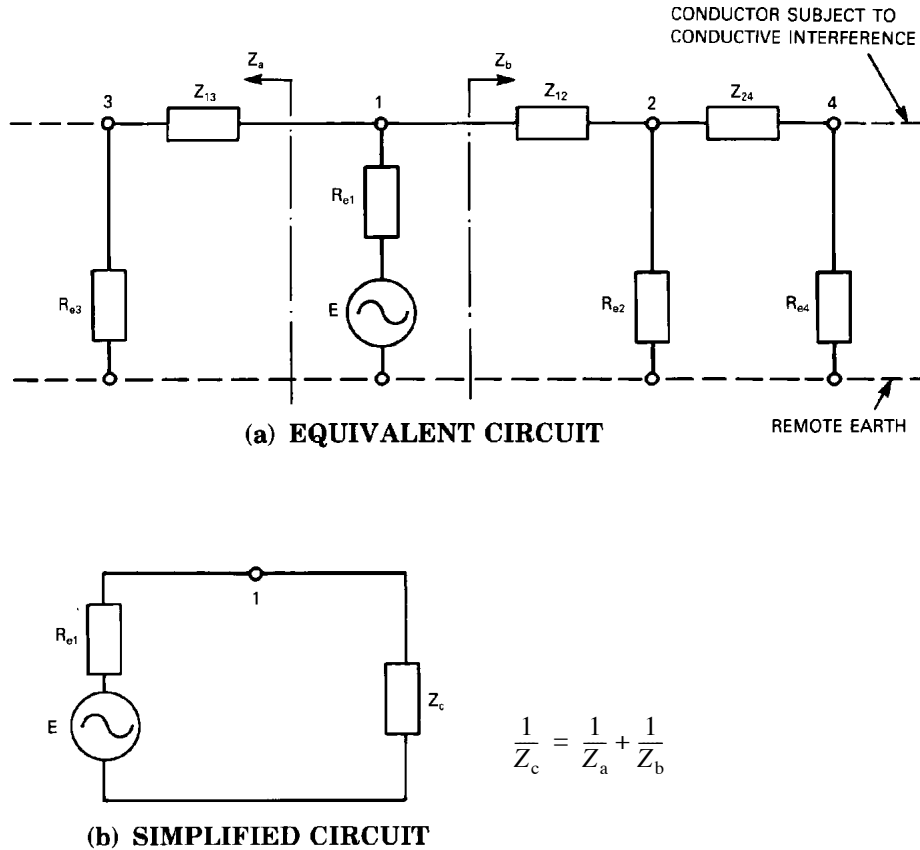

Figure 49—Circuits for calculating potential transferred to another earth electrode

$$U_{AB} = \int_{x_A}^{x_B} I(x)z dx$$

where

U_{AB} is the voltage drop between the points x_A and x_B of the conductor;
 z is the impedance per length.

The curved characteristics of the current per length may be replaced by a chord or a stepped characteristic, as already done in the case of the simplified program mentioned previously. The potential curves do not change if the impedance per length, z , and the soil resistivity, ρ , are multiplied by the same factor. The curve when z is equal to $6 + j6.7 \Omega/\text{km}$, and ρ is equal to $100 \Omega \cdot \text{m}$ applies when z is equal to $0.6 + j0.67 \Omega/\text{km}$ and ρ is equal to $10 \Omega \cdot \text{m}$.

9.7.3 An insulated conductor within the ZOI and subject to interference

The curves, as shown in Figure 46, are also of interest if the conductors laid in the vicinity of the power system earth electrodes or grid have an insulating outer jacket. The potential of the soil is not affected by these

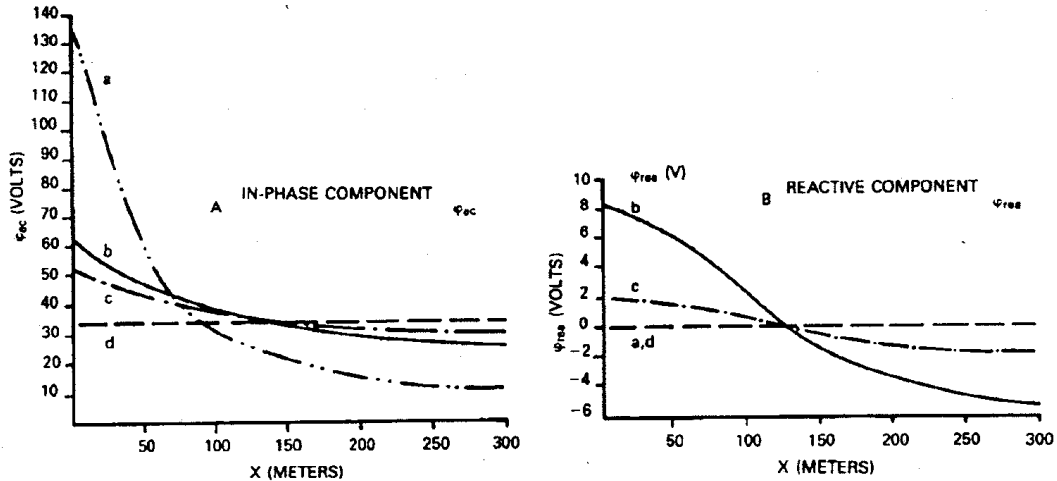

| CURVE | z Ω/km | ρ Ωm |
|-------|----------------------------------|-------------------------------|
| a | $ z \rightarrow \infty$ | OPTIONAL FINITE VALUE |
| b | $6 + j6.7$ $0.6 + j0.67$ | or = 100 etc. 10 |
| c | $1.32 + j1.23$ $2.64 + j2.46$ | or = 100 etc. 200 |
| d | 0 | OPTIONAL |

Figure 50—Potential of a 600 m influenced conductor (according to Figure 47) at 1000 V interfering earth electrode voltage

conductors. If the conductors, or a metal shield under the insulating jacket, are grounded outside the ZOI of the tower or station ground grid(s), either directly or via capacitance to earth; the potential of the soil is unaffected by the cable jacket and the insulation is stressed to the full potential. This applies in the case of purely conductive interference considered here.

A typical situation may exist where a power station ground grid and a telecommunication ground electrode (metallic pedestal, for example) are conductively coupled by a 0.1Ω mutual resistance. The resistance of the power system grid is 1.0Ω and the resistance of the telecommunication electrode is 45Ω . If 5000 A flow through the power station ground grid, a 5000 V GPR exists at the power station, and the pedestal is at a point where the voltage to remote earth is 500 V. Also assume that the metallic shield of a buried telecommunication cable with an outer insulating jacket connects the pedestal to remote earth outside the ZOI. The resistance of the cable shield and the remote earth electrode system is assumed to be 5Ω .

During the fault, approximately 10 A of current will flow from the pedestal ground along the cable shield to remote earth. The cable shield potential at the pedestal with respect to remote earth is 50 V. During the fault, there will be a GPR of approximately 450 V around the pedestal. Note the importance of the cable shield

continuity in reducing the voltage between the shield and the conductors within the core of the cable. Similar analysis can be done for actual cables connected to ground by anchor rods in the ZOI.

Manholes with several large-size insulated telecommunication cables are sometimes located in the ZOI. The voltage to remote earth of the metallic shield and interconnected manhole hardware is the product of the current picked up through the earth and the parallel impedance of all cable shields to remote earth. Common bonding of shields and hardware equalizes potentials inside the manhole. A GPR will exist outside the manhole.

9.8 Determination of the boundary of the ZOI

Computation of earth surface potentials based upon the station GPR should include serious consideration of

- a) *Grid density.* A few large grid meshes forming the ground grid will result in a higher station ground impedance and subsequently a higher GPR than the same ground grid with many more smaller grid meshes.
- b) *Vertical changes in soil resistivity.* As an example, a thin surface layer of high resistivity soil may increase the station ground grid impedance and result in a higher GPR.

There are also a number of minor factors affecting the ZOI. Lateral changes in soil resistivity are often less pronounced than vertical changes; therefore, calculations on averaged field measurements produce satisfactory results. Buried pipes or multigrounded neutrals may produce localized disturbances and, in urban areas, their mesh-like layout normally reduces the surface potential. In rural areas, neutral potentials can be modeled by a ladder network of longitudinal earth return impedances and transverse ground rod impedances. Irregularly shaped ground grid systems and seasonal variations in soil resistivity values may also affect the ZOI to a minor extent. However, assuming a fairly symmetrical earth electrode system that is reasonably isolated from other grounds, simple calculations can be used that should provide the accuracy required for a practical engineering solution.

NOTE 1—The equations that follow were developed from a simplified model and should not be expected to provide accurate ZOI boundaries for station ground grids with any degree of complexity. However, computer programs exist that can be utilized to calculate more accurately the substation ground impedance, the GPR, and the ZOI of the GPR.

Apart from the power station ground grid under consideration, assume there are no other metallic conductors in the soil. At a distance x , which is more than three times the radius of the station ground grid (modeled as a hemispherical electrode), the potential of the earth surface is in effect raised with respect to remote earth to the level

$$V(x) = \frac{\rho I_g}{2\pi x} \quad (26)$$

where

- $V(x)$ is the earth potential with respect to a remote location (V_{rms});
- ρ is the resistivity for uniform soil ($\Omega \cdot m$);
- x is the distance from the center of the ground grid (m) ($x \geq 3r$, r is the station ground grid radius);
- I_g is the rms station ground current (A).

For distances closer than three times the radius of the station ground grid, the spherical electrode of Equation (26) can be modified for a disk-like electrode in uniform soil, as illustrated in Equation (27).

$$V(x) = \frac{\rho I_g}{2\pi r} \sin^{-1} \left(\frac{r}{x} \right) \quad (\text{rad}) \quad (27)$$

where

r is the radius of a circle equal in area to the grid (m).

At a distance of three times the radius of the station ground grid, Equation (26) has an inaccuracy of approximately 2% when compared to Equation (27). The closer one approaches the station, the less accurate equation (26) becomes compared to Equation (27). At a distance greater than three times the radius of the station ground grid, both Equations (26) and (27) will provide identical results.

Thus, to avoid confusion as to which equation to use depending on the distance from the station, it is strongly recommended that Equation (27) be used at all times.

Equation (27) could be used directly if I_g is known, but $V(x)$ has often been related to the station GPR. Derived from Laurent and Niemann formula (IEEE Std 80-1986),

$$GPR = \frac{\rho I_g}{4r} + \frac{\rho I_g}{L} \quad (28)$$

where

L is the total length of buried conductor (m).

NOTE 2—Other expressions for GPR in terms of I_g may be available.

In Equation (28), the first term accounts for the GPR of a solid circular plate electrode of radius r . The second term provides a correction for the open mesh nature of the grid with the relative correction approaching zero for very dense grids (L is much greater than r). Combining Equations (27) and (28) gives

$$\frac{V(x)}{GPR} = \frac{0.064}{1 + 4r/L} \sin^{-1} \left(\frac{r}{x} \right) \quad (\text{rad}) \quad (29)$$

The $(1 + 4r/L)$ factor varies with the grid density.

The above is applicable for selecting a boundary of any selected voltage $V(x)$. To incorporate safety considerations for humans into Equation (29), it is necessary to set voltage limits below which the individual may receive a shock but will not experience ventricular fibrillation.

From IEEE Std 80-1986, the tolerable touch voltage (V_{touch}) is defined as

$$V_{\text{touch}_{50}} = (1000 + 1.5C(h_s, K)\rho_s)0.116/\sqrt{t_s} \quad \text{for 50 kg body weight}$$

$$V_{\text{touch}_{70}} = (1000 + 1.5C(h_s, K)\rho_s)0.157/\sqrt{t_s} \quad \text{for 70 kg body weight}$$

where

C is a reduction factor for derating the nominal value of surface layer resistivity and is a function of h_s and K ;

- h_s is the thickness of the crushed rock (m);
 K is a reflection factor;
 ρ_s is the resistivity of the surface material ($\Omega \cdot m$);
 t_s is the duration of shock current (s).

Assuming t_s equals t , which equals the power fault duration (s), refer to Clause 11:

- C is 1 for crushed stone resistivity equal to soil resistivity;
 ρ_s is the soil resistivity beneath a worker's feet ($\Omega \cdot m$).

$$V_{\text{touch}_{50}} = \frac{116 + 0.17\rho_s}{\sqrt{t}} \quad (30)$$

For different power fault durations, Equation (30) serves as a limit to define $V(x)$ in Equation (29), that is,

$$V(x) = V_{\text{touch}_{50}}$$

As a typical example of the above, Figure 51 uses Equations (29) and (30) to demonstrate that the distance (x) of the ZOI boundary from the center of the power station ground grid varies as a function of GPR, grid area (πr^2), and power fault duration. Assumptions made to derive these figures are as follows:

- Uniform soil
- Typical value of $1/L$ is approximately 10% of $1/4r$; thus the term $(1 + 4r/L) = 1.1$
- The material under the worker's feet at the ZOI boundary is ρ_s
- Uniform current density in earth

This results in the following equation:

$$\frac{116 + 0.17\rho_s}{GPR\sqrt{t}} = 0.58 \sin^{-1} \frac{r}{x} \quad (31)$$

therefore,

$$x = \frac{r}{\sin \left(\frac{116 + 0.17\rho_s}{0.58 GPR\sqrt{t}} \right)} \quad (\text{m}) \quad (32)$$

CAUTION—Equation (32) is in radians, not degrees.

Note that x is defined as the distance from the center of the ground grid. The ZOI boundary from the edge of the grid is defined as the distance from the edge of the grid to the boundary.

$$\text{distance from edge of grid} = \frac{r}{\sin \left(\frac{116 + 0.17\rho_s}{0.58\sqrt{t}GPR} \right)} - r \quad (\text{m}) \quad (33)$$

Normally, this distance is measured from the edge of the grid, not from the power station fence, as there may be a substantial distance between the station fence and the ground grid.

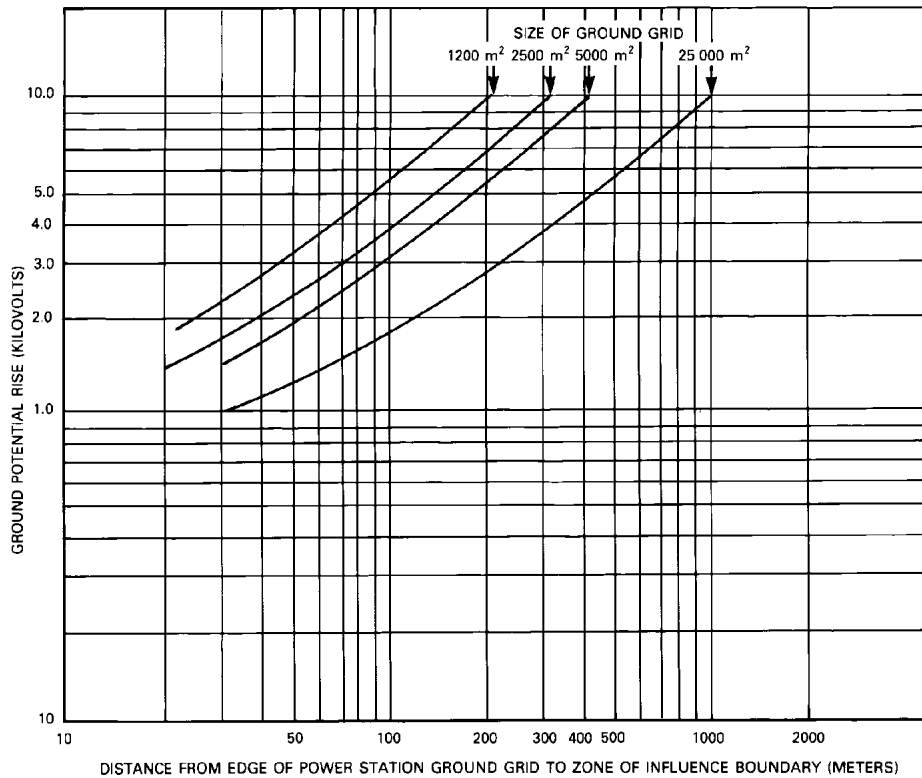

NOTE—All curves assume ρ_s equals $750 \Omega \cdot m$; body weight equals 50 kg.

Figure 51a—Determination of ZOI boundary for power stations (power fault duration: 0.00–0.25 s)

For specific stations where some of the assumptions are known, the boundary should be calculated rather than obtained from Figure 51.

This situation assumes uniform soil.

9.9 Safety considerations

See IEEE Std 80-1986 for further information regarding questions of personal safety (that is, step and touch potential) within the ZOI of a power station GPR.

10. Summary of mitigating and reduction factors applicable to GPR or induced voltages, or both

The design and cost of special protection arrangements that should usually be applied to wire-line telecommunication facilities serving electric power stations to ensure reliable and safe operation are sensitive to the level of the expected electrical environment.

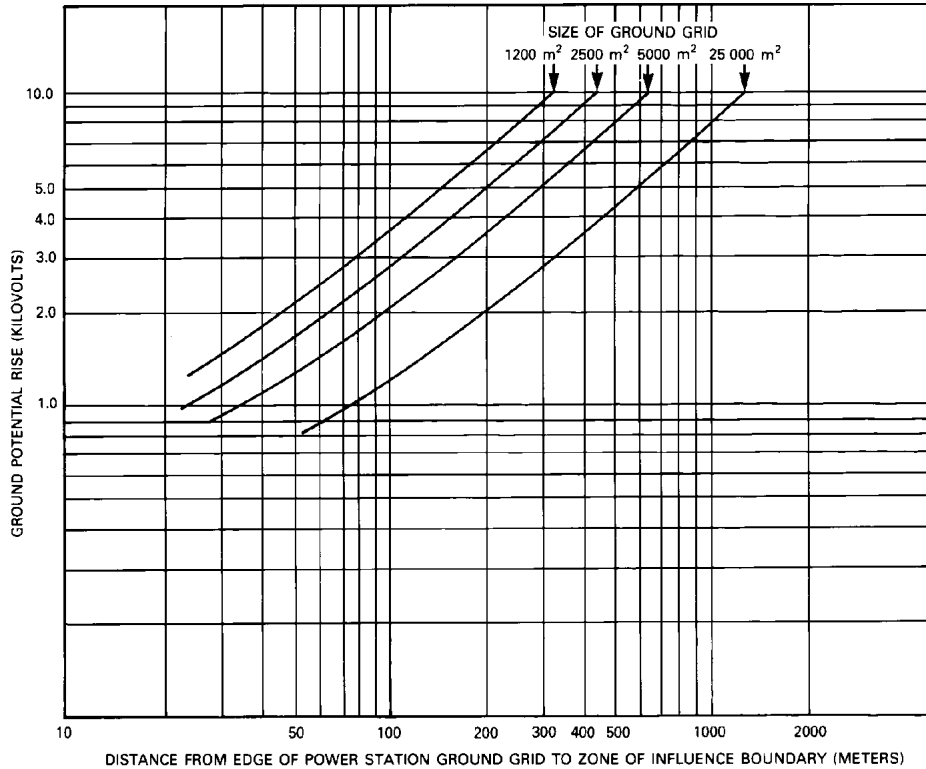

NOTE—All curves assume ρ_s equals $750 \Omega \cdot m$; body weight equals 50 kg.

Figure 51b—Determination of ZOI boundary for power stations (power fault duration: 0.25–0.50 s)

This clause provides the design engineer with information that should be considered in the determination of practical values of GPR or induced voltage, or both, as well as certain mitigating and reduction factors. The effects of longitudinal induction (see Clauses 6 and 7) should also be considered in the overall design.

10.1 Mitigating factors applicable to fault current calculation

Power system faults occurring on predominantly inductive circuits will produce the highest current transients and resulting GPR voltages, when such faults are initiated at a time (that is, a point on the waveform) when the faulted phase approaches 0 V to ground. Insulation failure at a voltage of zero is highly unlikely compared to one taking place at peak voltage, but it will occasionally occur from faults due to lightning or the closing of a breaker into a faulted or grounded line. (See 10.3 for a discussion of dc offset factors.)

The voltage difference between the electric power station ground and a remote ground point, such as a telephone central office or another power station, is the crux of the problem. In some cases, the voltage between these two points is reduced by common metallic connections between them, which are usually not considered in the calculations. These include such incidental paths as steel or iron pipes, buried cables, building footings, metallic rails, etc.

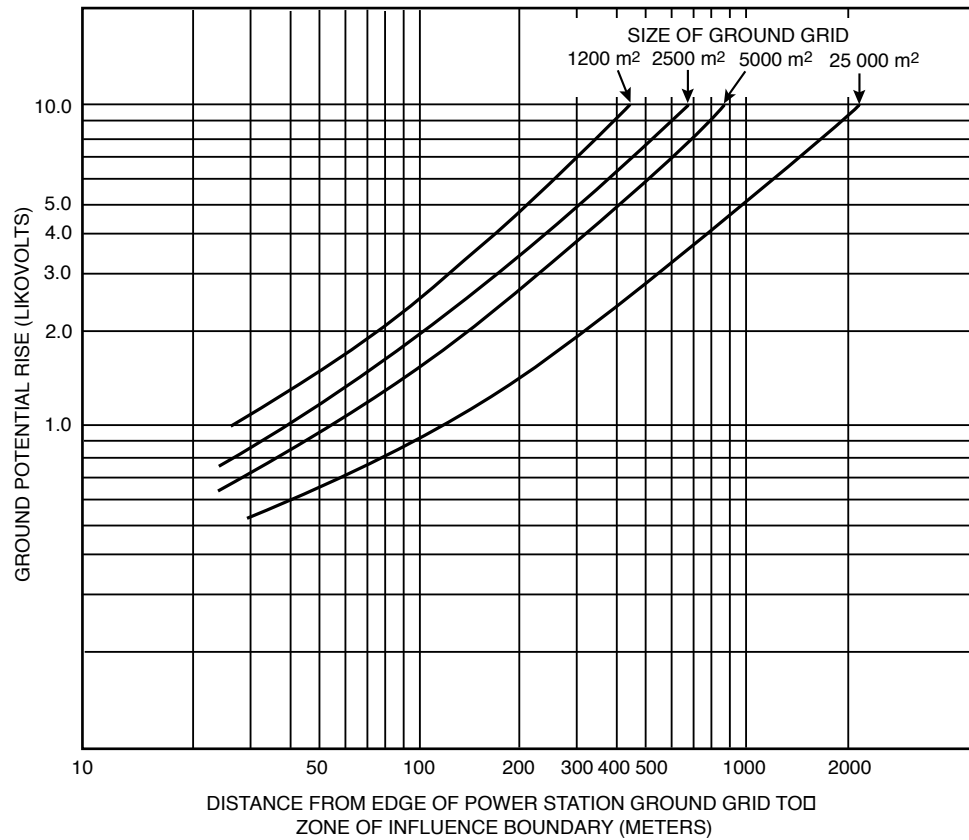

NOTE—All curves assume ρ_s equals $750 \Omega \cdot m$; body weight equals 50 kg.

Figure 51c—Determination of ZOI boundary for power stations (power fault duration: 0.50–1.0 s)

Telecommunication services to generating stations on or adjacent to large bodies of sea water may suffer less interference problems from GPR because of the lower ground grid impedance caused by grounded intake structures, generators, etc., that are not included in the ground resistance calculations.

HV power systems usually have the capability for producing the greatest ground fault current and usually have a higher X/R ratio, which tends to produce a longer duration of dc offset. The higher X/R ratios, applicable to the HV transmission lines, can be considerably reduced by the inclusion of the terminal apparatus in the calculations. The terminal apparatus may mean the transmission or distribution line grounding networks (for both), fault current limiting devices, etc. HV systems, however, have the best system protection in terms of fault detection and fast interruption time. The ground impedance will tend to be low because of the large grid area of these power stations. In distribution systems some distance from the inductive source, the X/R ratio is much lower than in HV systems; consequently, a shorter transient duration is expected but the fault clearing time may be higher.

The X/R ratio to be used for dc offset calculations should be that as seen from the fault location looking back into the power system, far enough to include the reduction of the X/R ratio due to the reducing effects of the terminal apparatus.

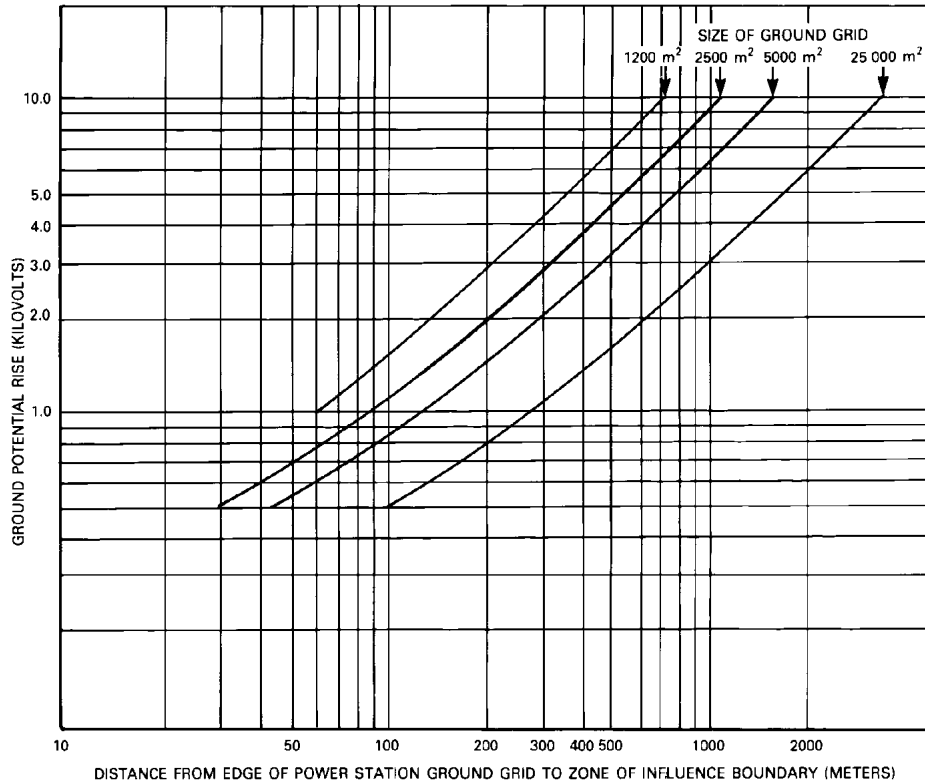

NOTE—All curves assume ρ_s equals $750 \Omega \cdot m$; body weight equals 50 kg.

Figure 51d—Determination of ZOI boundary for power stations (power fault duration: 1.0–3.0 s)

The fault currents and the station ground grid impedance should be determined accurately so that a true value of GPR can be calculated. Where fault currents are higher (for example, 100 kA) and the station ground impedance is low, inaccuracies even in the order of 10% in measuring or calculating station ground impedance will result in critical errors in GPR calculations.

10.2 Mitigating factors applicable to GPR calculations

In order to arrive at a realistic figure for the GPR to be used for telecommunication protection equipment design purposes, calculate the highest symmetrical value of GPR taking into consideration the following points (see Clause 5):

- Use the fault location on the power system that produces the maximum GPR.
- Use only that portion of the total fault current that actually flows through the station ground impedance.
- Use the subtransient reactances of generators for calculating the initial current.

NOTE—If more accuracy is desired, at the proper time after the fault is initiated, the transient reactance should be used with appropriate decrements, and the effects of automatic field voltage regulators should be considered.

- d) Use the X/R ratio at the fault location, evaluated with respect to each fault current source and reduced to the effective value of X/R because of the lower X/R of the terminal equipment.
- e) Assume the fault to be initiated at or close to peak voltage or zero current to yield zero or the minimum dc offset for the particular X/R ratio. The fault is to be considered as not evolving from a single phase-to-ground to a two phase-to-ground fault. Such an evolution is most unlikely to occur at the critical time intervals to produce the worst-case ground fault.

The fault current is affected by fault impedance, arcing faults, the effect of multiple feeds, presence of load current on dc offset, etc., whereas the distribution of fault current is affected by the presence of alternate return paths such as overhead ground wires, cable sheaths, and metallic pipes, etc.

10.3 Reduction or multiplication design factors to be used with the calculated GPR

After having estimated the highest value of symmetrical GPR in accordance with the factors in 5.1, a design value of GPR for use in the preparation of wire-line telecommunication protection specifications may then be ascertained by applying additional factors that would either increase or decrease the calculated GPR.

Appropriate multiplication factors (see 5.1.5) may be applied to adjust the maximum calculated symmetrical GPR to arrive at a design value for wire-line telecommunication protection that reflects the probability of the occurrence of the type of fault being considered. Ideally, the acceptable design values of GPR should consider power system fault statistics, the probability of the fault occurring at a location to give a maximum GPR, and the coincident probability of the fault occurring at a point on the waveform to yield the maximum dc offset.

These statistics should be used for designing to an acceptable failure rate consistent with the economics involved. Unfortunately, little statistical data is presently available. The design value can be based on the value of the maximum calculated symmetrical GPR with the application of certain multiplication factors. These factors should reflect the importance of the power station, economics, operating experience, uncertainties, and assumptions, as well as the methods used for the GPR calculations. Typical multiplication factors that may be applied to the calculated maximum GPR are as follows.

- a) Based on the judgment of the particular or individual power utility as to what amount of dc offset they wish to protect against, a multiplying factor anywhere from 1.0 to 1.3, or even higher in unusual cases, could be applied to determine the maximum peak GPR design voltage. (See 5.1.5, 9.4, 10.1, and 10.3).
- b) Based on a worst-case single phase-to-ground fault evolving into a two phase-to-ground fault, a multiplication factor of 1.25–1.5 times the value derived in 10.2 could be applied. This situation would refer only to an unusually important power station where wire-line telecommunication facilities are used for protective relaying and where both dependability and security are absolutely essential. The cost of the wire-line telecommunication protection is of secondary importance. However, the probability of encountering this type of situation is very remote; thus, this category is rarely used [see item e) of 10.2].

10.4 Chemical grounds

The effective impedance of a grounding grid can be reduced by the addition of certain chemicals to the bed of the grid or ground rods. Caution should be exercised with regard to adverse environmental effects and to reduced long-term effectiveness of chemical treatments.

11. Communication channel time requirements

To provide both reliability and economy of service to the customer, electric power systems serve large load centers by multiple transmission lines, generators, and transformers. These complex systems have special operating conditions that require high-speed clearing of short circuits and other abnormalities. This is accomplished by protective relaying systems that should distinguish between normal load currents and fault currents, which then isolate the faulty section before equipment is damaged; otherwise, the entire system is disrupted.

Protective relaying systems often use communication systems to assist in the fast determination of the location of the fault or to send a signal to a distant location in order to open a breaker so as to clear a fault.

Communication channels used for protective relaying need to remain operable from the initiation of a fault on through the time the fault is cleared. Although the majority of faults on a modern HV system can be cleared in 40–120 ms, others can require over 300 ms, and local breaker failure relays can add an additional 200 ms to these times. Other operations, such as time-overcurrent relays, often used for LV feeder protection and bus and transformer backup, can indicate that a 2–3 s timing interval for fault clearing should sometimes be considered. Also, automatic reclosing into a permanent fault may substantially increase the total time that a fault persists on the system.

NOTE—The protective relay systems and operating times given are for typical systems. The relay systems and relay timing should be obtained for each system under study, just as fault currents should be obtained for each system under study.

11.1 Power system fault protection

There are many different types of protective relaying systems, depending upon the clearing-time requirements, stability requirements, voltage of the system, function of the system, age of the system, and the corporate philosophy of the owning utility. Precise requirements for each application of communication channel protection equipment at a substation should be obtained from the power utility engineer responsible for the protective relaying system. The following information will serve as a guide.

- a) Protective relays monitoring electric power systems receive their input signals from current and potential transformers, capacitive voltage transformers, pressure contactors, and thermal sensors.
- b) Protective relays detect faults by computing current and voltage magnitudes, impedance, direction of power flow, phase angles, time, frequency, and various combinations of these parameters.
- c) Faults are interrupted by oil, air, and gas circuit breakers, as well as air and vacuum switches and fuses.

Circuit breakers open very fast after initiation of a trip signal from a protective relay. Some EHV breakers operate in less than 2 cycles (33 ms). Modern breakers in the 115–230 kV class generally open in 2–3 cycles (33–50 ms), while most LV distribution breakers have tripping times in the 3–5 cycle range (50–83 ms).

Fault interruption for power fuses varies widely, from 1 cycle to several minutes, since clearing time is almost solely dependent on the ampere rating of the fuse and on the fault current magnitudes.

Air-break switches are not normally designed to interrupt faults. They have opening times of 0.5–1.5 s.

Vacuum switches typically clear faults in 3–4 cycles.

11.2 Protective relay types

Differential relays are designed to detect the difference between power in and power out and are used to protect transformers, generators, reactors, and substation buses. An imbalance exceeding a designed threshold is defined as a fault condition, and tripping will be initiated in 17–50 ms.

Fault pressure relays are installed on power transformers and large shunt reactors. They are designed to sense a sudden buildup of pressure in the oil or in the space above the oil and normally initiate tripping in 17–50 ms.

Transformers, reactors, and large motors may also be equipped with thermal relays that operate on high temperature. These devices are relatively slow, with operating times as long as several seconds or even minutes.

Frequency relays sense an over- or underfrequency condition or system instability, or both. They are usually installed to provide catastrophic load relief and to preserve the integrity of the interconnected system. Frequency relays are not affected by fault current but may be inhibited by low voltage. Their operation will not contribute to GPR.

Independent timing relays may sometimes be employed to supervise the operation of other relays. They may be set to operate from milliseconds to seconds and are frequently used to provide coordination with other protective devices.

Instantaneous-overcurrent relays operate on a preset value of current and trip with no intentional delay. They normally initiate tripping in 8–16 ms. These relays are also used extensively for supervising other relays.

The operating time of time-overcurrent relays is dependent on current (tap) setting and the time delay (time dial) setting. It varies inversely with the magnitude of the fault current and ranges from 32 ms to several seconds. Time-overcurrent relays are used extensively on radial feeders and for certain backup functions. Most ground relays are time-overcurrent relays. On HV and EHV transmission lines, the time-overcurrent element is supervised by a directional unit.

Impedance relays sense a ratio of voltage to current and respond if the measured impedance is less than the preset value, indicating a fault on-the-line being protected. Impedance relays are directional, are generally independent of generation level or system configuration, and provide good discrimination between faults and loads. They are widely used on network transmission lines and can initiate tripping in 8–40 ms. At least two impedance relays and a time delay relay are required at each line terminal. The first relay is set for instantaneous tripping for 85–90% of the protected line (see Figure 52, zone 1), and the second relay (see Figure 52, zone 2) is set for 115–130% of the line impedance. Since this second relay may reach well into the next line section, its operation is delayed to allow time for relays on the adjacent line(s) to clear faults on that line. If the associated timing relay is set for 15–30 cycles to provide this coordination interval, fault clearing in the last 10–15% of the protected line will be delayed by this amount. Note that impedance relays may be used for both phase and ground fault protection. In some cases, the various relay functions are included in one package.

11.3 Communication systems factors

Communication plays a vital role in the high-speed clearing of a fault. Circuit breakers at all terminals of a line should be opened simultaneously to ensure that the line is dead and the fault current is extinguished.

Power systems communications have unique reliability and security requirements. The systems have evolved over the years, and many different communication modes and signaling modes are in use today.

- a) *Amplitude modulated signaling systems* are used primarily with a power line carrier.
- b) *Simple frequency shift systems* can be used with a power line carrier, audio tones on wire line, microwave, wide-band power line carrier, and with fiber optics.
- c) *Digitally encoded frequency shift systems* are more advanced signaling systems and can be used on any of the communication systems mentioned above except an amplitude-modulated power line carrier.
- d) *Digitally encoded all-digital systems* are advanced relay communication systems that can be used on any digital communication channel.

An audio-tone permissive overreaching system is used in the following example to explain how relays and communication systems are used in a coordinated way for high-speed clearing of faults. All systems (except an amplitude-modulated power line carrier) operate in basically the same way even if they use different communication media and encoding techniques.

11.4 Relaying schemes

Special high-speed relaying systems with communication channels are installed to protect the line. One such system is the permissive overreaching system, which is illustrated in Figure 53. This system requires either a microwave, fiber optic, broad-band power line carrier, or wire-line channel as a communication medium. This is an audio tone, frequency shift scheme in which the transmitter at each terminal of the protected line sends a continuous guard signal to the remote receiver to block tripping. When a fault occurs within the reach of the zone 2 relay, a trip signal is sent to the local breaker and the local transmitter frequency is shifted to the trip frequency. Tripping occurs if the local receiver receives a trip signal from the remote terminal. Note that the zone 2 timer is bypassed for this operation. Examination of Figure 53 will show that fault 1 and fault 2 will be detected by both zone 2 relays, so that both transmitters will be shifted to the trip frequency and the fault will be cleared with high speed, the only additional delay being that of the communication channel and the audio tone equipment, generally about 4–16 ms. If the fault is external to the protected line (see Figure 53, fault 3), even though the relays at breaker D may detect the fault and key its transmitter, the relays at breaker C, being directional, will not detect the fault, will not trip breaker C, and will continue to transmit a guard signal to block tripping of breaker D.

A phase comparison relaying system analyzes the location of a fault by comparing the phase relationship of fault currents at each end of a protected line. Power line carrier or audio tone equipment is commonly used as a communication channel. If the fault currents on-the-line are in phase, the fault is considered to be external to the protected line and a tripping will be blocked. If the fault currents on-the-line are out of phase, the fault is internal and tripping normally will take place. In general, the fault is sensed and tripping is initiated in 8–20 ms. A channel failure, reduced signal level, or noise at the time of fault may cause improper operation, either disallowing a necessary trip or causing an incorrect operation, depending on the fault location. Please note that relay engineers usually speak of the current phase relationship out of the current transformers (CTs) rather than on-the-line. It can be seen that in the way current transformers are connected, the currents out of the CTs will be in phase for a fault on the protected line and out of the phase for a fault on-the-line beyond.

Pilot wire relaying is a differential protection scheme designed to protect transmission lines by comparing the polarity of circulating current in a metallic communication circuit to determine if the fault is internal or external to the protected line. An open or short circuit in the communication pair can prevent a correct operation. However, independent monitoring systems are available that can signal the system operator upon the occurrence of a communication cable fault. Some pilot wire systems are now using fiber-optic channels

A transferred-tripping scheme is designed to transfer a trip signal from a local protective relaying terminal to a remote terminal for the purpose of tripping the remote breaker. Almost any type of conventional communication channel may be employed. Transferred tripping is used to protect lines and transformers and for

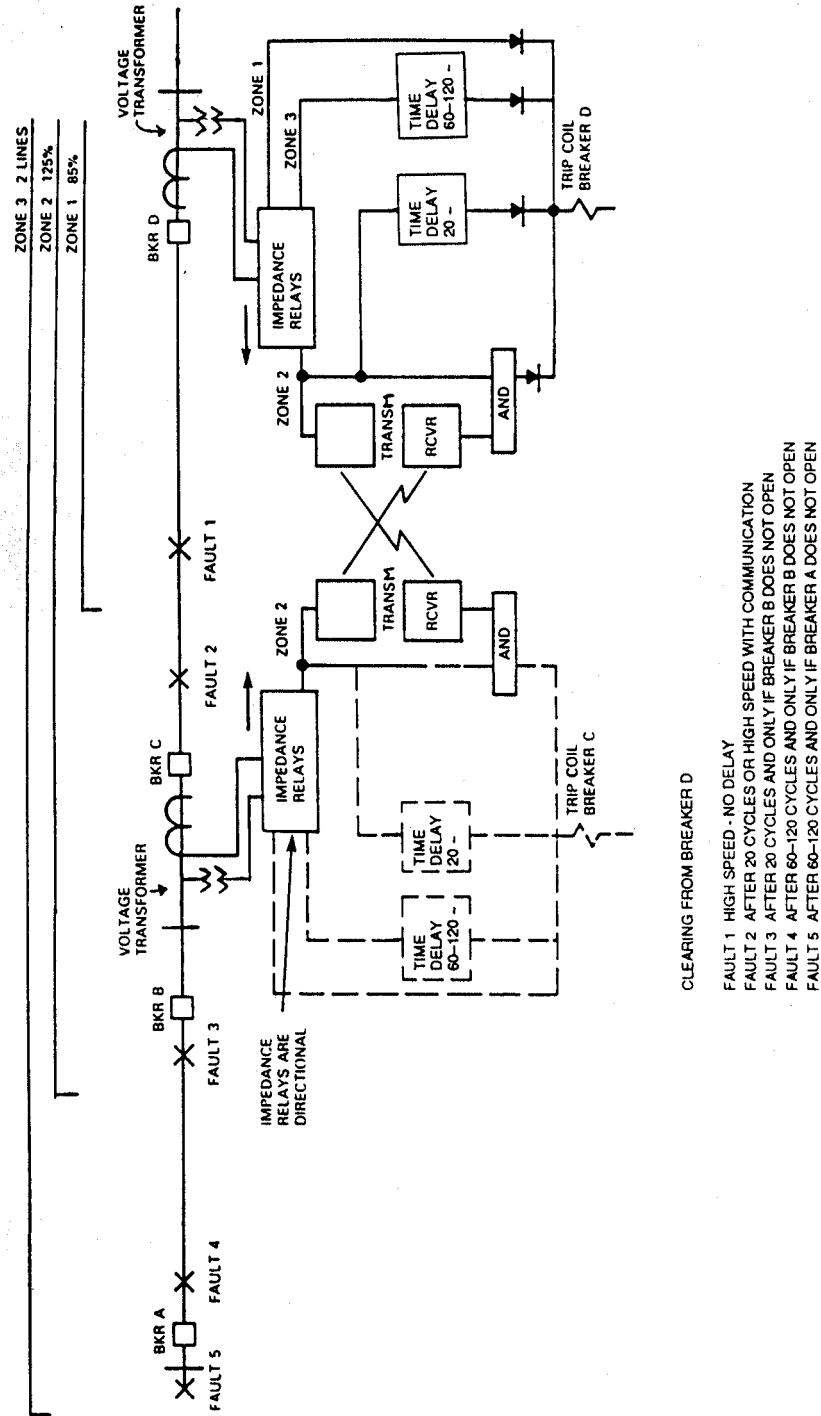

Figure 53—Typical impedance protection system with communications

breaker failure protection. Direct unsupervised tripping, upon receipt of the trip signal by the receiver, places severe security requirements on the communication channel and related equipment. For security, usually two signals are sent in parallel and received in series. Transmitter-receiver time is 4–12 ms and channel time is 1–10 ms, with total tripping initiation times of generally less than 16 ms (see Figure 54).

Backup systems should be provided to protect the power system from the failure of a relay to detect a fault or a breaker to open.

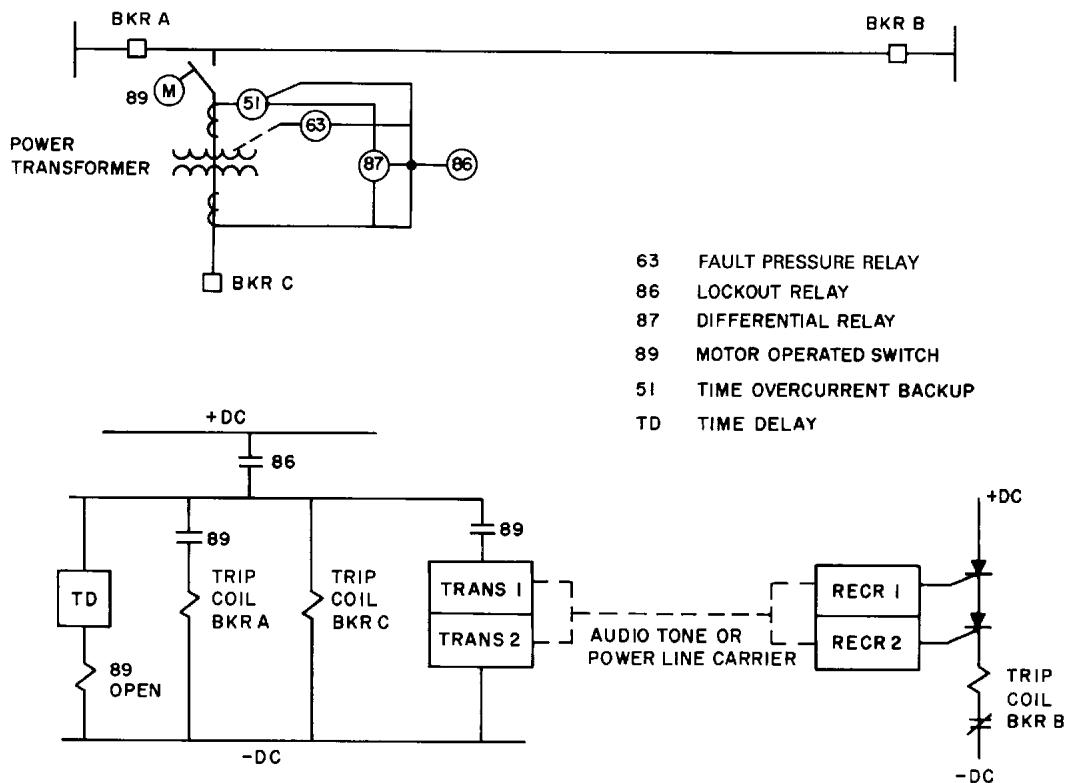

Figure 54—Simplified transfer trip system

Remote backup can be accomplished by using a zone 3 impedance relay set (see Figure 52) to protect its own line and all of the next line. Proper coordination with the adjacent line is obtained by using a time delay to give the adjacent line breakers a chance to clear before the backup relay operates. With this system, all faults not cleared in proper time will then be cleared in 1.5–3 s by the backup relay. This has the disadvantage of being slow, and at times it may be difficult for the zone 3 impedance relay to distinguish between load and far-end faults on the adjacent line. Zone 3 relays are seldom used in modern systems.

Local backup for line faults is accomplished by using redundant relaying systems plus a breaker failure scheme. The OR logic gates of all line relays are combined with an AND logic gate of an overcurrent fault detector for each circuit breaker and connected to a timer to provide coordination. This scheme will detect the failure of a circuit breaker to trip within a preset time—usually 6–10 cycles on EHV systems and 10–15 cycles on others—and open all other sources of fault current to the faulted element. Certain bus arrangements, such as a ring bus, require a transfer trip system to open a remote breaker if high-speed fault clearing is required. This is particularly true on EHV systems.

Most systems use automatic reclosing after a fault. These additional clearing times should be considered. Table 12 can be used as a guide. Generally, the higher the system voltage, the faster the fault is cleared and the faster the breakers reclose, although they may reclose fewer times.

Some EHV systems utilize single-phase tripping and reclosing. This means the remaining phases remain energized and continue to carry load during the normal reclose dead time. The imbalanced current that flows for this brief interval (about 0.3–0.4 s) will generally not cause problems for communication circuits.

Fast, secure, and reliable communications are necessary on permissive overreach, phase comparison, and transfer tripping. A channel failure, increase, or decrease in level, test tone, or noise at the time of fault may cause improper operation, either by causing the communication receiver to squelch and thereby disallowing a necessary trip (for upward of 2 s on some systems) or by causing an unwanted trip, depending on the data transmission logic. Since no fault detector is used with a transfer trip system, an unwanted trip could occur any time any of the previously mentioned channel conditions exist, particularly on a single-channel system.

Table 12—Typical trip and reclosure sequence

| Voltage (kV) | Clearing time | Dead time | Clearing time | Dead time | Clearing time | Dead time | Clearing time | Dead time |
|--------------|---------------|-----------|---------------|-----------|---------------|-----------|---------------|-----------|
| 500 | 2–4 c | 20 c | 2–4 c | Stop | | | | |
| 345 | 2–4 c | 20 c | 2–4 c | 20 c | 2–4 c | Stop | | |
| 230 | 3–5 c | 20 c | 3–5 c | 15 s | 3–5 c | Stop | | |
| 115 | 3–8 c | 25 c | 3–8 | 15 s | 3–8 | Stop | | |
| 69 | 4–40 c | 2–4 s | 4–40 c | 15 s | 4–40 c | Stop | | |
| 34 | 4–60 c | 2–4 s | 4–60 c | 15 s | 4–60 c | 45 s | 4–60 c | Stop |
| 4/12/25 | 5–120 c | 3 s | 5–120 c | 15 s | 5–120 c | 45 s | 5–120 c | Stop |

NOTE 1—1 c (cycle) is equal to 16.67 ms.

NOTE 2—Tripping by zone 2 relay can add 300–400 ms to the 115–500 kV times.

NOTE 3—Tripping by time-overcurrent ground relay could extend times to 1.5 s on voltages below 230 kV.

NOTE 4—Dead time is followed by closing of the breaker.

12. Administrative guidelines for coordination between communication and power utilities

Frequently the telephone or telecommunication protection engineer will have obtained GPR estimates that seem incredibly high, or that prove to be so in practice. For example, an initial quoted GPR figure can be revised downward from the original figure after a few appropriate questions have been asked. As well, actual measured ground resistances (impedance) have sometimes been found to be a fraction of the original calculated or stated values.

12.1 Acquiring data on substation electrical environments

The most accurate data on substation environments can be obtained by directing the proper questions to the correct engineer. The following are notes and questions that the telephone protection or telecommunication protection engineer should ask the power utility engineer in order to obtain a realistic value of the GPR.

- a) Make certain that the appropriate engineer in the power utility has been contacted. Such a person will typically be called a “Stations” or “Systems Planning Engineer” or “Systems Protection Engineer” with responsibilities of determining fault current levels or the amount of current injected into various parts of the system when faults to ground occur. For ground grid impedance values, this engineer might either be a “Planning,” a “Substations,” or a “Transmission Line” engineer. These may, however, be personnel in the power utility—for example, a Power Systems Communications Department that is also responsible for inductive coordination studies and is familiar with all aspects of these studies. Determine if the person contacted has the responsibility for station specifications of the power location in question. If not, seek out the individual having such responsibility.
- b) Obtain the station ground impedance value to remote earth, the maximum single-phase fault current, and, hence, the GPR. If the GPR given is the product of the first two numbers, it is probably higher than actual, as not all the fault current returns through the ground grid. Ask what part of the total fault current actually flows from ground to the grid. This can be a complicated question requiring the use of a computer for an answer.

- c) Inquire if the ground grid impedance (Z_{SGT}) was calculated or measured and if the overhead ground wires and distribution neutrals were connected when the impedance was determined. A calculated value may be based upon a worst-case design estimate and may be inaccurate. Unfortunately, a design engineer may be depending on inaccurate soil resistivity figures. Be insistent, particularly on an estimate with the distribution neutral and overhead ground wires connected, as this can reduce Z_{SGT} by as much as an order of magnitude.

There is no substitute for a real measurement; therefore, if measured impedance values can be obtained, then do so. However, beware of stated or calculated values below 1 Ω . For example, most small test sets should not be trusted below 1 Ω . IEEE Std 81-1983 and IEEE Std 81.2-1991 illustrate accurate methods of testing the station ground. Questions should be asked concerning the methods, test procedures, and equipment used to measure the ground grid impedance when determining credibility of the data provided.

- d) Establish the validity of fault current levels. Fault current estimates should be based on an L-G fault. If the estimate is for an L-G developing into a 2L-G phase fault, a worst-case scenario is assumed. Because of the rarity of a 2L-G fault, it should be discarded in favor of the L-G fault. The L-G figure may include a large dc offset value. If so, a reduction in the dc offset value may be appropriate. The value of the GPR should be given in the rms symmetrical value. Peak or dc offset factors can be applied later to the GPR calculation by agreement. Next, ask the engineer for which fault location the GPR was calculated.

12.2 Studies of substation electrical environment

Planning studies for the substation electrical environment are usually for periods of 5 to 20 or more years. The fault studies are based on ultimate figures, but the station may never reach this capacity or may reach this ultimate value many years hence. Decide for what length of time the protection design will be valid and request a fault current prediction for this period. Such a request for information should be put in writing. The telecommunication protection engineer should now be able to determine if the GPR information received is realistic.

The electric power utility creates the GPR and induction environment and is therefore responsible for defining it. The telecommunication utility protection engineer should complete the protection design(s) based on reliable data supplied by the power utility. The motivations for an accurate and reasonable assessment of the GPR or induced voltage or both, are economic, the increased reliability of telecommunication services, and the increased personnel and plant safety. In order to arrive at a realistic assessment of the assumed magnitude of interfering voltages, a very high degree of mutual understanding and cooperation is necessary.

Large power utilities have the engineering capability to provide either by calculation or measurement, or both, accurate values for the inducing current and the net earth return portion of the fault current. Also, most large utilities can provide accurate values for ground grid impedance and hence the GPR. The degree of accuracy required and the economics related to determining the appropriate value of GPR, particularly for very large stations, are subjects for negotiation. Many small power utilities, private designers, or contractors do not have this level of expertise and may elect to use outside special consultants.

13. Bibliography

[B1] Allan, R. N., Billinton, R., and Lee, S. H., *Bibliography on the Application of Probability Methods Power System Reliability Evaluation*, IEEE/PES 1983 Winter Meeting.

[B2] Almeida, M. A., Cherchiglia, L. C. L., and Assumpcao, H. G., *Substation Phase-to-Ground Short-Circuit Current Distribution*. CIGRE 1984 36-03.

- [B3] Anders, G. J., Dandeno, P. L., and Neudorf, E. E., *Computation of Frequency of Severe Power System Faults*, IEEE/PES 1984 Winter Meeting.
- [B4] AT&T, *Fundamentals of Inductive Interference Calculations*. 873-600-101, Iss. 1, Feb. 1979.
- [B5] AT&T, *Low Frequency Coupling Factors For Ground-Return Circuits: General Considerations and Methods of Calculation*. 873-800-177, Iss. 1, Nov. 1974.
- [B6] Blattner, C. J., "Analysis of Soil Resistivity Test Methods in Two-Layer Soil." *IEEE Transactions on Power Apparatus and Systems*, vol. PAS-104, no. 12, pp. 3603–3608, Dec. 1985.
- [B7] Borucki, R. and Szymanski, G., "Earth-Fault Current Distribution and Potentials in Overhead A.C. Transmission Lines." *Energoprojekt Poznan*, Poland, 1982.
- [B8] Burke, J. J. and Lawrence, D. J., "Characteristics of Fault Currents on Distribution Systems." *IEEE Transactions on Power Apparatus and Systems*, vol. PAS-103, no. 1, pp. 1–6, Jan. 1984.
- [B9] Carson, J. R., "Wave Propagation in Overhead Wires with Ground Return," *Bell Systems Technical Journal*, pp. 539–554, Oct. 1926.
- [B10] CCITT Directives, Chapter XII, "The Protection of Telecommunications Lines Against Harmful Effects of Electricity Lines." 1963, pp. 129–137.
- [B11] CCITT Study Group V, *The Electromagnetic Field Due to a Line Source Above a Uniform Earth of Finite Conductivity*, COM V, No. 30-E, Aug. 1982.
- [B12] CIGRE Study Committee 36 on Interference, Working Group 02, Volume 108, Paris, 1986. CSA C22.3 No. 3-1954 (Reaff 1970), Inductive Coordination—Definitions.
- [B13] CSA C22.3 No. 3-1954 (Reaff 1970), Inductive Coordination—Definitions, Principles and Practices.
- [B14] Corbett, L. J., *Inductive Coordination of Electric Power and Communication Circuits*. J. H. Neblett Pressroom, Ltd., 1936.
- [B15] Dabkowski, J., *The Calculation of Magnetic Coupling from Overhead Transmission Lines*, IEEE/PES 1981 Winter Meeting.
- [B16] Dawalibi, F. and Barbeito, N., "Measurements and Computations of the Performance of Grounding Systems Buried in Multilayer Soils." *IEEE Transactions on Power Delivery*, vol. 6, no. 4, pp. 1483–1490, Oct. 1991.
- [B17] Dawalibi, F. and Blattner, C. J., "Earth Resistivity Measurement Interpretations Techniques." *IEEE Transactions on Power Apparatus and Systems*, vol. PAS-103, pp. 374–382, Feb. 1984.
- [B18] Dawalibi, F. and Mukhedkar, D., "Influence of Ground Rods on Grounding Grids." *IEEE Transactions on Power Apparatus and Systems*, vol. PAS-98, pp. 2089–2098, Nov./Dec. 1979.
- [B19] Dawalibi, F. and Mukhedkar, D., "Optimum Design of Substation Grounding in a Two-Layer Earth Structure." *IEEE Transactions on Power Apparatus and Systems*, vol. PAS-94, no. 2, pp. 252–272, Mar./Apr. 1975.
- [B20] Dawalibi, F. and Mukhedkar, D., "Parametric Analysis of Grounding Grids." *IEEE Transactions on Power Apparatus and Systems*, vol. PAS-98, no. 5, pp. 1659–1668, Sept./Oct. 1979.

- [B21] Deri, A. et al., "The Complex Return Plane — A Simplified Model for Homogeneous and Multilayer Earth Return." *IEEE Transactions on Power Apparatus and Systems*, vol. PAS-100, no. 8, Aug. 1981.
- [B22] *EHV Transmission Line Reference Book*, Edison Electric Institute, 1968.
- [B23] *Electric Utility Engineering Reference Book, vol. 3, Distribution Systems*. Westinghouse Electric Corporation, 1965.
- [B24] *Electrical Transmission and Distribution Reference Book*. Central Station Engineers of the Westinghouse Electric Corporation, Westinghouse Electric Corporation, chapter 3, p. 41, 1964.
- [B25] Elek, G. R. and Pokas, B.E., *A Case of Inductive Coordination*. Paper F 76-471-3, IEEE Summer Power Meeting, Portland, OR, July 1976.
- [B26] El-Kady, M. A. and Vainberg, M. Y., "Risk Assessment of Grounding Hazards Due to Step and Touch Potentials Near Transmission Line Structures." *IEEE Transactions on Power Apparatus and Systems*, vol. PAS-102, pp. 3080–3087, Sept. 1983.
- [B27] *Engineering Reports*, vol. 1, 1930; vol. 2, 1932; vol. 3, 1937; vol. 4, 1937; and vol. 5, 1943. Joint Subcommittee on Development and Research of the Edison Electric Institute and the Bell Telephone System.
- [B28] Feist, K. H., *The Zone of Influence of Ground Potential Rise*. CIGRE Paper, SC 36/WG, 02, Aug. 2, 1976.
- [B29] Frazier, M. J. and Dabkowski, J., *Magnetic Coupled Longitudinal Electric Field Measurements on Two Transmission Lines*, IEEE/PES Summer Meeting.
- [B30] *Fundamentals of Inductive Coordination*. Commonwealth Associates, Inc., 1991.
- [B31] Geer, E. W., Jr. and McLellan, D. W., "Protecting Telephone Lines from Induced Voltages." *Telephony*, Aug. 26, 1974.
- [B32] Giordano, R., Mark, D. A., Rostkowski, C. J., Schall, B. and Sommer, K. O., "Computer Assisted Design of Substation Grounding." *IEEE Transactions on Power Apparatus and Systems*, vol. PAS-104, no. 7, pp. 1864–1866, July 1985.
- [B33] *Green Book, vol. 9: Protection*. International Telegraph and Telephone Consultative Committee (CCITT), V Plenary Assembly, Geneva, Dec. 4–15, 1972. International Telecommunication Union, 1972.
- [B34] Han, Z. X., *Generalized Method of Analysis of Simultaneous Faults in Electrical Power Systems*, IEEE/PES 1982 Winter Power Meeting.
- [B35] *Handbook on Earthing of Telecommunication Installations*. International Telegraph and Telephone Consultative Committee (CCITT), 1976.
- [B36] Heppe, R. J., "Computation of Potential at Surface Above an Energized or Other Electrode, Allowing for Non-Uniform Current Distribution." *IEEE Transactions on Power Apparatus and Systems*, vol. PAS-98, no. 6, pp. 1978–1989, Nov./Dec. 1979. Corrections, vol. PAS-99, no. 2, p. 535, Mar./Apr. 1980.
- [B37] Heppe, R. J., "Step Potentials and Body Currents Near Grounds in Two-Layer Earth." *IEEE Transactions on Power Apparatus and Systems*, vol. PAS-98, no. 1, pp. 45–59, Jan./Feb. 1979.
- [B38] Hunt, Frank B., *A Semi-Cycle of Ground Potential Rise*. IEEE ICC '71, 1971.

- [B39] Hurley, W. G. and Croall, S. J., *Electromagnetic Voltage Induction and Mitigation on Passive Conductors from Overhead Transmission Lines*, IEEE/PES 1983 Winter Meeting.
- [B40] Joy, E. B., Meliopoulos, A. P., and Webb, R. P., *Analysis of Substation Grounding Systems*, Final Report on EPRI Research Project 1494-2, July 1982.
- [B41] Larsen, S. L. and Nordell, D. E., "The Measurement of Substation Ground Resistance and Its Use in Determining Protection for Metallic Communication Circuits." *IEEE Transactions on PES*, vol. 94, Sept./Oct. 1975.
- [B42] Lazzara, J. and Barbeito, N. "Simplified Two-Layer Model Substation Ground Grid Design Methodology." *IEEE Transactions on Power Delivery*, vol. 5, no. 4, pp. 1741–1748, Nov. 1990.
- [B43] Levey, L., "Calculation of Ground Return Fault Currents Using an Equivalent Circuit and a Simplified Ladder Network." *IEEE Transactions on Power Apparatus and Systems*, vol. PAS-101, no. 8, p. 2491, Aug. 1982.
- [B44] Levey, L., "Computation of Fault Currents and Voltages Along a Multigrounded Neutral Power Line Having Multiple Phase Conductors." IEEE Power Engineering Society, 91 WM104-0 PWRD.
- [B45] Mason, C. R., *The Art and Science of Protective Relaying*. New York: John Wiley & Sons, 1956.
- [B46] McLellan, D. W. and Valentino, A. R., "ELF Earth Return Current Coupling." *IEEE Transactions on EMC*, vol. EMC-15, no. 4, Nov. 1973.
- [B47] Meliopoulos, A. P. and Palalexopoulos, A. D., "Interpretation of Soil Resistivity Measurements: Experience With the Program SMMIP." *IEEE Transactions on Power Delivery*, vol. PWRD-1, no. 4, pp. 142–152, Oct. 1986.
- [B48] Meliopoulos, A. P., Webb, R. P., and Joy, E. B., "Analysis of Grounding Systems." *IEEE Transactions on Power Apparatus and Systems*, vol. PAS-100, no. 3, pp. 1039–1048, Mar. 1981.
- [B49] Meliopoulos, A. P., Webb, R. P., Joy, E. B., and Patel, S., "Computation of Maximum Earth Current in Substation Switchyards." *IEEE Transactions on Power Apparatus and Systems*, vol. PAS-102, no. 9, pp. 3131–3139.
- [B50] Morched, A. S., Tench, G. A., and Kundur, P., *Accurate Calculations of Asymmetrical Fault Currents in Complex Power Systems*, IEEE/PES 1981 Winter Meeting.
- [B51] Nahman, J. and Salamon, D., "Analytical Expressions for the Resistance of Rodbeds and of Combined Grounding Systems in Non-Uniform Soil." *IEEE Transactions on Power Delivery*, vol. 1, no. 3, pp. 90–96, July 1986.
- [B52] Nahman, J. and Salamon, D., "Effects of the Metal Sheathed Cables Upon the Performances of the Distribution Substations Grounding Systems." *IEEE Transactions on Power Delivery*, vol. 7, no. 3, pp. 1179–1187, July 1992.
- [B53] Nichols, N. and Shipp, D. D., *Designing to Avoid Hazardous Transferred Earth Potentials*. IPSD 81-52, 1981 Industry Applications Society Annual Meeting, Philadelphia.
- [B54] Olsen, R. G. and Jaffa, K. C., "Electromagnetic Coupling from Power Lines and Magnetic Safety Analysis." *IEEE Transactions on Power Apparatus and Systems*, vol. PAS-103, no. 12, pp. 3595–3607, Dec. 1984.

[B55] Olsen, R. G. and Pankaskie, T. A., "On the Exact, Carson and Image Theories for Wires at of Above the Earth's Interface." *IEEE Transactions on Power Apparatus and Systems*, vol. PAS-102, pp. 769–778, Apr. 1983.

[B56] Parker, J. C., Jr., "Hand Held Calculator Program for Evaluating External Mutual Impedance," Bell Laboratories Technical Memorandum, Feb. 1980.

[B57] Pesonen, A. J., "Effects of Shield Wires on the Potential Rise of H. V. Stations." *Electricity in Finland*, 53 (1980).

[B58] Pillai, P. R. and Dick, E. P., "A Review on Testing and Evaluating Substation Grounding Systems." *IEEE Transactions on Power Delivery*, vol. 7, no. 1, pp. 53-61, Jan. 1992.

[B59] Roy, L. and Rao, N. D., *Exact Calculation of Simultaneous Faults Involving Open Conductors and Line-to-Ground Short Circuits on Inherently Unbalanced Power Systems*, IEEE/PES 1982 Winter Meeting.

[B60] Semlyen, A. and Shirmohammadi, D., *Calculation of Induction and Magnetic Field Effects of Three Phase Overhead Lines above Homogeneous Earth*, IEEE/PES 1982 Winter Meeting.

[B61] Sorbal, S. T., Fleury, V. G. P., Villalba, J. R., and Mukhedkar, D., "Decoupled Method for Studying Large Interconnected Grounding Systems Using Microcomputers, Part I—Fundamentals." Paper 86 SM 455-0, presented at IEEE/PES Summer Power Meeting, Mexico City, Mexico, July 20–25, 1986.

[B62] Sunde, E. D., *Earth Conduction Effects in Transmission Systems*. New York: Dover Publications, Inc., 1968.

[B63] Szabados, B., *The Neutral Current Shift on Distribution Feeders: Theory and Field Tests*. IEEE NTC Conference Record, 1976.

[B64] Takahashi, T. and Kawase, T., "Analysis of Apparent Earth Resistivity in a Multi-Layer Earth Structure." *IEEE Transactions on Power Delivery*, vol. 5, no. 2, pp. 604-612, Apr. 1990.

[B65] Tibensky, M. S. and Perfecky, L. J., *Methods for RMS Symmetrical Station Ground Potential Rise Calculations for Protection of Telecommunications Circuits Entering Power Stations*. IEEE Paper 81 SM 392-0, Dec. 1981.

[B66] *Transmission Line Reference Book, 345 kV and Above*. Electric Power Research Institute, 1975.

[B67] Valazquez, R., Reynolds, P. H., and Mukhedkar, D., "Earth-Return Mutual Coupling Effects in Ground Resistance Measurements of Extended Grids." *IEEE Transactions on Power Apparatus and Systems*, vol. PAS-102, no. 6, pp. 1850–1856, June 1983.

[B68] Wagner, C. F., "Decrement of Short-Circuit Currents." *Electric Journal*, Mar. 1933.

[B69] Wait, J. R., *Electromagnetic Waves in Stratified Media*. New York: MacMillan Co., 1962.⁴

[B70] Weedy, B. M., *Electric Power Systems*, 2nd ed. New York: John Wiley & Sons, 1967.

[B71] Willhelm, R. and Waters, M., *Neutral Ground in High Voltage Transmission*. New York: Elsevier Publishing Co., 1956.

⁴An in-depth theoretical treatment of the basic coupling mechanism and electromagnetic propagation that may be applied to 60 Hz type problems.

[B72] Yu, L. Y. M., "Determination of Induced Currents and Voltages in Earth Wires During Faults." *Proceedings of the IEEE*, vol. 120, no. 6, June 1973.